



AURORA™ LED Gate Arm Light

Signal Products



In This Section:

Introduction

AURORA™ Complete Highway Crossing Signals

AURORA™ 8", 12", 5.5" LED's

PL100 Bayonet-Style Position Light LED

Highway Crossing Components

Mast Assemblies

AURORA™ Gate Arm Lights

Spectrom L Signals

Types AT and AW Color Light Signals

Type SA1 Searchlight Signal

Roundel and Phankill Assemblies

Introduction

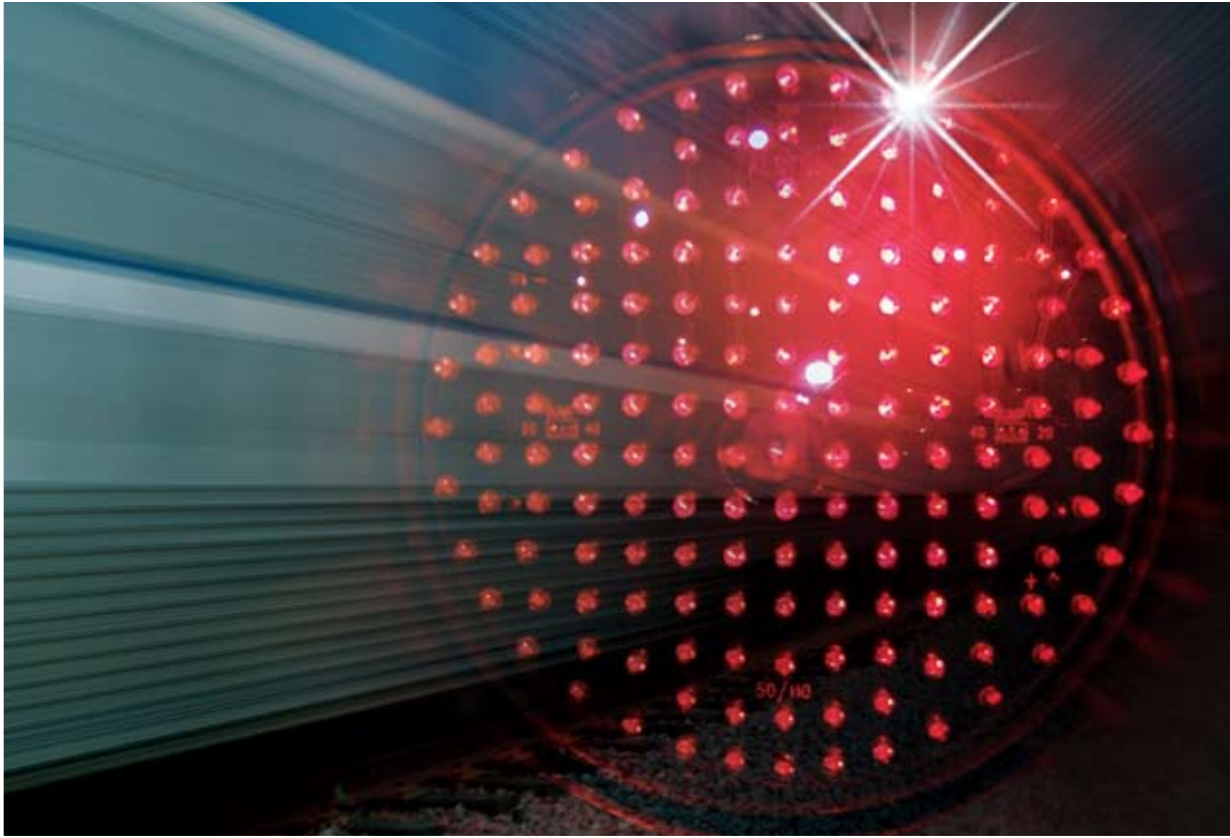

With more than 100 years of experience in signaling, Alstom provides signal solutions for mainline railroad and rapid transit wayside signals, interlockings, classification yards, and highway crossings. For the past century, Alstom has continually improved the safety and design of their signals.

The SA-1 Searchlight signals have proven to be the standard for reliability, flexibility, and fail-safe design. They are available in a high wayside signal or a 1 or 2 unit dwarf with a choice of either a compound or stepped lens system.

The AW and AT Color-Light signals are designed for use in transit installations and are available with incandescent lamps or LEDs. The latest enhanced design reduces spare parts requirements, simplifies access for maintenance, lowers cost of ownership, and increases safety.

The AURORA™ line of LED signals includes highway crossing flashing light units (8" and 12") as well as crossing gate arm flashing lights. The flashing light LED retrofit kits will replace old incandescent lights in just about any highway crossing installation. The AURORA gate arm kits come in a Quick Install version that takes just ten minutes to install.

AURORA™ Complete Highway 8" and 12" Crossing Signals

The **AURORA™ Highway Crossing Signal** uses rugged Light Emitting Diode (LED) technology as the light source instead of a conventional incandescent, filament bulb. The result is an extraordinarily reliable highway crossing signal with a life expectancy of up to 100,000 hours, which is twenty times greater than an incandescent bulb-based system.

The AURORA signal virtually eliminates phantom signals since it contains no reflector dish. Phankills are not required.

The AURORA Highway Crossing Signal is compatible with most AC and DC-based control systems for fast, economical installation. AURORA Retrofit Kits let you replace existing signals in the field. The kit contains everything you need to replace conventional bulb-based signals from:

- **GRS**
- **Western-Cullen-Hayes**
- **Premier Products**
- **Modern Industries (Harmon)**
- **Union Switch & Signal**
- **Safetran Systems**

AURORA Highway Crossing Signals are ideal for front-light, back-light or cantilever applications. The signal meets chromaticity requirements for red as recommended by AAR Manual Part 7.1.10, CIE PUB 2.2-1975 and ITE VCSH 8.04. It also complies with the Manual On Uniform Traffic Control Devices.

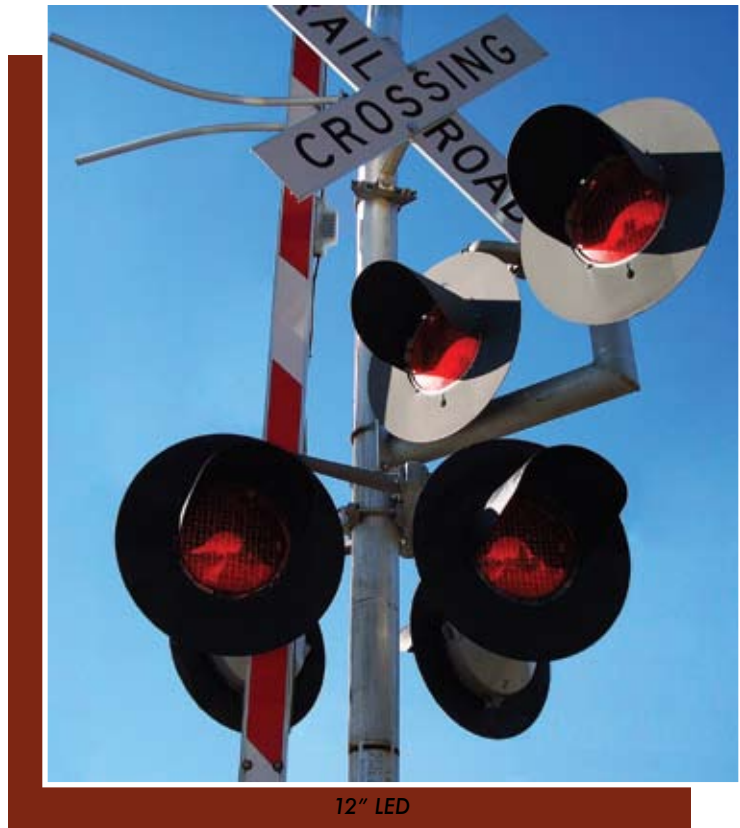

AURORA™ Complete Highway Crossing Signals with LED's

The new **Alstom Complete Highway Crossing Signals** are now available for purchase. The housings are aluminum and the backgrounds are powder coated, galvanized steel. Two or four unit housings are available in various configurations including 8" or 12" signal units with either LED or incandescent lights and 4" or 5" pole sizes.

These truly versatile Highway Crossing Signals will drastically simplify specifying, maintaining and operating your signals.

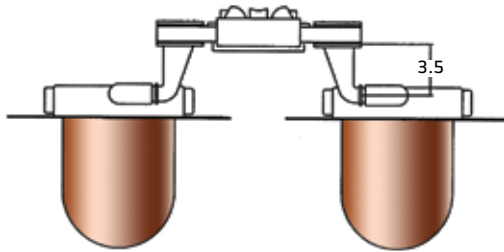

Figure 1

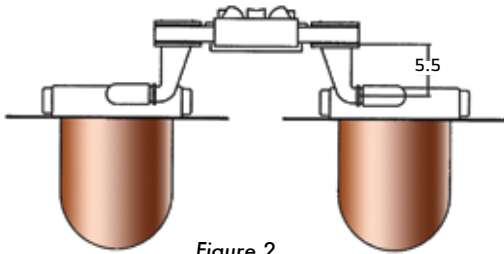

Figure 2

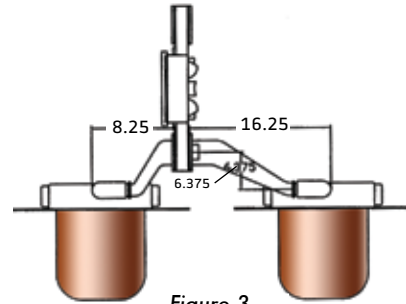

Figure 3

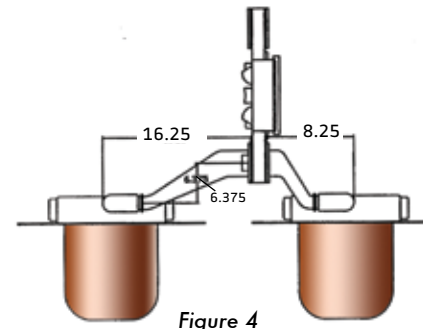

Figure 4

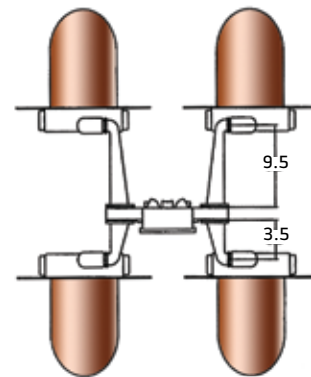

Figure 5

AURORA™ Complete Highway Crossing Signals with LED's

Specifications

Ordering Number	Reference	Signals	Signal Unit	Pole Size (inches)
55050-016-00	Figure 1	2 Signals	8 Inch with LED Module	4
55050-017-00	Figure 1	2 Signals	8 Inch with LED Module	5
55050-018-00	Figure 1	2 Signals	12 Inch with 160 LED Module	4
55050-019-00	Figure 1	2 Signals	12 Inch with 300 LED Module	4
55050-020-00	Figure 1	2 Signals	12 Inch with 160 LED Module	5
55050-021-00	Figure 1	2 Signals	12 Inch with 300 LED Module	5
55050-022-00	Figure 1	2 Signals	8 Inch with Incandescents	4
55050-023-00	Figure 1	2 Signals	8 Inch with Incandescents	5
55050-024-00	Figure 1	2 Signals	12 Inch with Incandescents	4
55050-025-00	Figure 1	2 Signals	12 Inch with Incandescents	5
55050-026-00	Figure 2	2 Signals	8 Inch with LED Module	4
55050-027-00	Figure 2	2 Signals	12 Inch with 160 LED Module	4
55050-028-00	Figure 2	2 Signals	12 Inch with 300 LED Module	4
55050-029-00	Figure 2	2 Signals	8 Inch with Incandescents	4
55050-030-00	Figure 2	2 Signals	12 Inch with Incandescents	4
55050-046-00	Figure 3	2 Signals	8 Inch with LED Module	5
55050-047-00	Figure 3	2 Signals	12 Inch with 160 LED Module	5
55050-048-00	Figure 3	2 Signals	12 Inch with 300 LED Module	5
55050-049-00	Figure 3	2 Signals	8 Inch with Incandescents	5
55050-050-00	Figure 3	2 Signals	12 Inch with Incandescents	5
55050-041-00	Figure 4	2 Signals	8 Inch with LED Module	5
55050-042-00	Figure 4	2 Signals	12 Inch with 160 LED Module	5
55050-043-00	Figure 4	2 Signals	12 Inch with 300 LED Module	5
55050-044-00	Figure 4	2 Signals	8 Inch with Incandescents	5
55050-045-00	Figure 4	2 Signals	12 Inch with Incandescents	5
55050-031-00	Figure 5	4 Signals	8 Inch with LED Module	4
55050-032-00	Figure 5	4 Signals	8 Inch with LED Module	5
55050-033-00	Figure 5	4 Signals	12 Inch with 160 LED Module	4
55050-034-00	Figure 5	4 Signals	12 Inch with 300 LED Module	4
55050-035-00	Figure 5	4 Signals	12 Inch with 160 LED Module	5
55050-036-00	Figure 5	4 Signals	12 Inch with 300 LED Module	5
55050-037-00	Figure 5	4 Signals	8 Inch with Incandescents	4
55050-038-00	Figure 5	4 Signals	8 Inch with Incandescents	5
55050-039-00	Figure 5	4 Signals	12 Inch with Incandescents	4
55050-040-00	Figure 5	4 Signals	12 Inch with Incandescents	5

For assistance in ordering any of these Complete Highway Crossing Signals, please contact the Alstom Customer Service Center at 1-800-717-4477.

AURORA™ 8" and 12" LED Retrofit Highway Crossing Signal



AURORA 12" LED Highway Crossing Retrofit

FEATURES

12" AURORA 300 and 160

- **Brightest signal available in the market – 1600 cd on axis (300)**
- **Low cost – high intensity – 830 cd on axis (160)**
- **Independent bright white LED side lights for best viewing**
- **Regulated power supply – LED unit emits constant light output even at low voltages**
- **Red high impact UV stabilized outer lens**
- **No focusing required**
- **Compatible with all standard highway crossing signal housings**
- **Voltage turnoff at 7.5 volts**
- **No phankill required**

The **AURORA 12" LED** lamp unit measures 12" in diameter. It is a self contained unit; the lens and individual LEDs are not replaceable. The 12" LED unit is sealed and includes a high impact, UV stabilized, outer lens and separate white sidelights. A regulated power supply maintains constant light output during supply voltage variation.

The 12" LED units are available in a retrofit kit for installation in any standard highway crossing signal housing. These units are also available as a complete signal head with an aluminum housing, 20" background, and hood.

Ordering Information

Product Name	Description	Ordering Number	Price
AURORA 12" 160	12-inch AURORA Highway Crossing Signal Retrofit Kit	59649-200-02	\$ 200.00
AURORA 12" 300	Ultra Bright 12-inch AURORA Highway Crossing Signal Retrofit Kit	59649-200-03	\$ 289.00
AURORA 12" 160	12-inch AURORA Highway Crossing Signal Complete with Housing, 20-inch Dia. Background and Hood	59649-200-04	\$ 569.00
AURORA 12" 300	Ultra Bright 12-inch AURORA Highway Crossing Signal Complete with Housing, 20-inch Dia. Background and Hood	59649-200-05	\$ 895.00
AURORA 8"	8-inch AURORA Highway Crossing Signal Retrofit Kit	59649-202-02	\$ 199.00

AURORA™ 8" and 12" LED Retrofit Highway Crossing Signal

FEATURES

8" AURORA 160

- Has 160 LEDs (850 candela intensity on axis)
- Is designed to be a direct replacement for incandescent bulbs, LED boards, or LED modules that fit inside an 8 3/8 inch railway crossing signal
- Contains two side-lights, one on each side of the signal, each containing 12 white LEDs
- Is compatible with standard "8 inch" signal housings



AURORA 12" LED Highway Crossing Retrofit

Performance Standards

Parameter	Standard
Environmental Requirements	• AREMA Standard Class B • MIL-STD 810
Operating Temperature	-40°C to 70°C
IP Rating	IP65
Electronic Noise	Meets AREMA Standard
Storage Temperature	-55°C to 85°C
Photometric Requirements	Transport Canada Standard

The **AURORA 8" LED** light source, or LED lamp unit, measures 8.375" in diameter. It is a self contained unit; the lens and individual LEDs are not replaceable. The 8" LED lamp unit is a sealed unit that includes a high impact, UV stabilized, outer lens and separate white sidelights. A regulated power supply maintains constant light output during supply voltage variation. The unit contains two side-lights, one on each side of the signal. The front LEDs are red and the side-light LEDs are white.

Specifications

Data	AURORA 160 (8.375 inch)	AURORA 160 (12 inch)	AURORA 300 (12 inch)
Operating Voltage	8 to 20 VDC or 8 to 16 VAC	8 to 20 VDC or 8 to 16 VAC	8 to 20 VDC or 8 to 16 VAC
Current (Nominal)	1.0 Amps at 10 VDC 1.1 Amps at 10 VAC	1.0 Amps at 10 VDC 1.1 Amps at 10 VAC	1.2 Amps at 10 VDC 1.3 Amps at 10 VAC
Typical Power Consumption	10 Watts at 10 VDC 11 Watts at 10 VAC	10 Watts at 10 VDC 11 Watts at 10 VAC	12 Watts at 10 VDC 13 Watts at 10 VAC
Dominant Wavelength	630 NM	630 NM	630 NM
Peak Intensity	850 Candela	850 Candela	1600 Candela
Temp. Range			
Operating	-40° C to + 70° C	-40° C to + 70° C	-40° C to + 70° C
Storage	-55° C to + 85° C	-55° C to + 85° C	-55° C to + 85° C

AURORA™ LED PL100

Bayonet-Style Position Light LED

FEATURES

- State-of-the-art High Intensity Surface Mount LEDs with Integrated Lens
- Robust, Heavy Duty Packaging
- Compatible with Standard Bayonet Lamp Sockets
- Designed with LEDs to be at same dimensional position as bulb filament in typical assemblies
- Long Life LED Technology Reduced Maintenance Costs from Lamp Burn-outs
- Available in Lunar White

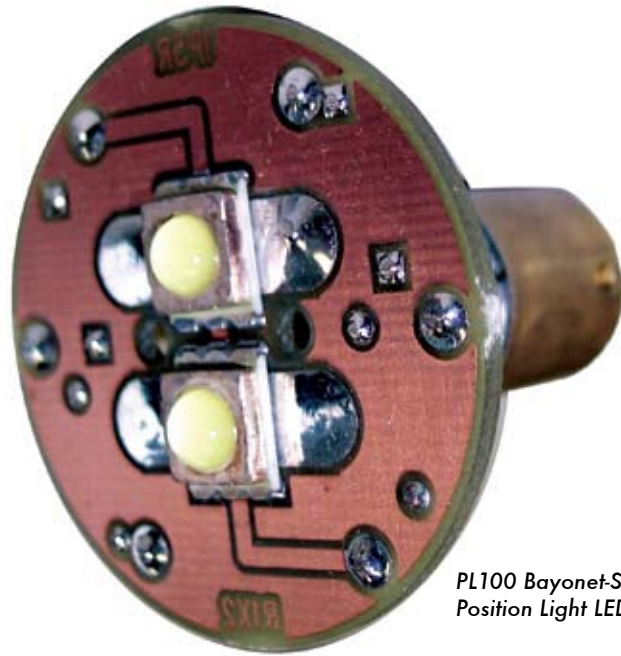

PL100 Bayonet-Style Position Light LED

Note: Indicators Only - Not Vital Signals

Specifications

Data	Value
Operating Voltage Range	8.5V to 12.0 VDC or AC
Nominal Current Drawn (at 10V DC)	0.3A
Typical Power Consumption	3W at 10VDC
Minimum Luminous Flux (lumens at 10V DC)	100 Lm
Environmental Requirements	AREMA Standard Class B • MIL-STD 810F
Operating Temperature Range	- 40°C to 70°C

Ordering Information

Product Name	Description	Ordering Number	Price
PL100 Bayonet-Style Position Light LED	(Lunar White)	47437-034-00	\$ 89.00

AURORA™ Complete Highway Crossing Additional Components

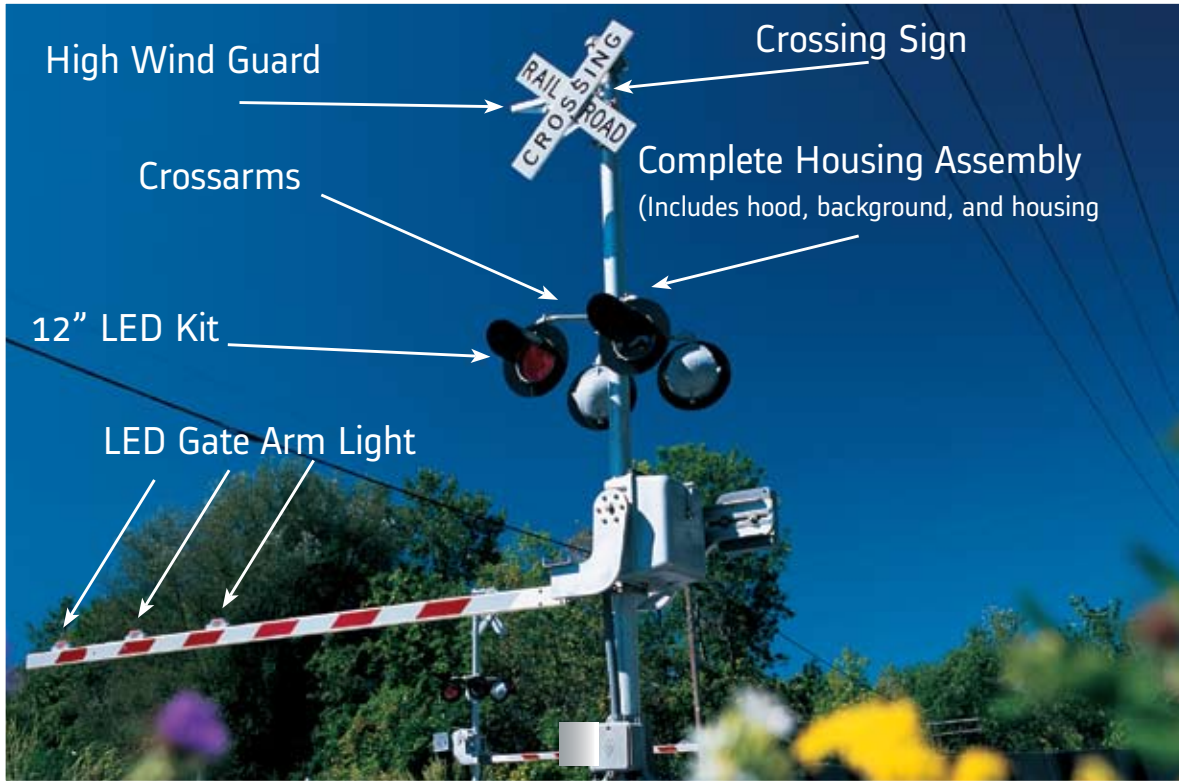

AURORA Highway Crossing Components

Also available from Alstom are additional highway crossing components other than the AURORA LED flashing light retrofit kits and AURORA LED gate arm kits:

- **High Wind Guard**
Protects the gate arm from possible damage due to strong winds
- **Crossing Sign**
"RAILROAD CROSSING" crossbuck sign
- **Flashing Light Housing Assembly**
Complete 12" flashing light housing with background and hood. Does not include the LED light kit
- **Flashing Light Unit Crossarms**
For two light units or four light units

Ordering Information

Description	Ordering Number	Price
High Wind Guard	55329-006-00	\$ 149.00
12" LED Kit	59649-200-02	\$ 200.00
LED Gate Arm Light - Premium GAL 200	59649-201-03	\$ 379.00
LED Gate Arm Light - Standard GAL 100	59649-201-01	\$ 259.00
Complete Housing Assembly 12" (Includes: Case, terminal block, 20" dia. background, and hood.) Does Not Include LED Light Kit	55051-013-00	\$ 995.00

Mast Assemblies



Typical Mast Assemblies

Mast assemblies are available in any height required and can come complete with ladders, ladder foundation, platforms, pinnacle, and junction box or split base.

They can be drilled for one, two or three signal heads. Please contact Alstom with your specific requirements.

Ordering Information - Mast Assemblies

Drilled For Signal Heads	Base Type	Ordering Number	Price
2	Split	73001-124-01	Call for price
2	Split Junction Box	73001-125-01	Call for price
2	Split	73001-126-01	Call for price
2	Split Junction Box	73001-024-01	\$ 3,995.00
3	Split	73001-128-01	Call for price
3	Split Junction Box	73001-129-01	Call for price

Ordering Information - Foundation

Description	Ordering Number	Price
SPLIT BASE COMPLETE, for 5" mast	43951-017-01	\$ 1,299.00
JUNCTION BOX BASE COMPLETE, with 24 terminal posts, for 5" mast	43951-016-06	\$ 2,895.00
FOUNDATION, for ladder, includes bolts and nuts	36773-000-01	Call for price
PINNACLE, for 5" diameter mast	56894-000-08	\$ 162.00

AURORA™ LED Gate Arm Light



AURORA LED Gate Arm Light

The **AURORA™ Gate Arm Light** is a cost-effective solution to expensive, incandescent type gate arm lights. The AURORA Gate Arm Light uses rugged Light Emitting Diode (LED) technology instead of a fragile filament bulb for illumination. Each AURORA light has four wires for the electrical connection. Like the AURORA Highway Crossing Signal, it offers customers an extraordinary life expectancy of up to 100,000 hours.

The AURORA Gate Arm Light uses less than 20% of the power required by a conventional incandescent bulb-based system. It is housed in an impact resistant plastic housing. The lights are designed to hold up to “knockdowns”.

FEATURES

AURORA Premium GAL 200

- **Quick Install - Complete installation in only ten minutes with one tool**
- **Complete kit with “PLUG-IN” connectors and coil cords**
- **Brightest LED gate arm light available in the market (Each unit contains 36 Ultra Bright or Super Bright LED’s)**
- **LED viewing angle of 30 degrees (Most LED’s in the market have 15 degree viewing)**
- **Exceeds the AREMA recommended 70 degree beam spread**
- **Tested for over 200,000 operations without a single LED failure**
- **Can be used with highway crossing systems of any make and model**

AURORA Standard GAL 100

- **Most cost-efficient LED gate arm light available in the market**
- **Brightest LED gate arm light available in the market (Each unit contains 36 Ultra Bright LED’s)**
- **LED viewing angle of 30 degrees (Most LED’s in the market have 15 degree viewing)**
- **Exceeds the AREMA recommended 70 degree beam spread**
- **Tested for over 200,000 operations without a single LED failure**
- **Can be used with highway crossing systems of any make and model**

AURORA™ LED Gate Arm Light

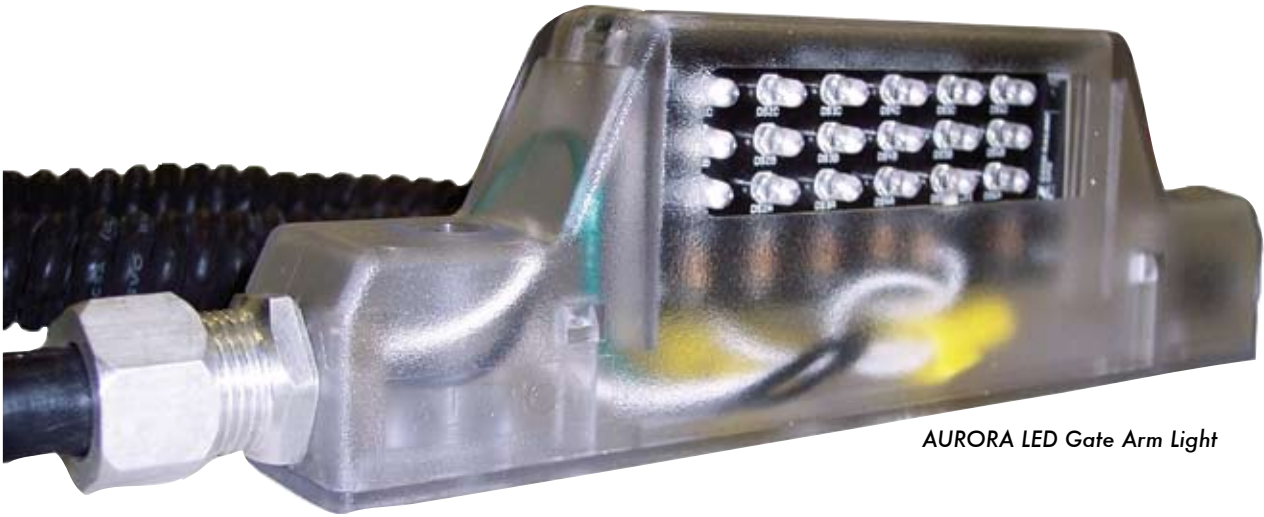

AURORA LED Gate Arm Light

Specifications

Data	Value
Operating Voltage	8.5 V AC/DC – 12 V AC/DC
Minimum Forward Current	10 mA
Recommended Operating Voltage	10 VDC
Typical Max. Forward Current Draw(at 10 VDC)	0.35 Amps
Typical Max. Power Consumption (at 10 VDC per gate light)	3.5 Watts

Performance Standards

Parameter	Range
Vibration (X, Y and Z axis)	<ul style="list-style-type: none"> · AREMA Standard Class B · MIL-STD 810F
Operating Temperature	-40°C to 70°C
P Rating	IP65
Electronic Noise	Meets AREMA Standards
Storage Temperature	-40°C to 85°C

Ordering Information

Product Name	Description	Ordering Number	Price
AURORA Standard GAL 100	Set of three Ultra Bright Gate Arm Lights with installation hardware	59649-201-01	\$ 259.00
AURORA Premium GAL 200 Quick Install	Set of three Ultra Bright Gate Arm lights with quick connect coil cords and hardware	59649-201-03	\$ 395.00

Spectrom L Switch Position Indicator



Switch Position Indicator

The **Spectrom L Switch Position Indicator** is comprised of a 4 aspect housing with configurable lamp arrangements. Typically a green aspect is displayed to indicate that the switch machine is lying in the normal position and yellow indicates reverse.

FEATURES

- Functions as a multi-purpose signal, route indicator or switch position indicator with normal or bi-directional aspects
- Uses Industry Standard 5" LED Modules
- Engineered Plastic Housing
- Pole Mounted
- Modular Design
- Side Access to Terminations
- Easy change out LED Modules

LEXAN™ FEATURES

- Highest Flammability Rating (UL94-5VA)
- Excellent UV Protection (UL94 f1 rated)
- Superior impact properties (ductile from -50° and above)
- Low smoke properties (meets ASTM E662)
- ECO conforming (no bromine, chlorine or other halogens)

The signal is easily configurable and blanking plates are used to cover unused positions when necessary. The Switch Position indicator is pole mounted with accessible terminations through the secure side panel.

Ordering Information

For assistance in ordering and specification of the Switch Position Indicator please contact the Alstom Customer Service Center at 800-717-4477.

Note: Units may be purchased with any of 5½" retrofit lamp LED's listed on page 13 of this section. Lexan™ is a trademark of the General Electric Company.

SPECTROM LT

Signals for Transit

FEATURES

- **LEXAN™ - Breakthrough Technology in Plastic Housings allow for efficient applications in ANY environment**
- **Low Power Consumption and Long Life LED's**
- **Superior impact properties - ductile from -50 degrees C and above**
- **Versatile Mounting and Positioning; 3 to 10 Lamp Positions**
- **Convenient Side Access to Terminations**
- **Ideal for Narrow Tunnel Applications**
- **Easy change out led modules**

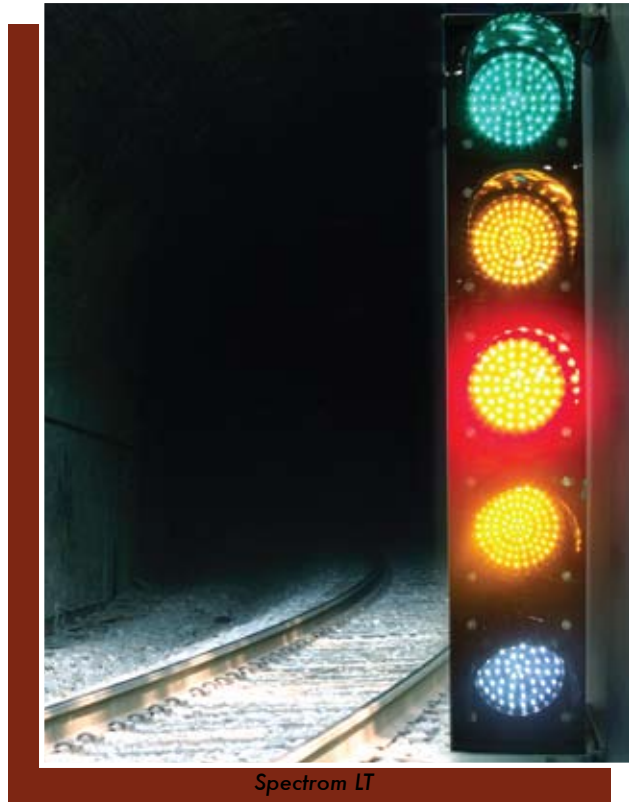

Spectrom LT

The **Spectrom L** line of housings for switch-position indicators and transit/railroad signals are designed to withstand the harshest environmental conditions. Manufactured from Lexan™, a tough, long-life polycarbonate-siloxane copolymer sheet and resin, the housings are corrosion and U.V. resistant, non-conductive, and are designed to withstand flying debris from tracks.

Housings for switch-position indicators can be pole mounted, while those for transit signals can be pole-, ground-, or wall-mounted. Spectrom L railroad signal housings, which are available in standard sizes and shapes in many configurations, are able to adapt to industry standard mounting hardware. Five-inch and eight-inch LED modules are used in transit and freight applications, respectively.

Specifications

Data	Value
Operating Temperature	-50° C and above
Weight	15 lbs. (3 aspect)
Dimensions	28" h x 14" d x 6" w (3 aspect)

Ordering Information

For assistance in ordering and specification of the ALSTOM Spectrom L, please contact the Alstom Customer Service Center at 800-717-4477.

Note: Units may be purchased with any of 5½" retrofit lamp LED's listed in our signal section on page. Lexan™ is a trademark of the General Electric Company.

Type AT Color - Light Signals



Type AT Color Light Signal

FEATURES

- **Narrowest cast aluminum signal on the market**
- **Ideal for places with minimal clearance**
- **Available in both LED and incandescent types**
- **Available in pole, wall, hat and horizontal mounted configurations**
- **Easy access to the transformer terminal block and the wiring from the back of the signal**
- **All external protruding bolt threads have been eliminated to safeguard workers from cuts and injuries**

The **Type AT Color-Light Signal** is a compact unit designed for rapid transit lines where clearances are very limited. The Type AT Signal, ideal for underground (tunnel) installation, is equipped with a single optical lens since the efficiency of a doublet lens is not required in a dark environment. The 5" (12.7 cm) lens has a 3.5" (8.9 cm) focal length.

The lens may be specified in red, yellow, green, lunar white or clear. The modular design of the Type AT Signal permits multiple units to be bolted together, one atop the other, for the desired signal configuration. These signals are typically supplied with mounting brackets for subway walls or ceilings. When space is limited, the AT is the perfect solution.

Specifications

Data	AT Signal
Height	28.75" (73.03 cm)
Width	9.06" (23.01 cm)
Depth	6.13" (15.57 cm)
Aspect to Aspect Distance	5.75" (14.61 cm)
Diameter of Outer Lens	5" (12.70 cm) Dia.
Case Material	Aluminum
Bulb Operating Voltage	8-13 Volts
Bulb Wattage	5 Watts
Transformer Specification	120/10 V Step Down

Ordering Information

The Type AW and Type AT Color-Light Transit Signals are available in many different arrangements of subassemblies and aspects with numerous options. Please contact the Alstom Customer Service Center at 1-800-717-4477 for assistance in ordering a signal for your specific application. Vandal Guards and Hoods are optional.

Type AW Color - Light Signals

FEATURES

- All repairs from back of the signal, Including replacement of the outer lens
- Available in LED and incandescent applications
- Ideal for tunnel and wayside applications
- Simplified receptacle and door hasp design
- Integrated door hinges reduce the time that's required to remove or assemble the door by nearly 75%
- Reduces spare part inventory by up to 40%
- Available in pole, wall, hat and horizontal mounted configurations
- All external protruding bolt threads have been eliminated to safeguard workers from cuts and injuries
- Available with track indicator unit. Displays numeral 00-99 programable with input RS 232

The **Type AW Color-Light Signal** is a compact signal designed for outdoor applications on rapid transit lines. The LED signal uses a single clear roundal with a LED module behind the roundal inside the case. The incandescent signal uses a doublet lens combination. The 6.375" (16.2 cm) clear outer lens has a 3.75" (9.53 cm) focal length. The 5.50" (13.97 cm) inner lens maybe ordered in red, yellow, green, lunar white or clear. The modular design of the Type AW Signals permits multiple units to be bolted together, one atop the other, for the desired signal configuration. Enhanced design reduces spare part requirements, simplifies maintenance and lowers cost of ownership by up to 35% while delivering safe, reliable service. The AW's flexibility makes it ideal for both wayside and tunnel installations.

Specifications

Data	AW Signal
Height	39.75" (100.97 cm)
Width	12.75" (32.39 cm)
Depth	8.736" (22.19 cm))
Aspect to Aspect Distance	9.75" (24.27 cm)
Diameter of Outer Lens	6.38" (16.21 cm) Dia.
Case Material	Aluminum
Bulb Operating Voltage	8-13 Volts
Bulb Wattage	18 Watts and 25 Watts
Transformer Specification	120/10 V Step Down

Ordering Information

The Type AW and Type AT Color-Light Transit Signals are available in many different arrangements of subassemblies and aspects with numerous options. Please contact the Alstom Customer Service Center at 1-800-717-4477 for assistance in ordering a signal for your specific application. Vandal Guards and Hoods are optional.



Type AW Signal

Type SA-1 searchlight Signal



Type SA-1 Searchlight Signal

FEATURES

- Aspect-checking contacts directly operated by counterweights
- Slanted color discs minimize beam dilution
- Choice of compound or stepped lens system
- Available with 20-degree deflecting roundel or 30-degree Spredlite roundel
- Wide choice of assemblies and wire entrance couplings
- Precision filament lamp needs no refocusing when changing
- Built-in sighting fixture
- Built-in surge arrestor
- Plug-in, cartridge-type, adjustable lamp resistor
- Optional phankill unit reduces beam dilution

Call Our Customer
Service Center
to Order

1-800-717-4477

Type SA-1 Searchlight Signal

The Type SA-1 Searchlight Signal features an efficient electro-magnetic structure, maximum back contact pressure, positive contact closure and precise color-disc positioning. This signal operates from battery or rectified AC-energy (8-12VDC).

The Type SA-1 Signal consists of a compact operating mechanism and a durable cast aluminum housing. The housing may be bracket mounted to the side or front of the signal mast, provided with a socket for mounting to the top of the mast or provided with a base mounting for a concrete foundation.



Type SA-1 Lamp Receptacle with Reflective Background

The Type SA-1 Signal projects three aspects through a single optical system: red, yellow and green. This system supplies a powerful light beam using minimal energy. The signal has been designed to be fail-safe; if power is interrupted, it automatically displays the most restrictive aspect.

The signal housing includes an 8.375" (21.3 cm) diameter lens, hood, ventilators, background, mounting bracket, base, or mounting socket. The unit's operating mechanism slides easily into place using a hanger and track system. Cams and locking pins ensure the mechanism remains in a secure, locked position.

All Type SA-1 Searchlight Signals are available with either a compound or stepped lens. The compound lens produces a longer-range light beam without the need for additional power. Outer roundels are available to spread or deflect the light beam for installations where the track curves. A phankill can also be supplied to minimize light beam dilution and prevent phantom signals caused by sunlight. Type SA-1 Mast-Mounted High Signals are available with either an operative or inoperative mechanism. Optional mast assemblies are available complete with pinnacle, base, ladder, ladder foundation and platform.

Type SA-1 Dwarf Signals use one or two mechanisms. Optional equipment includes roundel and phankill assemblies, wire entrance couplings, conduit and adjustable lamp resistors.

Specifications

Value	Data
Overall length of signal, including hood	Compound lens system: 34" (86.36cm) Stepped lens system: 29-3/4" (75.57 cm)
Overall height of signal (either lens system)	27-7/8" (70.80 cm)
Lens bezel ring, overall diameter:	10" (25.40 cm)
Weight of Signal housing and signal mechanism	Stepped lens system: 140 lbs. (63.56 kg) Compound lens system: 160 lbs. (72.74 kg) Signal mechanism only: 25 lbs. (11.35 kg)

Type SA-1 Searchlight Signal

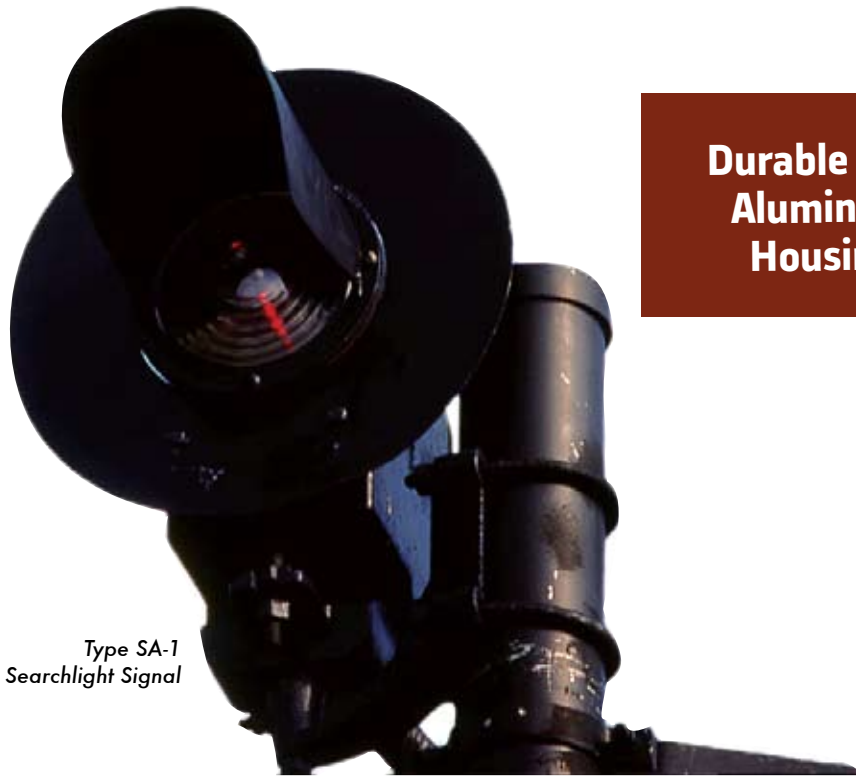

Type SA-1
Searchlight Signal

**Durable Cast
Aluminum
Housing**

1-800-717-4477

Ordering Information - Type SA-1 Signal, High Signal Heads, with Mechanism

Type of Mechanism	Lens System	Aspect Color	Type of Wire Connection	Ordering Number	Price
Operating	Compound	GRY	Plug Coupler	A76-0114	\$ 11,995.00
Inoperative	Compound	R	AAR Terminals	A76-0115	\$ 6,995.00
Operating	Stepped	GRY	Plug Coupler	A76-0118	\$ 11,995.00
Inoperative	Stepped	R	AAR Terminals	A76-0119	Call for price

Note 1: Type SA-1 Signals listed include signal housing with operating mechanism, hood, 35" diameter background, 8.375" diameter outer lens for tangent track, ventilators, and bracket for side-mounting on a 5" diameter mast.

Note 2: The following are NOT INCLUDED, please order separately: wire entrance coupling, lamp resistor, roundel, phankill assembly, top or front mounting bracket, optional 20" diameter background.

Ordering Information - Type SA-1 Signal, High Signal Heads, without Mechanism

Type of Mechanism	Lens System	Aspect Color	Type of Wire Connection	Ordering Number	Price
(None)	Compound	(None)	(None)	A76-0136	\$ 3,500.00
(None)	Stepped	(None)	(None)	A76-0138	\$ 3,500.00

Note 1: A signal housing, less mechanism, includes a hood, 35" diameter background, 8.375" diameter outer lens for tangent track, ventilators, and brackets for side-mounting on a 5" diameter mast.

Note 2: A signal housing DOES NOT INCLUDE a wire entrance coupling. Please order separately.

Type SA-1 Searchlight Signal Parts and Accessories



Type SA-1 DwarfSignal

Ordering Information - Type SA-1 Signal, Dwarf Signal Heads with Mechanism

Reference	Units	Type of Mechanism	Lens System	Aspect Color	Type of Wire Connection	Ordering Number	Price
A	1	Operating	Compound	GRY	Plug Coupler	A76-0201	\$ 11,995.00
A1	1	Inoperative	Compound	R	AAR Terminals	A76-0202	\$ 5,999.00
B	1	Operating	Stepped	GRY	Plug Coupler	A76-0206	\$ 10,995.00
B1	1	Inoperative	Stepped	R	AAR Terminals	A76-0207	Call for price
C	2	Operating	Compound	GRY	Plug Coupler	A76-0211	\$ 22,995.00
C1	2	Inoperative	Compound	R	AAR Terminals	A76-0212	Call for price
D	2	Operating	Stepped	GRY	Plug Coupler	A76-0216	\$ 20,995.00

Note : The dwarf signal includes the housing with operating or inoperative mechanism, hood, background, 8.375" diameter V-inclined 10° upward deflecting roundel, ventilators, and base.

Note: The dwarf signal does NOT INCLUDE wire entrance coupling, lamp resistor, or Phankill assembly. Please order separately.

Ordering Information - Type SA-1 Signal, Dwarf Signal Heads without Mechanism

Type of Mechanism	Lens System	Aspect Color	Number of Units	Ordering Number	Price
—	Compound	—	1	A76-0220	\$ 3,500.00
—	Stepped	—	1	A76-0221	\$ 2,995.00
—	Compound	—	2	A76-0225	\$ 5,995.00
—	Stepped	—	2	A76-0226	\$ 5,195.00

Note : The dwarf signal includes the hood.

Type SA-1 searchlight Signal Parts and Accessories

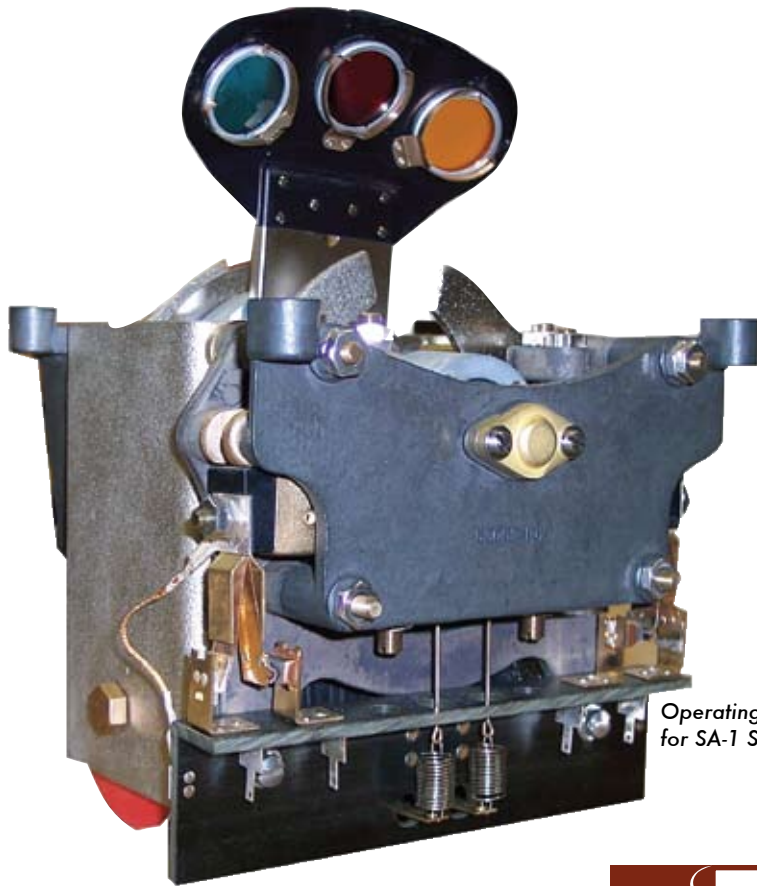

Operating Mechanism for SA-1 Signal

The **operating mechanism** may be supplied with a compound or stepped lens system. These mechanisms come with a plug coupler for wire connections. The operating mechanism does NOT INCLUDE a lamp or the lamp resistor.

The **inoperative mechanism** is available with a compound or stepped lens system. This mechanism is supplied with standard AAR terminal posts for wire connections. The inoperative mechanism does NOT INCLUDE a lamp or the lamp resistor.



VISIT
www.alstomsignalingolutions.com
 for all your signaling needs!

Ordering Information - Operating Mechanism

Lens System	Aspect Color	Ordering Number	Price
Compound	G R Y	59545-150-03	\$ 8,995.00
Stepped	G R Y	59545-100-02	\$ 8,995.00

Ordering Information - Inoperative Mechanism

Lens System	Aspect Color	Ordering Number	Price
Compound	Red	53052-339-05	\$ 3,599.00
Stepped	Red	53052-387-01	\$ 3,595.00

Roundel and Phankill Assemblies

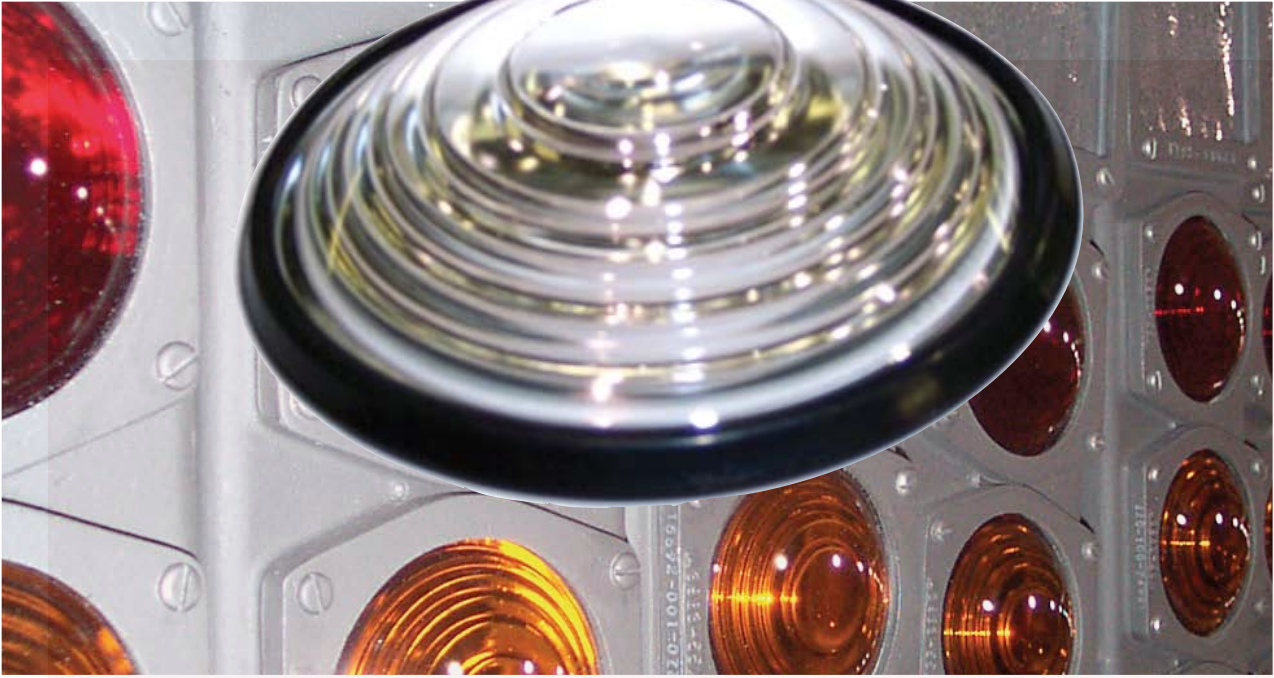

Roundel Assembly

Signal heads furnished with 8.375" (21.27 cm) diameter lenses for tangent track only may be easily adapted for special conditions by adding a roundel or phankill assembly. The phankill eliminates spread. This special optical equipment comes ready-to-install except for sealing compound which must be ordered separately. ALSTOM recommends soft mastic sealing compound per ALSTOM specification 90B0010, available in a one pound plug of material.

Roundel assemblies fit both stepped and compound lens signals. Phankill assemblies for high signals have a built-in 25° close-up roundel. On compound lens high signals, remove the existing close-up roundel before installing the phankill. A phankill used with a stepped lens requires a separate order for a signal head with clear center lens, which is specially arranged for use with a phankill.

Ordering Information

Description	Ordering Number	Price
ROUNDEL ASSEMBLY, inclined 20-degree deflecting, for compound or stepped lens high signals	A76-0350	\$ 795.00
ROUNDEL ASSEMBLY, 30-degree Spredlite, for compound or stepped lens high signals	A76-0353	\$ 1,563.00
PHANKILL ASSEMBLY, for compound or stepped lens high signal. The inclined roundel is 30-degree Spredlite type	A76-0363	\$ 1,595.00
PHANKILL ASSEMBLY, for compound or stepped lens dwarf signal	A76-0370	\$ 795.00
PHANKILL UNIT, with 25-degree close-up prism, for high signals	56629-007-00	\$ 787.00
PHANKILL COMP., for dwarf signals	56629-006-01	\$ 313.00