

ALSTOM

Model 7R Switch Circuit Controller

Copyright © 2010, 2011 Alstom Signaling Inc.



Operation and Maintenance Manual
P2527

ALSTOM

Model 7R Switch Circuit Controller

Copyright © 2010, 2011 Alstom Signaling Inc.



Operation and Maintenance Manual
Alstom Signaling Inc.

P2527, Rev. 3, June 2011 Printed in U.S.A.

LIST OF EFFECTIVE PAGES

P2527, Model 7R Circuit Controller Operation and Maintenance Manual

ORIGINAL ISSUE DATE: November 2010

CURRENT REVISION AND DATE: June 2011 Updated Table 3–3, Steps 7–10, page 3–8, explaining how to adjust length of the J-rod.

PAGE	CHANGE OR REVISION LEVEL
Cover	June /11
Title page	June /11
Preface	June /11
i thru iv	June /11
1–1 thru 1–8	June /11
2–1 thru 2–4	June /11
3–1 thru 3–16	June /11
4–1 thru 4–8	June /11
5–1 thru 5–2	June /11
6–1 thru 6–6	June /11
7–1 thru 7–10	June /11
A–1 thru A–12	June /11

THIS PAGE INTENTIONALLY LEFT BLANK.

PREFACE

NOTICE OF CONFIDENTIAL INFORMATION

Information contained herein is confidential and is the property of Alstom Signaling Incorporated. Where furnished with a proposal, the recipient shall use it solely to evaluate the proposal. Where furnished to customer, it shall be used solely for the purposes of inspection, installation or maintenance. Where furnished to a supplier, it shall be used solely in the performance of the contract. The information shall not be used or disclosed by the recipient for any other purposes whatsoever.

**FOR QUESTIONS AND INQUIRIES, CONTACT CUSTOMER SERVICE AT
1-800-717-4477
OR
WWW.ALSTOMSIGNALINGSOLUTIONS.COM**

**ALSTOM SIGNALING INC.
1025 JOHN STREET
WEST HENRIETTA, NY 14586**

REVISION LOG

Revision	Date	Description	By	Checked	Approved
1	November 2010	Original issue.	MAS	RR	NI
2	February 2011	Added note and warning to pages 3-1 and 7-2 explaining as shipped wiring.	MAS	RR	NI
3	June 2011	Updated Table 3-3, Steps 7-10, page 3-8, explaining how to adjust length of the J-rod.	JF	RR	NI

THIS PAGE INTENTIONALLY LEFT BLANK.

ABOUT THE MANUAL

This manual is intended to provide the necessary information to maintain and ensure proper operation of the Model 7R Switch Circuit Controller.

The information in this manual is arranged into sections. The title and a brief description of each section follow:

Section 1 – GENERAL DESCRIPTION: This section provides general information on the components of the Model 7R Switch Circuit Controller.

Section 2 – THEORY OF OPERATION: This section provides general information on the operation of the Model 7R Switch Circuit Controller. Safety precautions are also provided in this section.

Section 3 – INSTALLATION: This section describes the installation and adjustment of the Model 7R Switch Circuit Controller.

Section 4 – PREVENTIVE MAINTENANCE: This section describes the preventive maintenance procedures performed on the Model 7R Switch Circuit Controller.

Section 5 – TROUBLESHOOTING: This section describes possible failures/symptoms along with the corrective action for the Model 7R Switch Circuit Controller.

Section 6 – CORRECTIVE MAINTENANCE: This section describes the testing and adjustment procedures associated with corrective maintenance of the Model 7R Switch Circuit Controller.

Section 7 – PARTS CATALOG: This section identifies and lists the spare parts associated with the Model 7R Switch Circuit Controller.

Appendix A – CIRCUIT DRAWINGS: This section provides examples of wiring details for the Model 7R Switch Circuit Controller.

THIS PAGE INTENTIONALLY LEFT BLANK.

MANUAL SPECIAL NOTATIONS

In the Alstom manuals, there are three methods used to convey special informational notations to the reader. These notations are warnings, cautions, and notes. Both warnings and cautions are readily noticeable by boldface type two lines beneath the caption.

Warning

A warning is the most important notation to heed. A warning is used to tell the reader that special attention needs to be paid to the message because if the instructions or advice is not followed when working on the equipment then the result could be either serious harm or death. The sudden, unexpected operation of a switch machine, for example, or the technician contacting the third rail could lead to personal injury or death. An example of a typical warning notice follows:

WARNING

DISCONNECT THE MOTOR ENERGY WHENEVER THE GEAR COVER IS REMOVED. OTHERWISE, THE SWITCH MACHINE MAY OPERATE UNEXPECTEDLY AND POSSIBLY CAUSE PERSONAL INJURY.

Caution

A caution statement is used when an operating or maintenance procedure, practice, condition, or statement, which if not strictly adhered to, could result in damage to or destruction of equipment. A caution statement is also used when personnel could be surprised if shocked by a circuit operating at a low current. A typical caution found in a manual is as follows:

CAUTION

Turn power off before attempting to remove or insert circuit boards into a module. Boards can be damaged if power is not turned off.

Note

A note is normally used to provide minor additional information to the reader to explain the reason for a given step in a test procedure or to just provide a background detail. An example of the use of a note follows:

NOTE

A capacitor may be mounted on the circuit board with a RTV adhesive. Use the same color RTV.

THIS PAGE INTENTIONALLY LEFT BLANK.

TABLE OF CONTENTS

Topic	Page
1. SECTION 1 – GENERAL DESCRIPTION	1-1
1.1. SCOPE OF MANUAL	1-1
1.2. GENERAL	1-1
1.3. FEATURES	1-2
1.4. FUNCTION	1-4
1.5. HARDWARE DESCRIPTION	1-5
2. SECTION 2 – THEORY OF OPERATION	2-1
2.1. GENERAL	2-1
2.2. OPERATION	2-1
2.2.1. Model 7R Operation	2-1
2.2.2. Centering Attachment.....	2-3
3. SECTION 3 – INSTALLATION.....	3-1
3.1. GENERAL	3-1
3.2. APPLICATIONS	3-1
3.3. EXAMPLE WIRING DIAGRAMS	3-1
3.4. REQUIRED INSTALLATION EQUIPMENT	3-2
3.5. INSTALLATION PROCEDURE	3-3
3.6. FIELD INDICATION ADJUSTMENT.....	3-11
4. SECTION 4 – SCHEDULED MAINTENANCE	4-1
4.1. GENERAL	4-1
4.2. REQUIRED TEST EQUIPMENT	4-1
4.3. PREVENTIVE MAINTENANCE INDEX.....	4-2
4.4. LUBRICATION	4-3
4.5. VERIFICATION	4-5
4.6. CENTERING ATTACHMENT CHECK.....	4-8
5. SECTION 5 – TROUBLESHOOTING.....	5-1
5.1. GENERAL PHILOSOPHY	5-1
5.2. TROUBLESHOOTING	5-1
6. SECTION 6 – CORRECTIVE MAINTENANCE	6-1
6.1. GENERAL PURPOSE	6-1
6.2. REQUIRED TEST EQUIPMENT	6-1
6.3. REMOVAL AND REPLACEMENT PROCEDURES.....	6-2
6.3.1. Limit Switch Removal and Replacement	6-3
6.4. OBSTRUCTION TEST	6-6

TABLE OF CONTENTS (CONT.)

Topic	Page
7. SECTION 7 – PARTS CATALOG	7-1
7.1. GENERAL	7-1
7.2. PARTS LISTS AND DRAWINGS	7-1
7.2.1. Model 7R Switch Circuit Controller	7-2
7.2.2. Model 7R Switch Circuit Controller Centering Attachment	7-8
7.2.3. Model 7R Switch Circuit Controller Crank.....	7-9
 A. APPENDIX A – CIRCUIT DRAWINGS.....	 A-1
A.1. GENERAL	A-1

LIST OF FIGURES

Description	Page
Figure 1–1. Model 7R Push Pull Mechanism	1–4
Figure 1–2. Model 7R Switch Circuit Controller Dimensions	1–5
Figure 1–3. Rocker Arm Links Activate Limit Switches	1–6
Figure 1–4. Cams Detail.....	1–7
Figure 1–5. Controller Crank Arm Throw.....	1–8
Figure 2–1. Model 7R Operation	2–2
Figure 2–2. Centering Attachment Location	2–3
Figure 2–3. Centering Attachment Components	2–4
Figure 3–1. Example Mounting	3–4
Figure 3–2. Example Cable Hardware	3–5
Figure 7–1. Model 7R Switch Circuit Controller P/N 53530–039–00	7–3
Figure 7–2. Centering Attachment P/N 53231–003–01	7–8
Figure 7–3. Crank P/N 38660–030–00	7–9
Figure A–1. 7R Switch Circuit Controller Circuit 48950–310–00	A–3
Figure A–2. 7R Switch Circuit Controller Circuit 48950–311–00	A–4
Figure A–3. 7R Switch Circuit Controller Circuit 48950–312–00	A–6
Figure A–4. 7R Switch Circuit Controller Circuit 48950–313–00	A–10

LIST OF TABLES

Description	Page
Table 3–1. Tools Required	3–2
Table 3–2. Components	3–3
Table 3–3. Example Installation Procedure	3–6
Table 3–4. Example Field Indication Adjustment Procedure	3–11
Table 4–1. Preventive Maintenance Equipment	4–1
Table 4–2. Preventive Maintenance Index	4–2
Table 4–3. Lubrication Procedure– 7R Controller and Layout.....	4–3
Table 4–4. Verification Procedure– 7R Controller and Layout	4–5
Table 4–5. Centering Attachment Check Procedure	4–8
Table 6–1. Corrective Maintenance Equipment	6–1
Table 6–2. Limit Switch Removal and Replacement Procedure.....	6–3
Table 6–3. Obstruction Test Procedure.....	6–6
Table 7–1. Model 7R Switch Circuit Controller P/N 53530–039–01 Parts List	7–5
Table 7–2. Centering Attachment P/N 53231–003–01 Parts List	7–8
Table 7–3. Crank P/N 38660–030–00 Parts List	7–10

1. SECTION 1 – GENERAL DESCRIPTION

1.1. SCOPE OF MANUAL

This manual describes the controller hardware, operation, preventive and corrective maintenance, and replaceable parts of the Alstom Model 7R (P/N 53530-039-01) Switch Circuit Controller.

1.2. GENERAL

This section contains the general description and application of the Alstom Model 7R Switch Circuit Controller.

The Model 7R is a rail-mounted switch circuit controller actuated by a push pull mechanism.

It may be used to integrate the positions of various devices with suitable control circuits. It is used to electrically detect the following:

- Switch Point Position (normal or reverse)
- Switch Point Locking
- Derail Operation
- Bridge Locking and Bridge Position (mounted without rail clamp)
- Tunnel Door Position (mounted without rail clamp)
- Slide Detector Actuation (mounted without rail clamp)

In addition, the Model 7R can be used to shunt track circuits or control relay circuits.

1.3. FEATURES

- Rail-Mounted:
 - One 7R Controller for each Switch Point without Front Rod Assembly or one 7R Controller for monitoring two Switch Points connected with a Front Rod Assembly
 - Eliminates need for extended ties required for conventional circuit controller mounting
 - Eliminates need to purchase and add Front Rod Assembly to Layouts
 - Eliminates Track Crew involvement for the installation of a Track-Rod at required locations, or move or replace ties
 - Unit sits minimum of 1” below Head of Rail to avoid Hi-Rail Car Wheels
 - Unit works on all rail sizes 115# and Higher
- Perfect for Dark Territory Environment:
 - Rail mounted “Between the Tie” design minimizes impact of Rail-Creep due to the track bed
 - Solar / Remote Adaptable
- Spare Contacts:
 - 1/8” Early-Warning
- Limit Switches:
 - Double Break
 - Sealed from moisture and dirt
 - No maintenance
 - Gold contacts: 15,000,000 operations mechanical life
 - No springs or contact fingers
 - Compact Design
 - Field replaceable

- Easy Adjustment:
 - Same, proven adjustable cam and rocker design as the Alstom 7K (smaller package)
- Temperature Range (operating):
 - -40 to +70 Celsius
- Dimensions (see Figure 1–2):
 - Length: 15" (38.1 cm)
 - Width: 9.3" (23.6 cm) (Arm and Centering Attachment Included)
 - Height: 5.5" (14 cm)(From Bottom of Rail)
 - Weight: 38 lb (17.2 kg) (7R Controller with Centering Attachment bolted to Rail Clamp)

1.4. FUNCTION

The Model 7R Switch Circuit Controller can provide “circuit-open” or “circuit-closed” indications for any two-position device. It can control relay circuits and shunt track circuits.

Figure 1–1 shows the components of the push pull mechanism used by the Model 7R.

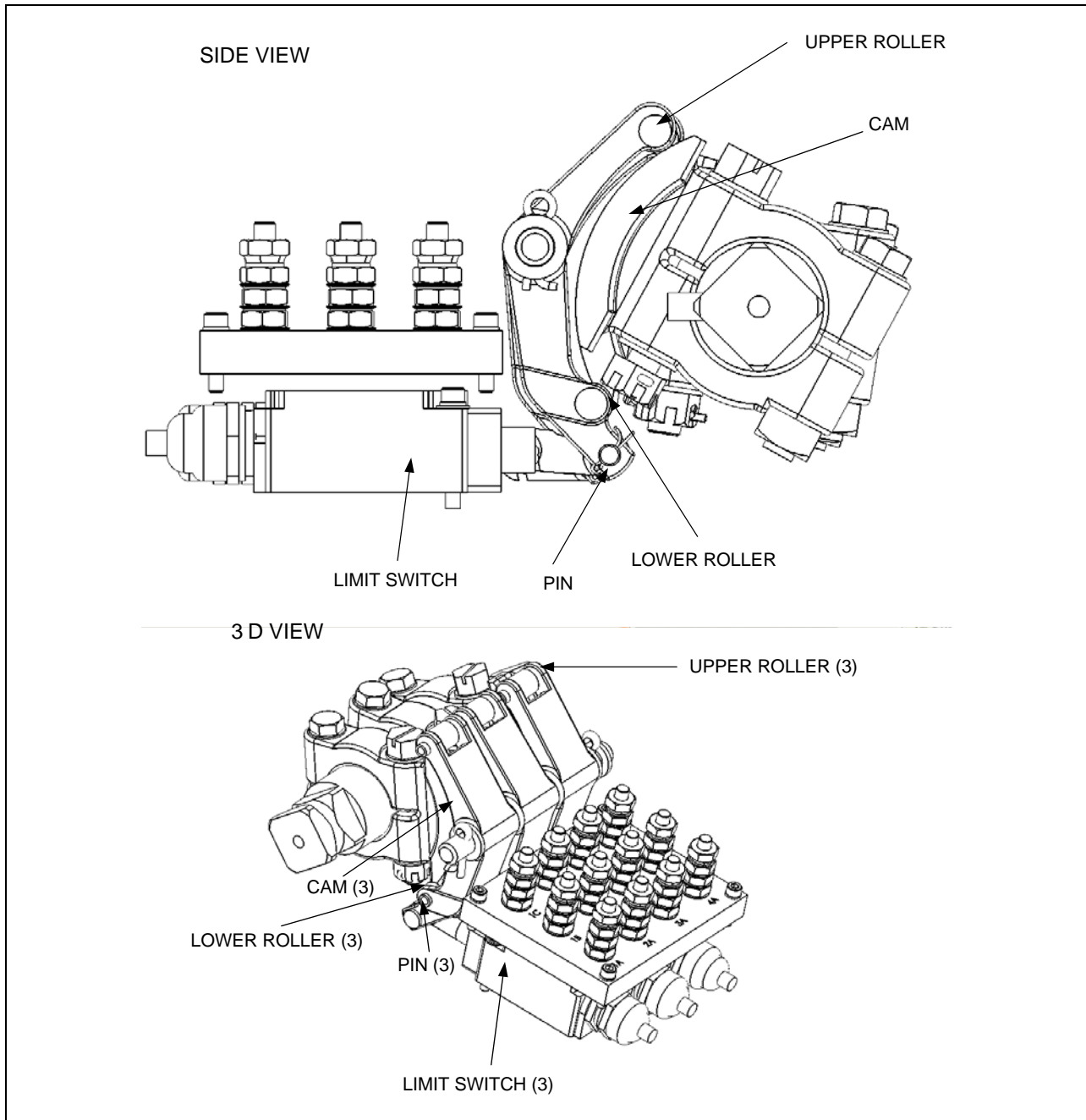

Figure 1–1. Model 7R Push Pull Mechanism

1.5. HARDWARE DESCRIPTION

The Model 7R Switch Circuit Controller assembly is 8.3" (21 cm) wide. The assembly height is 5.5" (14 cm) from the top of the case to the bottom of the rail as shown in Figure 1–2. The assembly is designed to fit inside a tie crib spacing of 11" (28 cm). The average weight of a controller complete with cover is 47 lb (21.3 kg).

The case has a cast aluminum cover that is hinged for ease of maintenance. A gasket in the cover seals the controller against dirt and moisture, and prevents grease and oil from collecting on wires and terminals in the terminal compartment. Screened ventilators in the case equalize internal and external temperatures to prevent the formation of internal condensation.

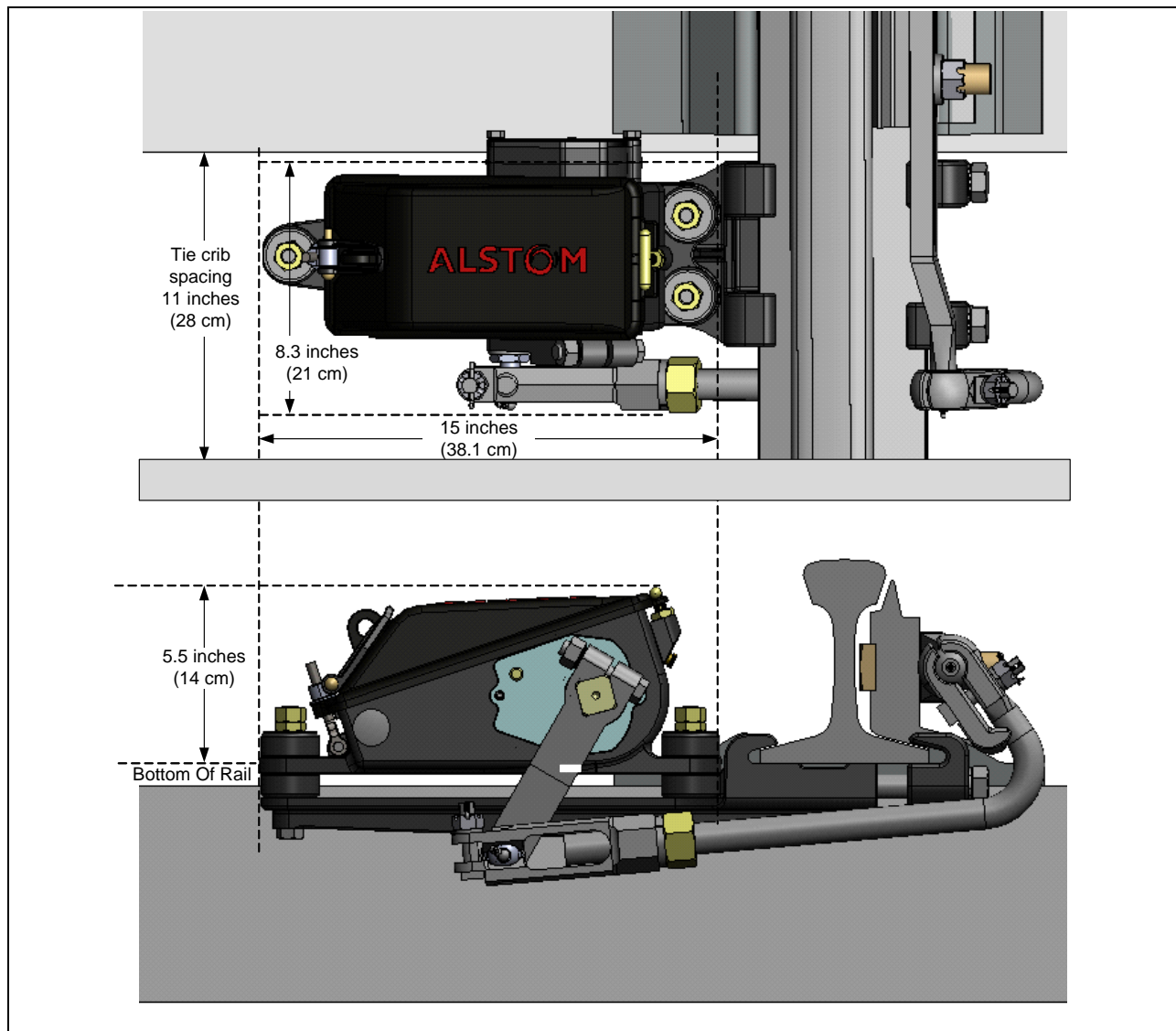

Figure 1–2. Model 7R Switch Circuit Controller Dimensions

Each of the three limit switches is activated by a pin positioned by the cam's push pull motion. Each limit switch has normally open and normally closed contacts. All contacts are gold, double break. The normally closed contacts are also positive break.

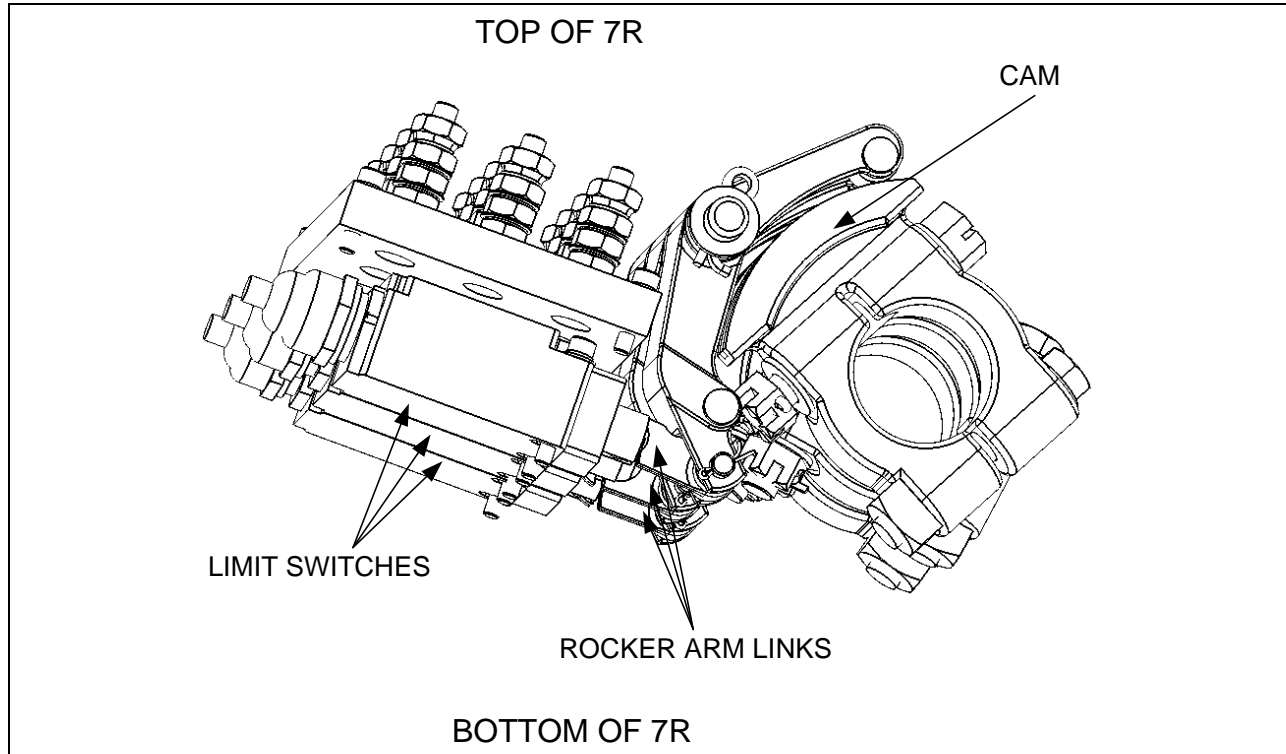

Figure 1–3. Rocker Arm Links Activate Limit Switches

The Model 7R camshaft and cam assemblies consist of a zinc plated, chromate conversion finish steel camshaft; three cast aluminum adjustable cams, with hardened steel inserts; and a camshaft mounted crank arm.

The camshaft is supported by high impact permanent self lubricating bearings. The camshaft is square at each end for mounting the crank arm (right- or left-hand operation) and centering attachment. Cams are mounted on, and rotate with, the camshaft.

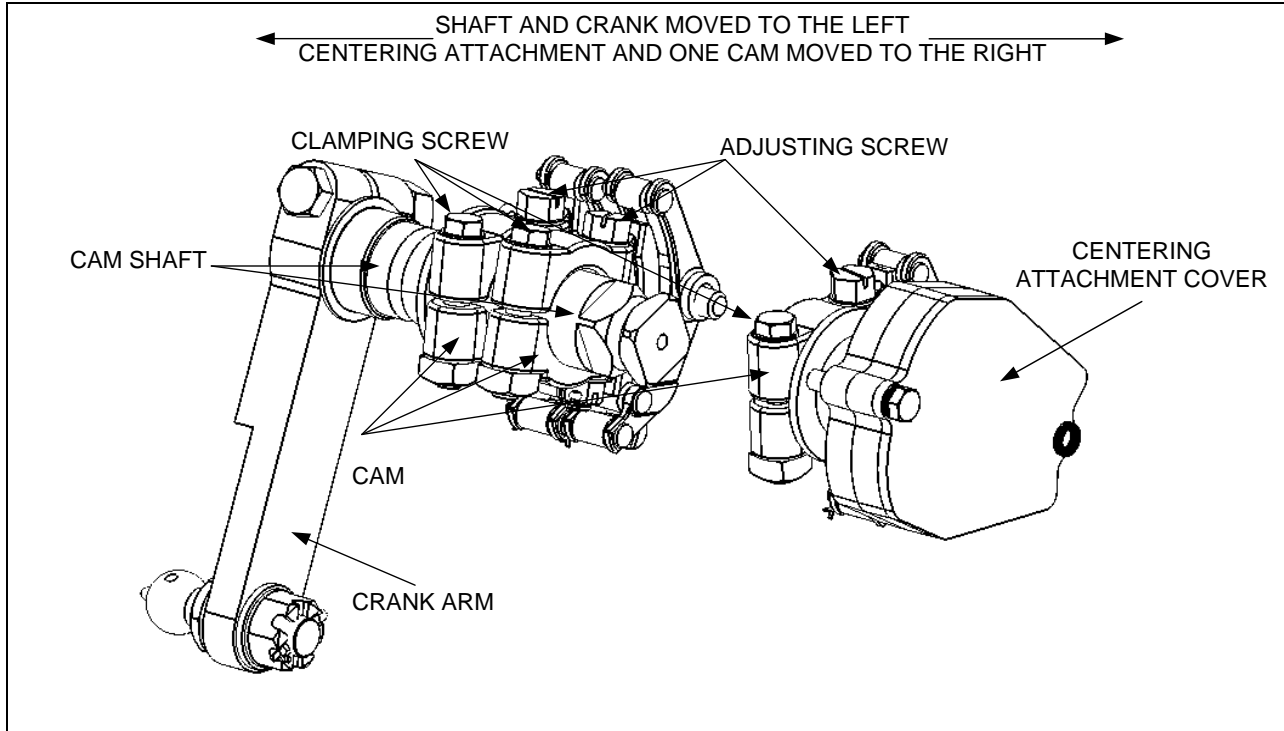

Figure 1-4. Cams Detail

The cams have hardened steel roller surfaces and are equipped with adjusting and clamping screws. The crank arm mounts on the camshaft and transfers motion from a mechanical linkage to the camshaft. Crank arm throw (stroke) dimensions are listed below.

The centering attachment is mounted on the side of the controller and is used to help in the detection of a broken switch rod or disconnected linkage.

The controller arm throw detail is:

- Crank Arm Offset (X) = 6.0"/ 15.24 cm
- Maximum Throw* (Y) = 6.0" / 15.24 cm

*The Maximum permissible connecting rod movement.

See Figure 1-5 for an illustration of the Controller Crank Arm with labeled X and Y coordinates.

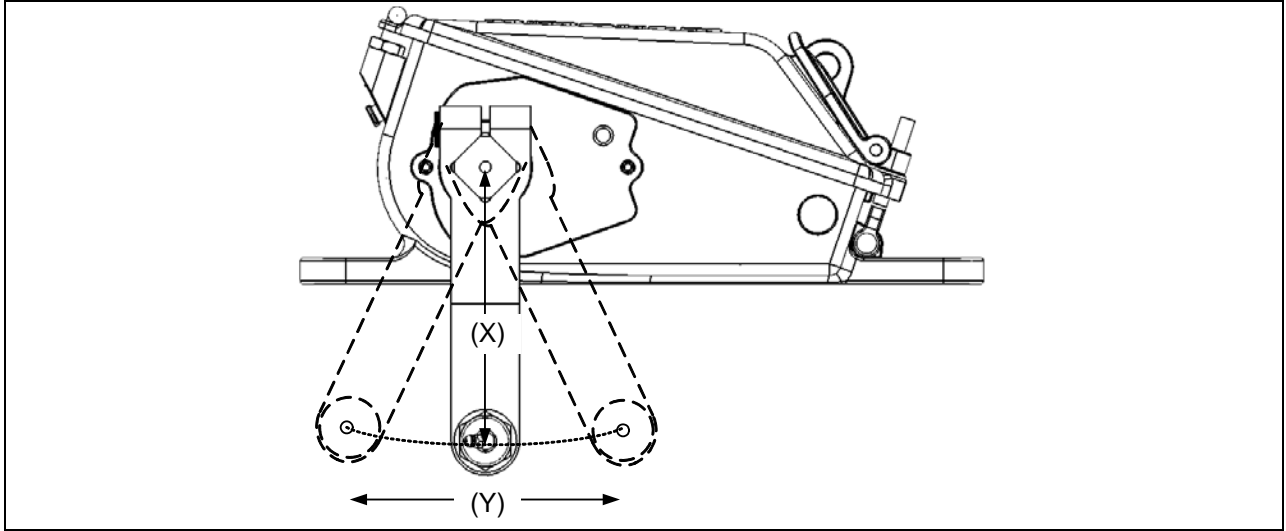

Figure 1-5. Controller Crank Arm Throw

2. SECTION 2 – THEORY OF OPERATION

2.1. GENERAL

This section contains the Theory of Operation of the Alstom Model 7R Switch Circuit Controller.

2.2. OPERATION

The Model 7R Switch Circuit Controller is designed to provide “circuit-open” or “circuit-closed” indications for two-position devices.

A cam and roller are used to actuate the normally open and normally closed contacts on three limit switches.

The controller operates with as little as a 5-degree movement of the crank arm, and is protected from spurious actuation from vibrations. It can be set up for right-hand or left-hand operation and for simultaneous or progressive cam operation.

2.2.1. Model 7R Operation

The Model 7R Switch Circuit Controller rocker arm has two rollers, as shown in Figure 2–1. The cam is in contact with the lower roller as shown in Detail A. This holds the rocker down, which activates the limit switch, opening the normally closed contacts and closing the normally open contacts.

When the crank arm is moved, the rotation causes the cam to contact the upper roller as shown in Detail B. As the camshaft continues to rotate, the cam moving against the upper roller causes the rocker to pivot, which activates the limit switch. This allows the normally closed contacts to close and the normally open contacts to open.

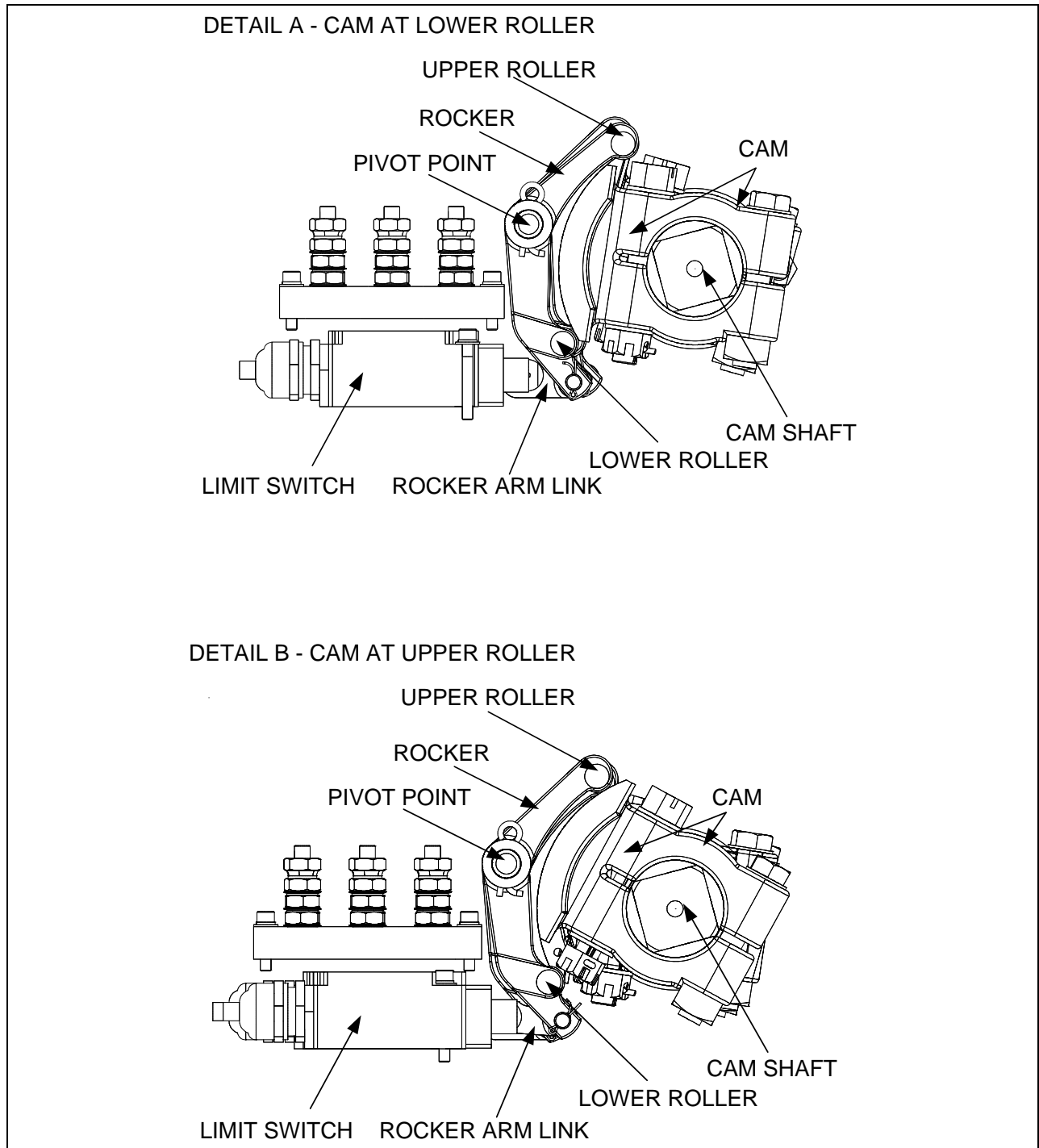

Figure 2-1. Model 7R Operation

2.2.2. Centering Attachment

The centering attachment drives the crank shaft to a position between extremes of crank arm travel, if the connection between the controller and the device whose position is to be determined is lost. For instance, when clearing signals, the attachment helps to prevent a false clear condition when the contacts are adjusted to change state near the end of the travel of the crank arm.

WARNING

THE FUNCTION OF THE CENTERING ATTACHMENT CAN BE DEFEATED IF A BROKEN LINKAGE JAMS TO HOLD THE SHAFT NEAR THE END OF THE STROKE.

With the centering attachment fastened to a shaft that has been rotated away from its dead centering position, a trapped spring in the attachment is further compressed to create a “restoring” torque of over 150 inch-pounds on the shaft. This torque is reduced somewhat by friction in the switch circuit controller end of the attachment.

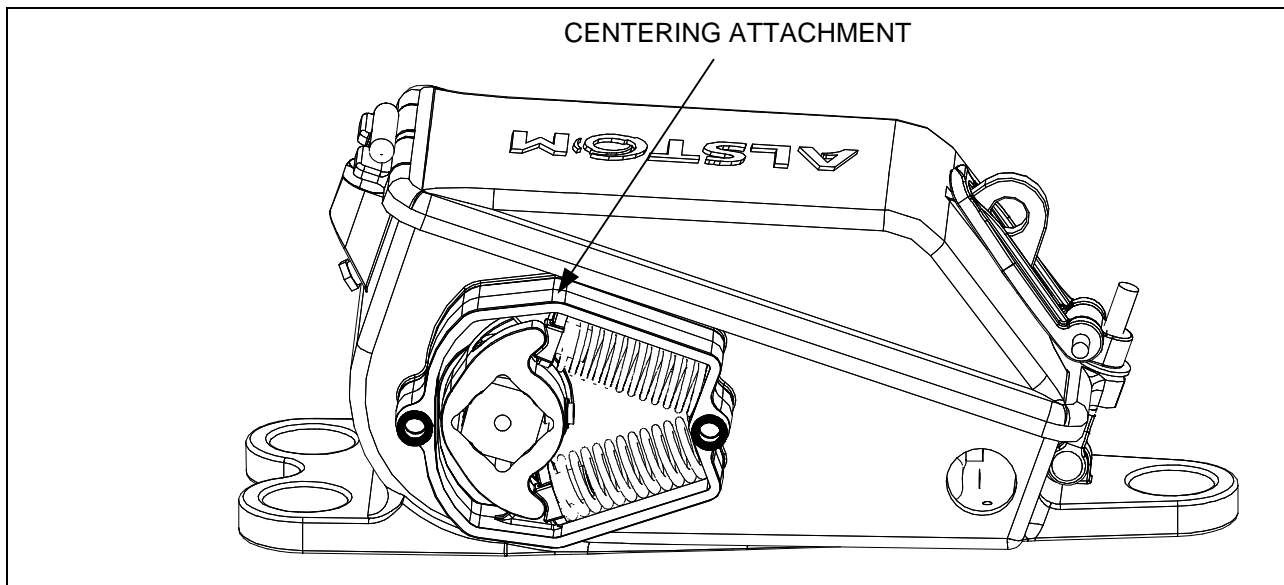

Figure 2–2. Centering Attachment Location

Figure 2–3 shows the centering attachment location installed, with its cover removed.

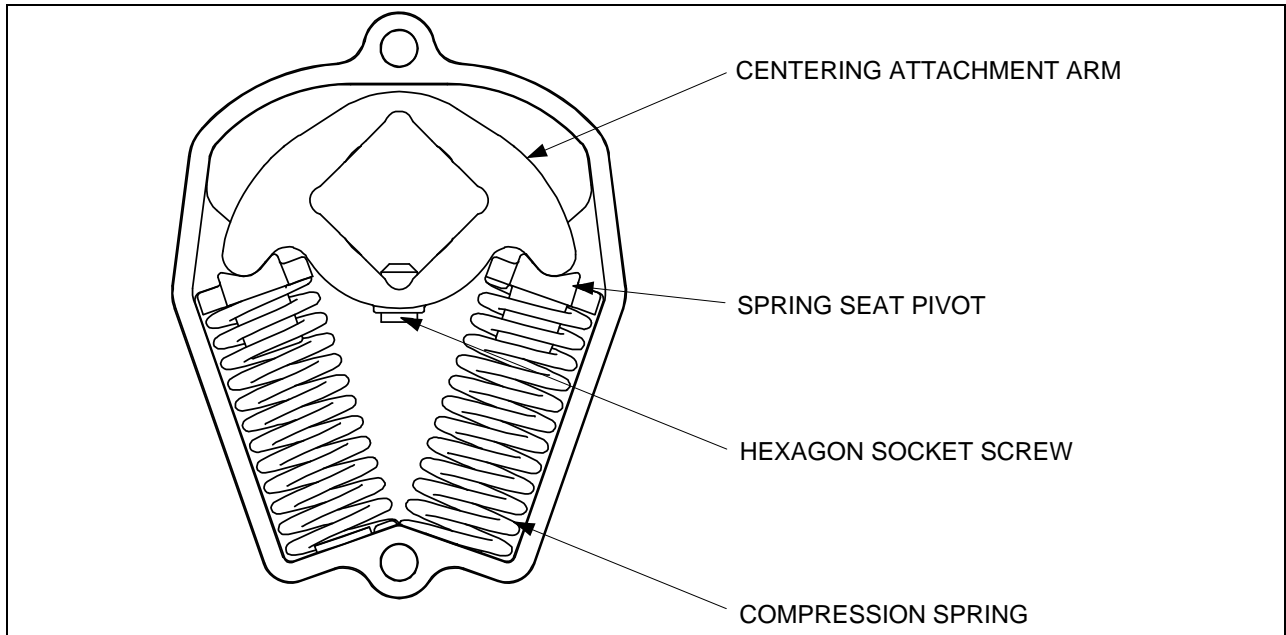

Figure 2–3. Centering Attachment Components

3. SECTION 3 – INSTALLATION

3.1. GENERAL

This section contains the installation and adjustment information for the Alstom Model 7R Switch Circuit Controllers.

3.2. APPLICATIONS

Alstom Model 7R Switch Circuit Controllers can be used for multiple applications, as discussed in Section 1. The installation configuration is determined by the intended application. Therefore, installation configurations vary.

The location Book of Plans details the component location and wiring information. Always refer to the Book of Plans for installation reference.

3.3. EXAMPLE WIRING DIAGRAMS

Example wiring diagrams are provided in Appendix A.

NOTE

Switch leads are assembled to terminal posts per the drawing provided in Figure A–2. The as shipped wiring configuration is per circuit P/N 48950-311-00. This circuit is for monitoring both the normal and reverse point positions when one 7R Controller is used and installed on the normal point side and a front rod assembly is connected between the point rails. For other application circuits for this product, see Appendix A, which also includes:

Circuit 48950-310-00 - For use when monitoring the normal point only when one 7R Controller is installed on the normal point side and no front rod assembly is connected between the point rails. (See Figure A–1).

Circuit 48950-312-00 - For use when monitoring both the normal and reverse point positions when two 7R Controllers are installed and no front rod assembly is connected between the point rails. (See Figure A–3).

Circuit 48950-313-00 - For use when monitoring the normal points only in a crossover when one 7R Controller is installed on the normal point of each switch and no front rod assemblies are connected between the point rails. (See Figure A–4).

WARNING

ANY DEVIATION FROM THE WIRING CIRCUITS PROVIDED IN APPENDIX A MUST BE APPROVED BY AN ALSTOM SAFETY OFFICER.

3.4. REQUIRED INSTALLATION EQUIPMENT

Table 3–1. Tools Required

Quantity	Description
1	9/16" Deep Well Socket
1	¾" Combination Wrench
1	7/8" Deep Well Socket
1	1-1/8" Socket
1	1-5/8" Combination Wrench
1	5/32" Ball end Allen Wrench
1	Pliers
1	Pry Bar
1	Flathead Screwdriver (large size and fit in 1/16" slot)
1	AAR Wrench
1	Wrench (fit 9/16" hex bolt head)
1	Multimeter (Continuity Tester)
1	Switch Point Obstruction Gauge: 1/8" and 1/4" (depending on customer requirements)
As Required	Anti-Seize Grease
As Required	Lithium-Based, Multi-Temperature, Extreme Pressure Grease in Grease Gun

3.5. INSTALLATION PROCEDURE

The installation process includes:

- Mounting of ball end point lug to the switch point
- Mounting of 7R Switch Circuit Controller to the rail
- Attaching the J-rod to the crank
- Attaching the crank to the shaft of the 7R and the ball socket to the ball end of the point lug

An example installation procedure is provided in Table 3–3. The connection to switch point, rails, and whether a front rod assembly is used is application and authority specific. See the location Book Of Plans for the specific installation configuration.

Each 7R Controller must be wired according to an approved configuration provided in Appendix A.

WARNING

ANY DEVIATION FROM THE WIRING CIRCUITS PROVIDED IN APPENDIX A MUST BE APPROVED BY AN ALSTOM SAFETY OFFICER.

Installation is followed by the Field Indication Adjustment Procedure provided in Table 3–4.

Table 3–2. Components

Quantity	Part Number	Description
1	58667-003-00	7R Switch Circuit Controller Mounted to Support Clamp
1	43053-385-00	Point Lug, Switch Layout, Ball End
1	45512-088-00	Rod Comp, Switch Layouts, Ball End

The example mounting shown in Figure 3–1 identifies many of the components used in a typical mounting configuration. Figure 3–2 shows example configurations with the hardware for one and two field wiring cables installed. Refer to the location Book Of Plans for the details of a specific installation.

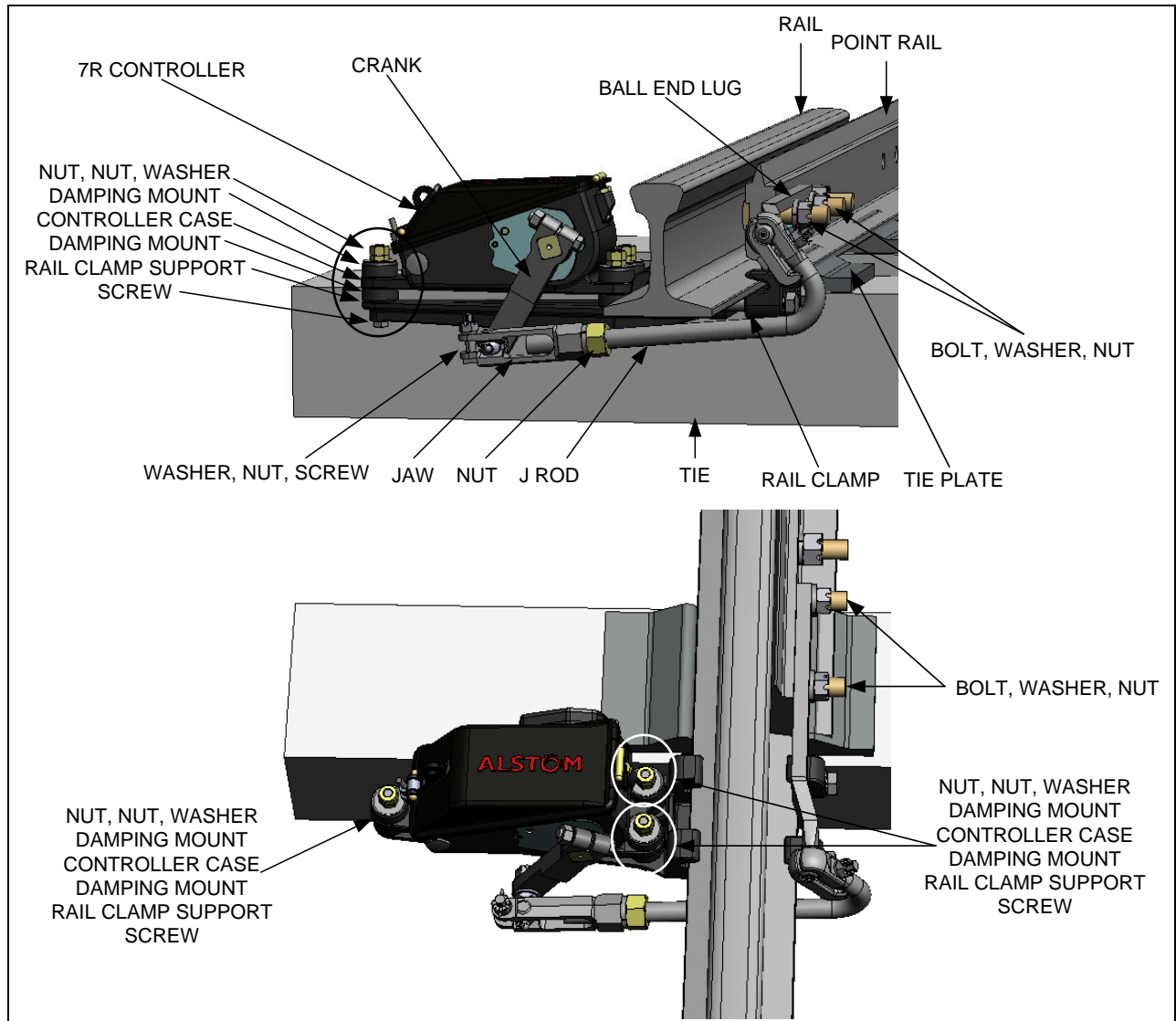

Figure 3–1. Example Mounting

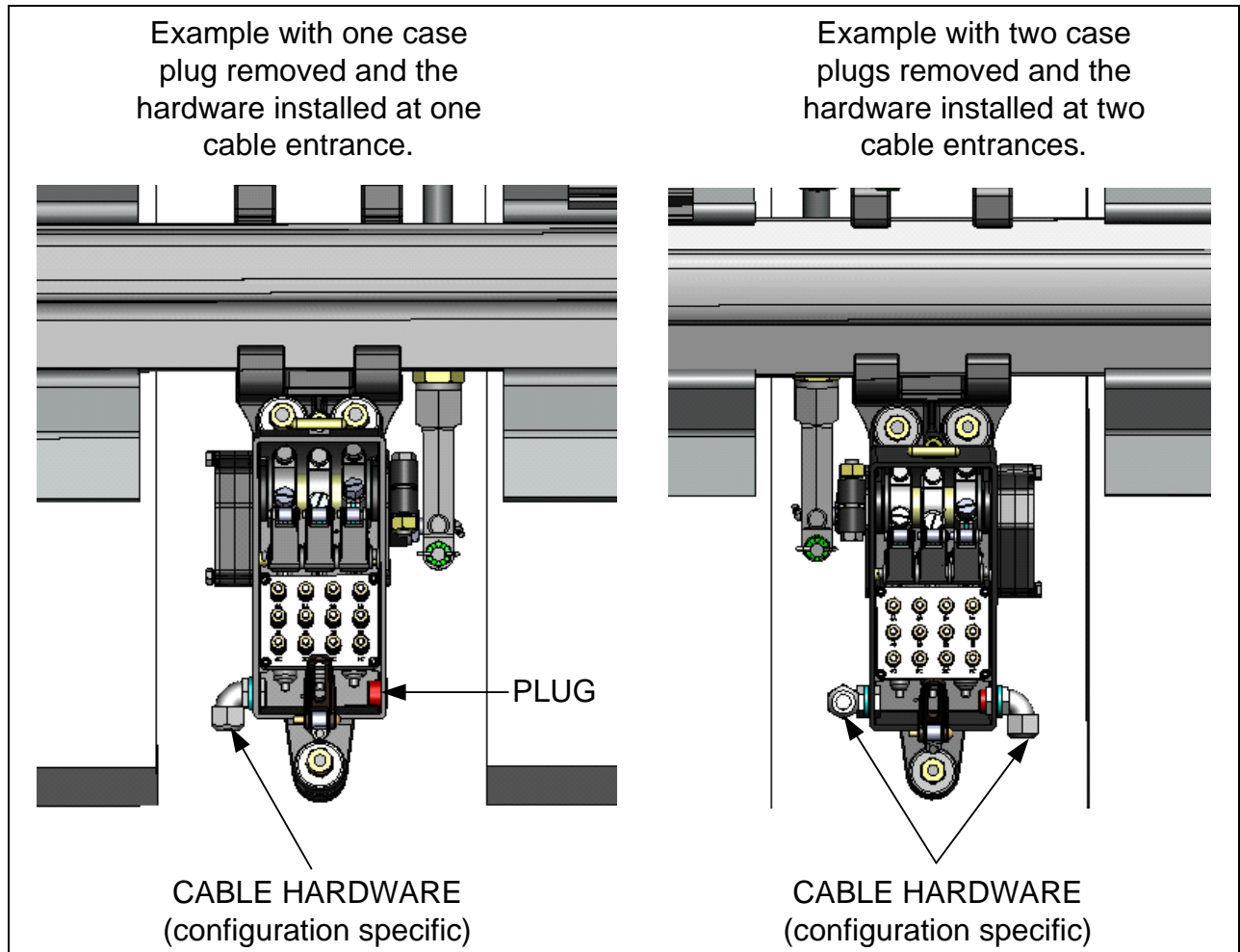

Figure 3–2. Example Cable Hardware

Table 3–3. Example Installation Procedure

Step	Procedure
<p>1</p>	<p>Move centering device to the opposite side of the unit if necessary. Set screw should be torqued to 8 ft-lb. Install gaskets between spring housing and 7R Controller case and between spring housing and cover. Mounting bolts should be torqued to 9 ft-lb.</p> 
<p>2</p>	<p>Loosely assemble the ball end lug onto the switch point as shown.</p> 

Table 3–3. Example Installation Procedure (Cont.)



Step	Procedure
3	<p>Open the cover and make sure that the cams are in a position that allows for easy adjustment once the crank is installed.</p> 
4	<p>Put the 7R in place on outside of the rail.</p> 
5	<p>Install the included clamps, wedge-lock washers and bolts on the inside of the rail. Apply anti-seize grease to the bolt threads.</p> 

Table 3–3. Example Installation Procedure (Cont.)

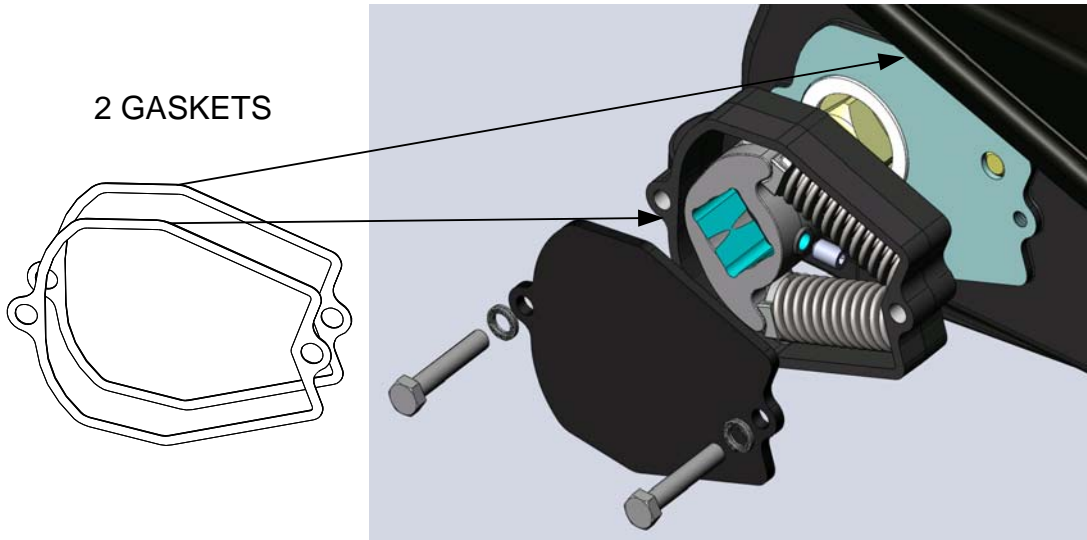
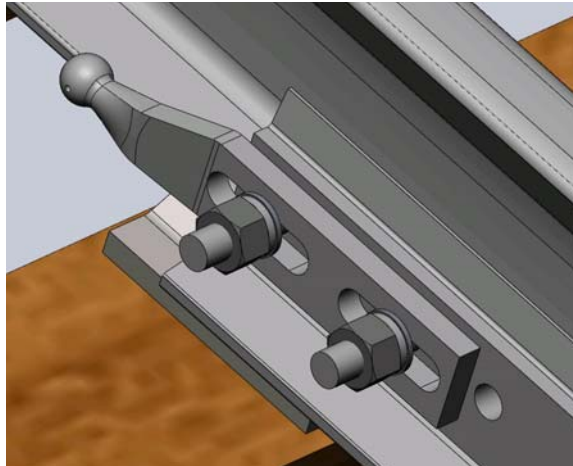
Step	Procedure
6	<p>Attach J-rod to crank, verifying required orientation. Tighten the nut until the clamp is snug on the ball, but not binding, and secure it using a cotter pin.</p> 
7	<p style="text-align: center;"><u>NOTE</u></p> <p>Steps 7 through 11 ensure that the compression springs inside the centering attachment on the 7R Controller are evenly compressed for both normal and reverse positions. Failure to correctly adjust the J-rod length may shorten the lives of the compression springs.</p> <p>Set the point rails to mid-stroke. There should be equal distance between the stock rails and the point rails on each side of the track.</p> 
8	<p>Use a 1-5/8" open wrench to loosen the 1.00" nut where the J-rod enters the jaw connector on the 7R Controller.</p>
9	<p>With the crank on the 7R Controller in a vertical (90°) position, rotate the J-rod until it reaches the ball end lug, and then tighten the nut at the base of the J-rod (see the figure in Step 6 for the location of the nut).</p>

Table 3–3. Example Installation Procedure (Cont.)

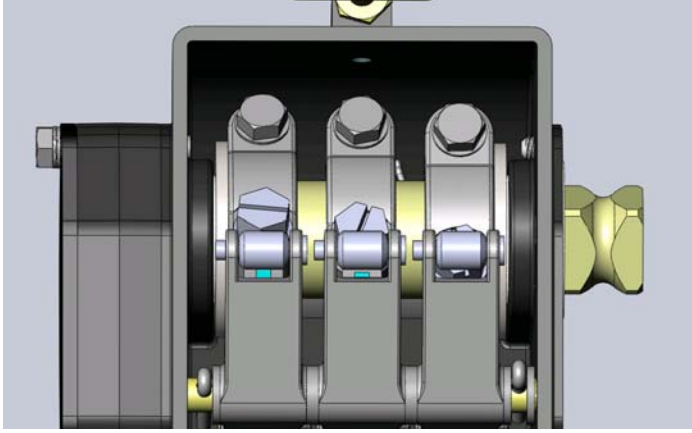
Step	Procedure
10	<p>Attach the ball socket on the end of the J-rod to the ball end of the lug. Tighten the nut until the jaws are tight and the ball is snug, not binding. Secure it using a cotter pin.</p> 
11	<p>Tighten all hardware as follows: rail clamps to 200 ft-lb. and crank to 35 ft-lb.</p>  <p>Tighten to 35 ft-lb.</p> <p>Tighten to 200 ft-lb.</p>
12	<p>Grease the two fittings on the ball ends.</p>
13	<p>Refer to the location Book Of Plans for cable and wiring specifications. Locate the circuit in Appendix A for the controller application and determine the internal wiring configuration for the Controller.</p>

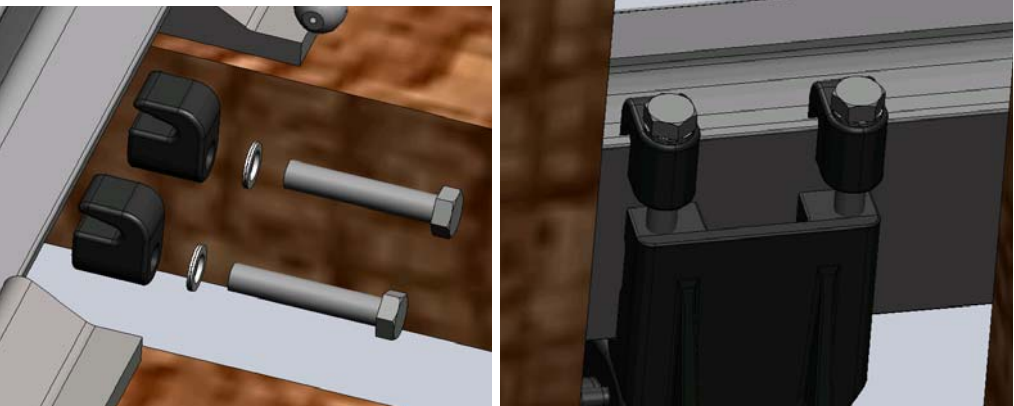
Table 3–3. Example Installation Procedure (Cont.)

Step	Procedure
14	<p>Each 7R Controller must be wired according to an approved configuration provided in Appendix A.</p> <p style="text-align: center;"><u>WARNING</u></p> <p style="text-align: center;">ANY DEVIATION FROM THE WIRING CIRCUITS PROVIDED IN APPENDIX A MUST BE APPROVED BY AN ALSTOM SAFETY OFFICER.</p> <p style="text-align: center;">ATTACH THE LABELED INTERNAL WIRES TO THE APPROPRIATE POSTS, PER THE APPLICATION CIRCUIT.</p>
15	<p>Remove the appropriate plugs covering the holes for field wiring cables.</p> <div style="text-align: center;">  </div> <p>In single 7R Controller applications only one plug is removed. When a configuration includes two 7R Controllers as in the example provided in Figure A–1, both plugs are removed from one Controller while one plug is removed from the other. Refer to the location Book Of Plans for layout specifics.</p>
16	<p style="text-align: center;"><u>WARNING</u></p> <p style="text-align: center;">VERIFY POWER IS NOT APPLIED TO THE CABLES THAT ARE TO BE RUN TO THE CONTROLLER. FAILURE TO DO SO MAY CAUSE INJURY FROM ELECTRICAL SHOCK.</p> <p>Run the appropriate field wiring cables to the 7R Controller using the hardware designated in the layout drawing in the location Book Of Plans.</p>
17	<p>Perform the Field Indication Adjustment provided in Table 3–4.</p>

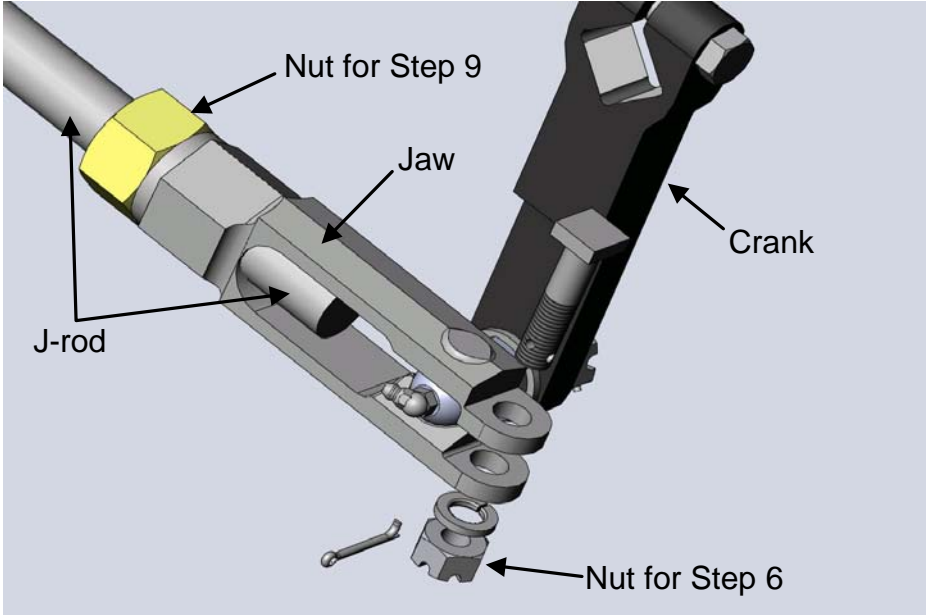
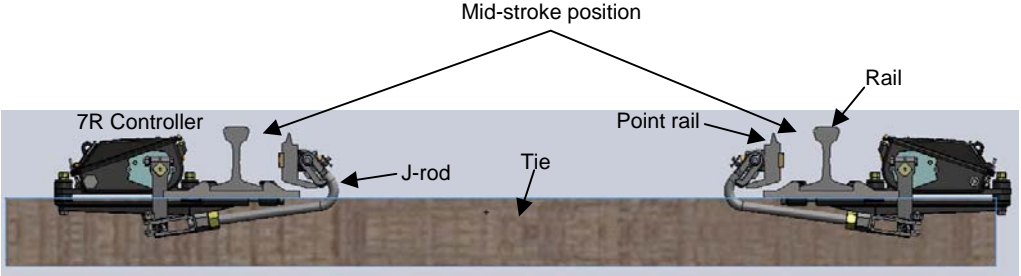
3.6. FIELD INDICATION ADJUSTMENT

After installing a Model 7R circuit controller, perform the field indication adjustment procedure. An example procedure for a two controller configuration is provided in Table 3–4.

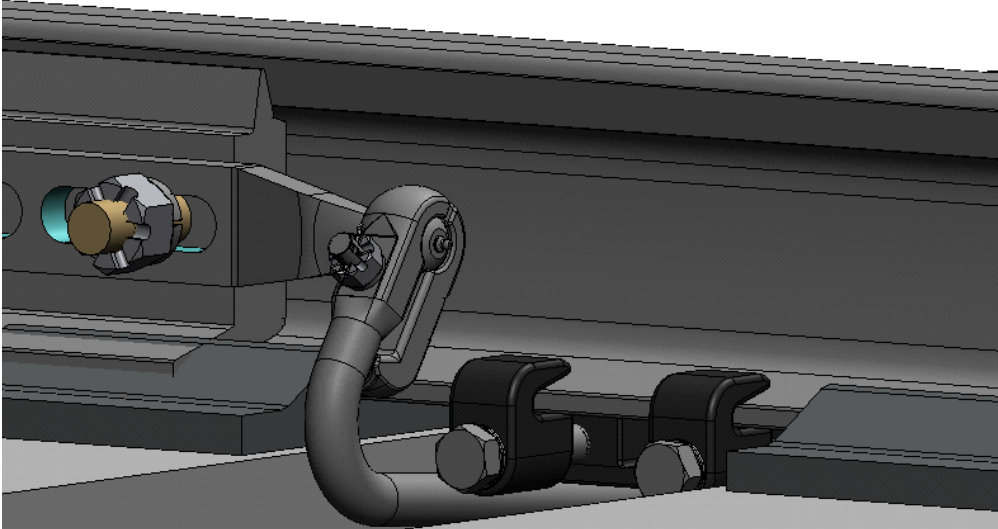
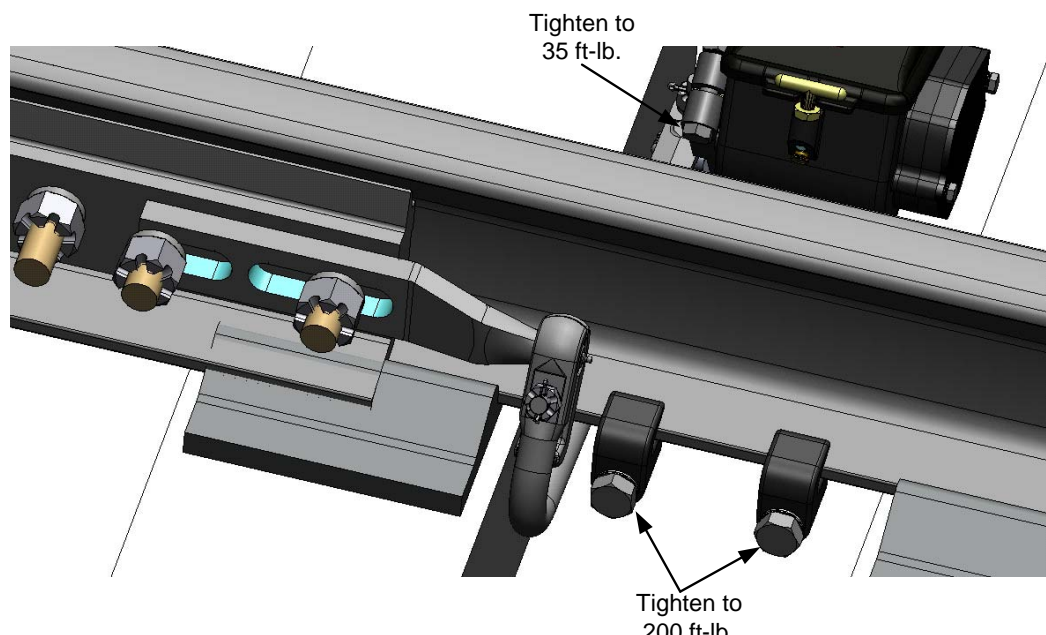
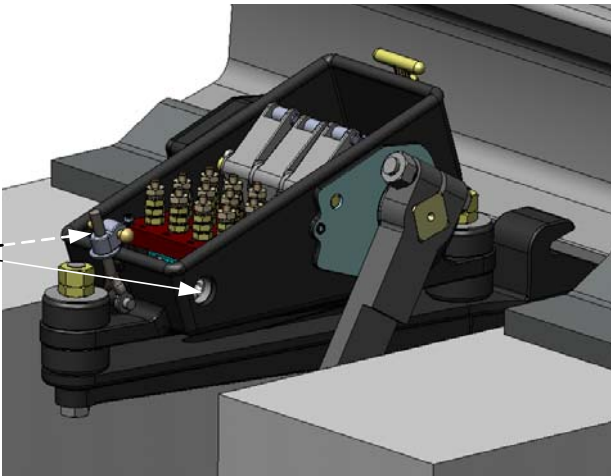
Tools Required:

- Flat Head Screwdriver, (large size and fit in 1/16" slot)
- Wrench (fit 9/16" hex bolt head)
- Continuity Tester
- Switch Point Obstruction Gauge: 1/8" and 1/4" (depending on customer requirements)

WARNING

DISCONNECT MOTOR ENERGY WHENEVER MAKING ADJUSTMENTS TO THE SWITCH LAYOUT OR SWITCH MACHINE. UNEXPECTED OPERATION OF THE MACHINE COULD CAUSE INJURY FROM OPEN GEARS, ELECTRICAL SHOCK, OR MOVING PARTS.

Table 3–4. Example Field Indication Adjustment Procedure

Step	Procedure
1	7R Controller adjustment varies, depending on the application circuit. Locate the circuit in Appendix A for the controller application and determine which limit switches are to be adjusted for normal point detect and reverse point detect, as appropriate. Then use the circuit to determine which terminal posts to use for continuity detection during the adjustment procedure. The following procedure uses example circuit 48950-312-00, provided in Figure A–3. This circuit is for application where two 7R Controllers are used without front rod assembly to monitor both normal and reverse point positions at all times.
2	Verify power is removed from the 7R Controller.
3	Verify all connection rods and lugs are properly connected and aligned, and all bolts and nuts are secure.

Table 3–4. Example Field Indication Adjustment Procedure (Cont.)

Step	Procedure
4	<p>Remove the padlock and cover (if installed) on the 7R Controller(s) to be adjusted.</p> 
5	<p style="text-align: center;">Adjust 7R circuit controllers for the normal indication</p> <p>Move the switch point to the normal position with ¼" switch point obstruction gauge inserted in between the switch point and stock rail.</p>
6	<p><u>Adjust the continuity for the normal indication on the normal side 7R Controller (Cam 1)</u></p> <p>Connect the continuity tester between 7R indication contacts on terminal posts 2A and 2C on the 7R Controller located on the normal side.</p> 

Table 3-4. Example Field Indication Adjustment Procedure (Cont.)

Step	Procedure
7	<p style="text-align: center;"><u>CAUTION</u></p> <p>During this procedure the jam screw is only loosened (approximately ¼ turn) until the adjusting screw can move with resistance. <u>If the jam screw is loosened too much</u>, the adjusting screw will turn freely and the cam will lose its fine adjustment.</p> <p>Back off the jam screw for Cam No.1 with 9/16" wrench until the adjusting screw can barely turn (with resistance). This allows for fine tuning of the cam.</p>  <p>Turn the adjusting screw counter-clockwise until there is continuity on terminal posts 2A and 2C, and then turn the adjustment screw slowly in the opposite direction until the continuity just breaks. Tighten the jam screw.</p>
8	<p><u>Adjust the continuity for the normal shunted contacts on the normal side 7R Controller (Cam 3)</u></p> <p>Connect the continuity tester between 7R contacts on terminal posts 3A and 3B on the 7R Controller located on the normal side.</p>

Table 3–4. Example Field Indication Adjustment Procedure (Cont.)

Step	Procedure
9	<p style="text-align: center;"><u>CAUTION</u></p> <p>During this procedure the jam screw is only loosened (approximately ¼ turn) until the adjusting screw can move with resistance. <u>If the jam screw is loosened too much</u>, the adjusting screw will turn freely and the cam will lose its fine adjustment.</p> <p>Back off the jam screw for Cam No.3 with 9/16” wrench until the adjusting screw can barely turn (with resistance). This allows for fine tuning of the cam.</p> <p>Turn the adjusting screw clockwise until the shunt contacts on terminal posts 3A and 3B just make. Tighten the jam screw.</p>
10	<p style="text-align: center;"><u>Adjust the continuity for the normal indication on the reverse side 7R Controller (Cam 2)</u></p> <p>Connect the continuity tester across indication contacts at terminal posts 2B and 3B of 7R at reverse side.</p>
11	<p style="text-align: center;"><u>CAUTION</u></p> <p>During this procedure the jam screw is only loosened (approximately ¼ turn) until the adjusting screw can move with resistance. <u>If the jam screw is loosened too much</u>, the adjusting screw will turn freely and the cam will lose its fine adjustment.</p> <p>Back off the jam screw for Cam No.2 with 9/16” wrench until the adjusting screw can barely turn (with resistance). This allows for fine tuning of the cam.</p> <p>Turn the adjusting screw-clockwise until there is continuity at terminal posts 2B and 3B, and then turn the adjustment screw slowly counter-clockwise until the continuity breaks. Tighten the jam screw.</p>
12	<p>Open the switch point and remove the 1/4” switch point obstruction gauge. Move the switch point to the normal position with the 1/8” switch point obstruction gauge inserted between the switch point and stock rail.</p>
13	<p>Verify that continuity exists between terminal posts 2A and 2C of 7R at normal side and between terminal posts 2 Band 3B of 7R at reverse side.</p>
14	<p>If there is no continuity, repeat Steps 5 through 13.</p>

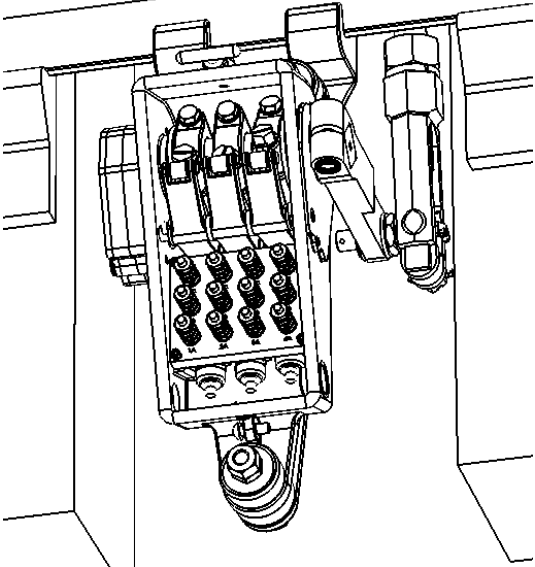
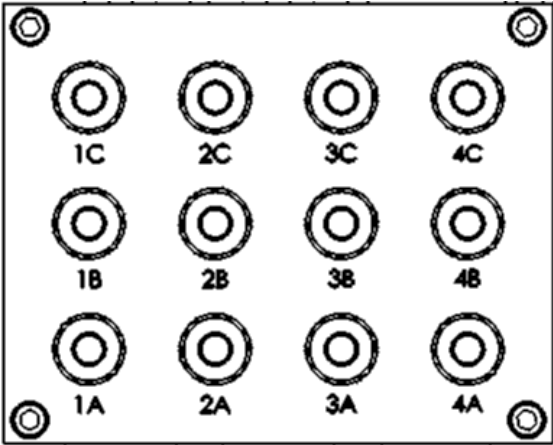
Table 3–4. Example Field Indication Adjustment Procedure (Cont.)

Step	Procedure
15	<p style="text-align: center;">Adjust the 7R circuit controllers for reverse indication</p> <p>Move the switch point to the reverse position with ¼” switch point obstruction gauge inserted in between the switch point and stock rail.</p>
16	<p style="text-align: center;"><u>Adjust the continuity for the reverse indication on the reverse side 7R Controller (Cam 1)</u></p> <p>Connect the continuity tester between 7R indication contacts on terminal posts 1A and 2C on the 7R Controller located on the reverse side.</p>
17	<p style="text-align: center;"><u>CAUTION</u></p> <p>During this procedure the jam screw is only loosened (approximately ¼ turn) until the adjusting screw can move with resistance. <u>If the jam screw is loosened too much</u>, the adjusting screw will turn freely and the cam will lose its fine adjustment.</p> <p>Back off the jam screw for Cam No.1 with 9/16” wrench until the adjusting screw can barely turn (with resistance). This allows for fine tuning of the cam. Turn the adjusting screw counter-clockwise until there is continuity, and then turn the adjustment screw slowly in the opposite direction until the continuity just breaks. Tighten the jam screw.</p>
18	<p style="text-align: center;"><u>Adjust the continuity for the reverse shunted contacts on the reverse side 7R Controller (Cam 3)</u></p> <p>Connect the continuity tester between 7R indication contacts on terminal posts 3A and 3B on the 7R Controller located on the reverse side.</p>
19	<p style="text-align: center;"><u>CAUTION</u></p> <p>During this procedure the jam screw is only loosened (approximately ¼ turn) until the adjusting screw can move with resistance. <u>If the jam screw is loosened too much</u>, the adjusting screw will turn freely and the cam will lose its fine adjustment.</p> <p>Back off the jam screw for Cam No.3 with 9/16” wrench until the adjusting screw can barely turn (with resistance). This allows for fine tuning of the cam. Turn the adjusting screw clockwise until the shunt contacts on terminal posts 3A and 3B just make. Tighten the jam screw.</p>

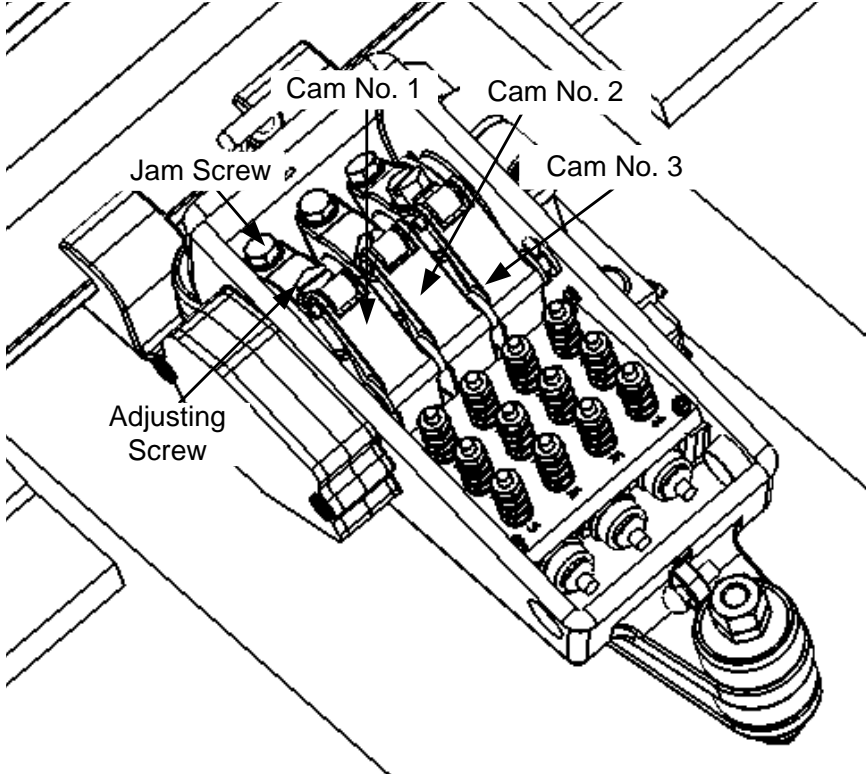
Table 3–4. Example Field Indication Adjustment Procedure (Cont.)

Step	Procedure
20	<p><u>Adjust the continuity for the reverse indication on the normal side 7R Controller (Cam 2)</u></p> <p>Connect the continuity tester between 7R indication contacts on terminal posts 2B and 3B on the 7R Controller located on the normal side.</p>
21	<p style="text-align: center;"><u>CAUTION</u></p> <p>During this procedure the jam screw is only loosened (approximately ¼ turn) until the adjusting screw can move with resistance. <u>If the jam screw is loosened too much</u>, the adjusting screw will turn freely and the cam will lose its fine adjustment.</p> <p>Back off the jam screw for Cam No.2 with 9/16” wrench until the adjusting screw can barely turn (with resistance). This allows for fine tuning of the cam. Turn the adjusting screw clockwise until there is continuity at terminal posts 2B and 3B, and then turn the adjustment screw counter-clockwise until the continuity just breaks. Tighten the jam screw.</p>
22	<p>Open the switch point and remove the 1/4” switch point obstruction gauge. Move the switch point to the reverse position with the 1/8” switch point obstruction gauge inserted between the switch point and stock rail.</p>
23	<p>Verify that continuity exists between terminal posts 1A and 2C of 7R at reverse side and between terminal posts 2B and 3B of 7R at normal side.</p>
24	<p>If there is no continuity, repeat Steps 15 through 23.</p>
25	<p>Apply power to the 7R Controller.</p>
26	<p>Verify at the control room, for both the normal and reverse switch positions, that there is no indication with a 1/4” obstruction and that there is indication with an 1/8” obstruction.</p>

4. SECTION 4 – PREVENTIVE MAINTENANCE

4.1. GENERAL

This section contains the preventive maintenance procedures for the Alstom Model 7R Switch Circuit Controller. It includes a list of the required test equipment, lubrication procedures, and checks and adjustments.

4.2. REQUIRED TEST EQUIPMENT

The materials the maintainer needs to perform routine preventive maintenance on the Model 7R controllers are provided in Table 4–1.

Table 4–1. Preventive Maintenance Equipment

Equipment	Manufacturer/Model
Spring Force Gauge: 0-30 lb or more	Any
Grease: Lithium-Based, Multi-Temperature, Extreme Pressure	Alstom 91A0012 or Equivalent
Oil: Low Temperature Mineral Base Oil	Alstom 91A0007 (P/N 81379-005-08) or Equivalent

4.3. PREVENTIVE MAINTENANCE INDEX

Table 4–2 lists the suggested preventive maintenance for the Model 7R controllers. The interval column contains the recommended interval for all scheduled maintenance actions covered in this section. The maintenance action column lists the maintenance action to be performed. The table number column indicates the table that contains the associated procedure(s).

Table 4–2. Preventive Maintenance Index

Interval	Maintenance Action	Table Number
Quarterly	Lubrication Procedure - 7R Controller and Layout	4–3
Quarterly	Verification Procedure - 7R Controller and Layout	4–4
Annually	Centering Attachment Check Procedure	4–5

CAUTION

Before attempting preventive or corrective maintenance on the controller, ensure that all mechanical linkages have been disconnected. Do this by verifying crank arm is positioned vertically and unloaded.

Make sure the linkage to the arm cannot move. Remove cover for centering attachment. Loosen setscrew on arm. Remove attachment before doing any maintenance. After maintenance is complete, reassemble parts and restore controller layout to its normal function.

4.4. LUBRICATION

The following describe lubrication procedures for Alstom Model 7R Switch Circuit Controller and Layout.

It is best to lubricate the controller before placing it into service. During normal operation, the controller is to be lubricated every three months, or whenever it has been flooded, in accordance with the following information. Lubrication of controller parts prevents galling and excessive wear, reduces internal forces, excludes contaminants, and prevents corrosion.

To perform the lubrication, follow the procedure in Table 4–3. Avoid the use of too much grease or oil. Clean any surfaces that have an excess accumulation of lubricant. By not permitting grease or oil to collect, or drop on wires, contact surfaces, or terminals, minimum unscheduled maintenance will be required.

Table 4–3. Lubrication Procedure– 7R Controller and Layout

Step	Procedure
1	Remove the two screws on the centering attachment cover and remove the cover and gasket.
2	Open the top cover of the switch circuit controller.
3	Visually inspect the condition of all internal controller parts.
4	Lubricate cover hinge pins, cover latch pins and exposed threads of adjustable cover latch with Low Temperature Mineral Based Oil, such as Alstom 91A0007.
5	<p>Lubricate contact assembly rollers and pins with Low Temperature Mineral Based Oil, such as Alstom 91A0007. Wipe off any excess oil.</p> <p>Lubricate cam surfaces with a light film of Lithium-Based, Multi-Temperature, Extreme Pressure Grease, such as Alstom 94A0012.</p> 

Table 4-3. Lubrication Procedure- 7R Controller and Layout (Cont.)

Step	Procedure
6	<p>Lubricate 2 surfaces of the centering attachment arm in the centering attachment with Lithium-Based, Multi-Temperature, Extreme Pressure Grease, such as Alstom 91A0012, as shown. Lubricate surfaces where the rocker arm contacts the spring seats (pivots).</p>  <p>The diagram illustrates the centering attachment mechanism. On the left, a perspective view shows the 'ALSTOM' branded centering attachment arm. On the right, a cross-sectional view shows the arm's interaction with the 'SPRING SEAT PIVOT' and 'COMPRESSION SPRING' within the controller's housing. Arrows point from the text labels to the corresponding parts in the cross-section.</p>
7	Inspect gaskets between centering attachment and case and between cover and centering attachment. Replace gaskets if necessary.
8	Close cover and install the two screws removed in Step 1 to secure cover.
9	<p>If external crank or point lug have grease fittings lubricate with Lithium-Based, Multi-Temperature, Extreme Pressure Grease, such as Alstom 91A0012.</p> <p>Otherwise, apply Lithium-Based, Multi-Temperature, Extreme Pressure Grease, such as Alstom 91A0012, to connection rod surfaces where wear can occur.</p>

4.5. VERIFICATION

The Verification Procedure is an inspection procedure for the Model 7R controller and layout. Perform the procedure provided in Table 4–4 a minimum of every 3 months (quarterly).

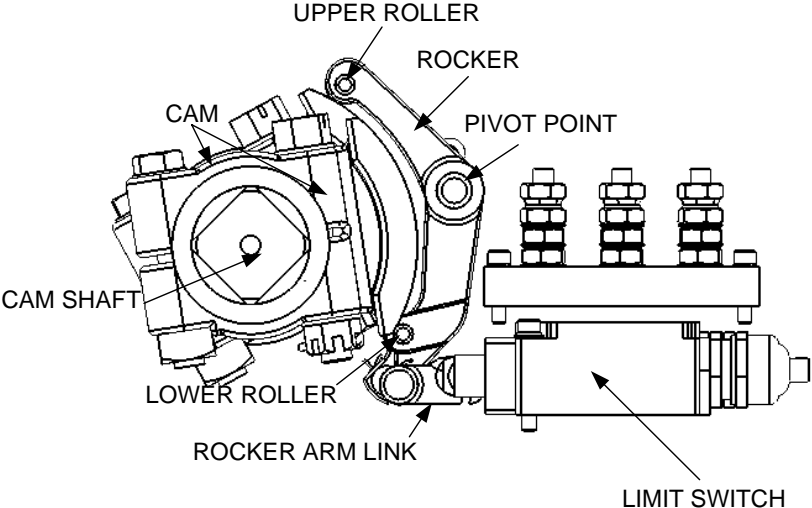
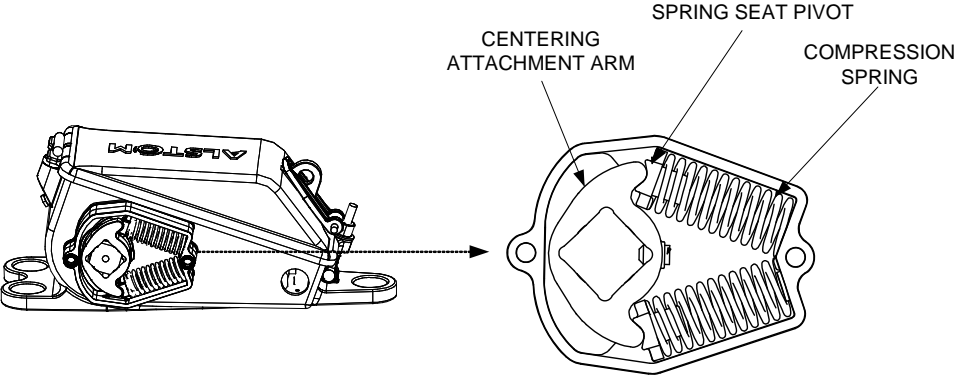
NOTE

If the verification procedure determines faulty components other than those covered in Section 6, “Corrective Maintenance,” replace the entire controller.

Table 4–4. Verification Procedure– 7R Controller and Layout

Step	Procedure	Corrective Action
1	Verify the screws, nuts, and bolts are tight.	Tighten all screws, nuts, and bolts. Torque cam clamping screws to 15 pounds-feet.
2	Verify the hinges, latch and padlock are undamaged. Tension of cover latch must be enough to make the cover close tightly.	If hinges, latch, or padlock are damaged, replace as necessary.
3	Inspect inside of the case for the presence of water and debris.	<p>If water or debris is found inside controller case, clean or replace ventilator and dry inside of case. Lubricate in accordance with procedure in this section (Table 4–3).</p> <p style="text-align: center;"><u>NOTE</u></p> <p>Two drain holes are located on the bottom of the case. One is below the rockers and the second is in the wire entrance area. The holes are tapped and may be plugged with #8-32 screws.</p>
<p><u>WARNING</u></p> <p>IF THE 7R CONTROLLER HAS BEEN FLOODED OR TEMPORARILY SUBMERGED IN WATER, THE CONTROLLER MUST BE THOROUGHLY CLEANED AND INSPECTED. COVERS MUST BE REMOVED FROM THE LIMIT SWITCHES TO CONFIRM THERE IS NO EVIDENCE OF WATER ENTERING. IF A LIMIT SWITCH CONTAINS EVIDENCE OF WATER ENTERING, IT MUST BE REPLACED.</p> <p>LUBRICATE THE 7R CONTROLLER BEFORE RETURNING IT TO SERVICE.</p>		

Table 4–4. Verification Procedure (Cont.)

Step	Procedure	Corrective Action
4	Verify that the cover, base, and terminal board are undamaged. Gaskets are in place and undamaged.	If cover, base, terminal board, or gaskets are damaged, replace as necessary.
5	Verify the internal pins and cotters are in place and secure.	If internal pins or cotters are missing or broken, replace missing/faulty part and secure.
6	Inspect the rod, crank arm, and shaft for excessive lost motion (slop).	If rod, crank arm, or shaft has excessive lost motion (slop), tighten securing hardware.
7	Verify the rollers move freely and have no flat spots. Rollers must rotate when in contact with cam. Rollers must be centered (widthwise) on cam face. Lubricate rollers at their axle shafts.	Tighten or replace as necessary. If contact assembly rollers, pins, or bearings require lubrication, apply oil in accordance with Table 4–3.
8	Verify the rail connections are secure (for shunt applications).	If rail connections are not tight, tighten securing hardware.
9	Verify the centering attachment is operating properly.	Tighten or replace as necessary.
10	Verify that all wire terminals are tight. Visually inspect all wire terminations and check for any broken strands of wire. Visually inspect that all wiring insulation is not chafed. Verify that wiring is properly dressed and tied to prevent damage from vibration.	Tighten nuts at terminal posts as necessary. Replace wire terminals with original equipment manufacturer (OEM) terminals as necessary. Replace wiring if chafed.
11	Every 90 days verify proper operation of each pair of limit switch contacts. Refer to the approved application circuit. Use an Ohm meter to independently verify performance of every pair of contacts that open to remove indication will open with an obstruction in the points in accordance with customer or authority or governing FRA rules (if applicable). (Continued on next page.)	(See next page.)

Table 4–4. Verification Procedure (Cont.)

Step	Procedure	Corrective Action
11 (Cont.)	Similarly, use an Ohm meter to independently verify performance of every pair of contacts that close to provide shunting will provide shunting in accordance with customer or authority or governing FRA rules (if applicable).	<p>If switch contacts do not open or close as required, <u>or</u> if the contacts have high resistance, first verify that the switch circuit is wired properly and terminations are tight.</p> <p>If the 7R controller is wired correctly and switch contacts do not perform properly, follow Table 3–4. Example Field Indication Adjustment Procedure for the cam associated with the incorrectly performing switch. Verify that the cam is slightly out of adjustment and readjust the cam.</p> <p>If switch contacts do not perform properly after readjustment, replace the switch.</p>

4.6. CENTERING ATTACHMENT CHECK

The Centering Attachment Check Procedure consists of a spring pressure check and an optional spring replacement procedure. Perform the pressure check portion of the procedure provided in Table 4–5 at least once a year. Perform the replacement part of the procedure as required.

WARNING

IF POINTS WERE THROWN, HEED THE FOLLOWING:
BEFORE ATTEMPTING PREVENTIVE OR CORRECTIVE MAINTENANCE ON THE CONTROLLER, ENSURE THAT ALL MECHANICAL LINKAGES HAVE BEEN DISCONNECTED. DISCONNECT LINKAGES WITH CRANK ARM VERTICAL. FAILURE TO DO SO MAY RESULT IN DAMAGE TO THE EQUIPMENT AND PERSONAL INJURY.

Table 4–5. Centering Attachment Check Procedure

Step	Procedure
1	Move switch points to mid-stroke position and verify controller shaft is vertical.
2	Disconnect link to operating arm of switch circuit controller.
3	With the spring force gauge on ball of operating arm and being pulled perpendicular to arm, confirm a reading of 15 lb or more in both directions of arm motion.
4	If a reading of 15 lb is obtained, this procedure is complete. If a reading of 15 lb cannot be attained, continue this procedure.
5	<p>Remove two screws in cover of centering attachment and remove cover. Verify that the springs are intact and not broken or corroded. Replace any broken or corroded springs.</p> <p style="text-align: center;"><u>WARNING</u></p> <p style="text-align: center;">CONTROLLER SPRINGS ARE COMPRESSED WHEN THE CONTROLLER SHAFT IS IN THE NEUTRAL POSITION. USE CARE IN CONTROLLING THE SPRINGS WHEN REPLACING THEM TO AVOID PERSONAL INJURY.</p> <p>Corrosion of springs is an indication of a gasket failure. Inspect gaskets between centering attachment and case and between cover and centering attachment. Replace gaskets if necessary.</p>
6	Replace attachment cover and two screws.
7	Use the spring force gauge to confirm 15 lb reading on replaced springs.
8	Reconnect link to operating arm of switch circuit controller.

5. SECTION 5 – TROUBLESHOOTING

5.1. GENERAL PHILOSOPHY

This section discusses troubleshooting Alstom Model 7R Switch Circuit Controllers.

Procedures for limit switch removal and replacement and the controller obstruction test are found in Section 6, Corrective Maintenance.

5.2. TROUBLESHOOTING

When a controller is not functioning properly during normal use:

- Perform preventive maintenance procedures
- Verify external power connections
- Verify wiring

Damaged and faulty components can be identified during routine maintenance. Follow the corrective steps included or referenced in the preventive maintenance procedures provided in Section 4.

Refer to the location Book Of Plans (BOP) to verify all external power connections and wiring.

THIS PAGE INTENTIONALLY LEFT BLANK.

6. SECTION 6 – CORRECTIVE MAINTENANCE

6.1. GENERAL PURPOSE

This section describes how to perform field or shop corrective maintenance on the Alstom Model 7R Switch Circuit Controllers. The procedures for limit switch removal and replacement, the controller obstruction test, and spare parts are found in this section.

6.2. REQUIRED TEST EQUIPMENT

The materials the maintainer needs to perform corrective maintenance the Alstom Model 7R controllers are provided in Table 6–1.

Table 6–1. Corrective Maintenance Equipment

Equipment	Manufacturer/Model
Ohm Meter	Any
Obstruction Gauge	Any
Oil: Low Temperature Mineral Base Oil	Alstom 91A0007 (P/N 81379-005-08) or Equivalent

See Section 7 for assembly drawings and parts lists.

6.3. REMOVAL AND REPLACEMENT PROCEDURES

Corrective maintenance for Alstom Model 7 Switch Circuit Controllers is limited to the removal and replacement of the limit switches. This section presents the necessary removal and replacement procedures.

WARNING

IF CENTERING ATTACHMENT IS PRESENT OR POINTS WERE THROWN, HEED THE FOLLOWING:

BEFORE ATTEMPTING PREVENTIVE OR CORRECTIVE MAINTENANCE ON THE CONTROLLER, ENSURE THAT ALL MECHANICAL LINKAGES HAVE BEEN DISCONNECTED. DISCONNECT LINKAGES WITH CRANK ARM VERTICAL. FAILURE TO DO SO MAY RESULT IN DAMAGE TO THE EQUIPMENT AND PERSONAL INJURY.

WARNING

DISCONNECT MOTOR ENERGY WHENEVER MAKING ADJUSTMENTS TO THE SWITCH LAYOUT OR SWITCH MACHINE. UNEXPECTED OPERATION OF THE MACHINE COULD CAUSE INJURY FROM OPEN GEARS, ELECTRICAL SHOCK, OR MOVING PARTS.

6.3.1. Limit Switch Removal and Replacement

To remove and replace a limit switch from a Model 7R controller, follow the procedure provided in Table 6–2.

WARNING

DISCONNECT MOTOR ENERGY WHENEVER REPLACING COMPONENTS OR MAKING ADJUSTMENTS TO THE SWITCH LAYOUT OR SWITCH MACHINE. UNEXPECTED OPERATION OF THE MACHINE COULD CAUSE INJURY FROM OPEN GEARS, ELECTRICAL SHOCK, OR MOVING PARTS.

Table 6–2. Limit Switch Removal and Replacement Procedure

Step	Procedure
1	Disengage latch and open cover.
2	Remove 4 hex socket head cap screws connecting the terminal block to the frame. <div style="text-align: center; margin-top: 10px;">  <p>Hex Socket Head Cap Screws (4)</p> </div>
3	Gently lift out the terminal block, being careful not to bend or twist the wiring.

Table 6–2. Limit Switch Removal and Replacement Procedure (Cont.)

Step	Procedure
4	<p>Remove 2 hex socket head cap screws connecting the limit switch to be removed from the frame.</p> 
5	Disconnect wiring from limit switch to be removed.
6	Tip limit switch to disengage the switch from the rocker arm link and remove.
7	Connect wiring to the new limit switch.
8	<p>Place the new limit switch in position, aligning the limit switch with the rocker arm link.</p> 

Table 6–2. Limit Switch Removal and Replacement Procedure (Cont.)

Step	Procedure
9	Install and tighten 2 hex socket head cap screws to hold the limit switch in position.
10	Rotate camshaft so that cam opens the normally closed contacts and closes the normally open contacts.
11	Use an Ohm meter to verify that the normally open contacts are closed and that the normally closed contacts are open. If any contact does not respond as above, loosen the 2 hex socket head cap screws on the switch and adjust it until the normally open contact closes (or the normally closed contact opens), then retighten the screws.
12	Manually shake the controller arm and verify that contact is not lost (the normally open contacts must remain closed). If contact is lost, go back to Step 8.
13	Rotate camshaft so that cam allows the normally closed contacts to close and the normally open contacts to open.
14	Use an Ohm meter to verify the normally closed contacts are closed and the normally open contacts are open. If any contact does not respond as above, loosen the 2 hex socket head cap screws on the switch and adjust it until the normally open contact opens (or the normally closed contact closes), then retighten the screws. If adjustment was required, go back to Step 8.
15	Manually shake the controller arm and verify that contact is not lost (the normally closed contacts must remain closed). If contact is lost, go back to Step 13.
16	Reinstall the terminal block, tightening down the 4 hex socket head cap screws connecting the terminal block to the frame.
17	Close cover and secure latch.
18	Conduct obstruction test provided in Table 6–3 to verify controller operation.

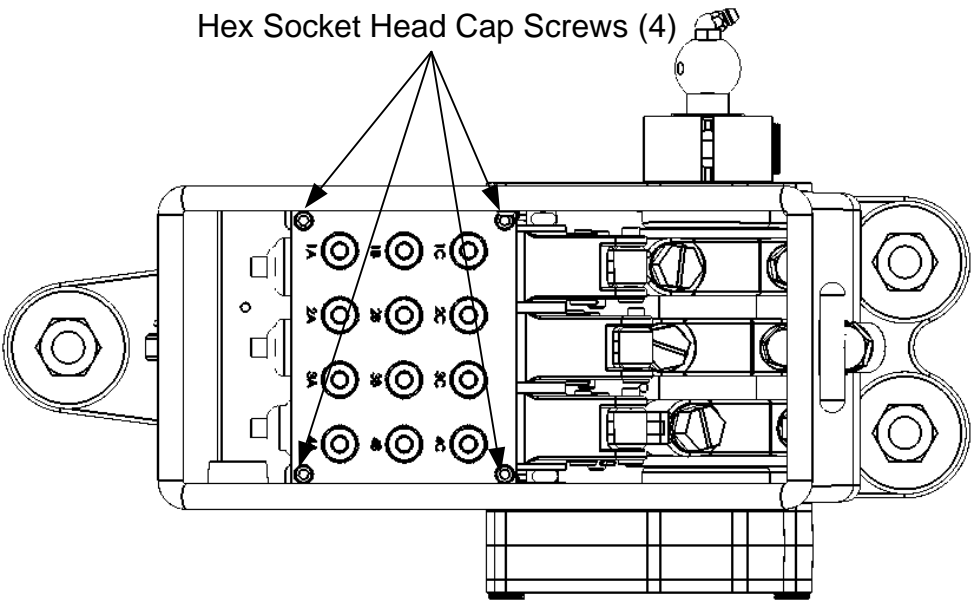
6.4. OBSTRUCTION TEST

An obstruction test is to be conducted following corrective maintenance to verify the overall operation of the controller. Due to the diversity of applications in which the controller can be used, the test procedure in Table 6–3 is necessarily generic. To conduct the obstruction test, follow the procedure provided in Table 6–3.

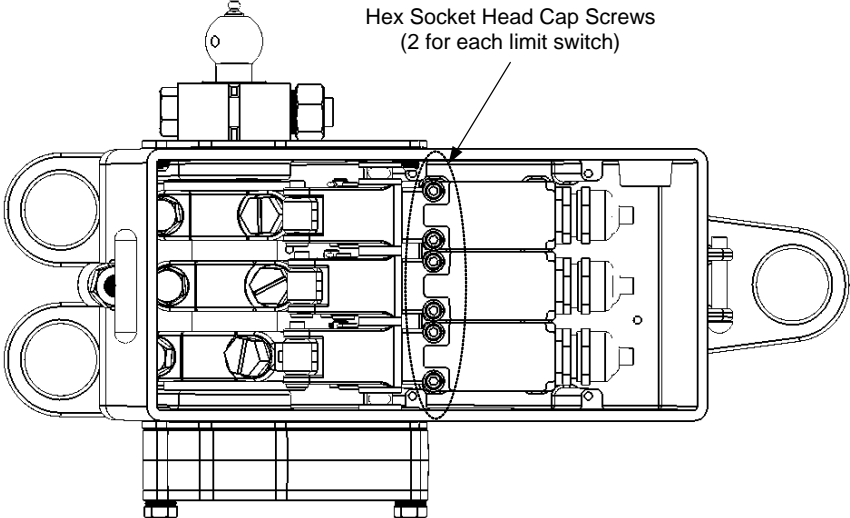
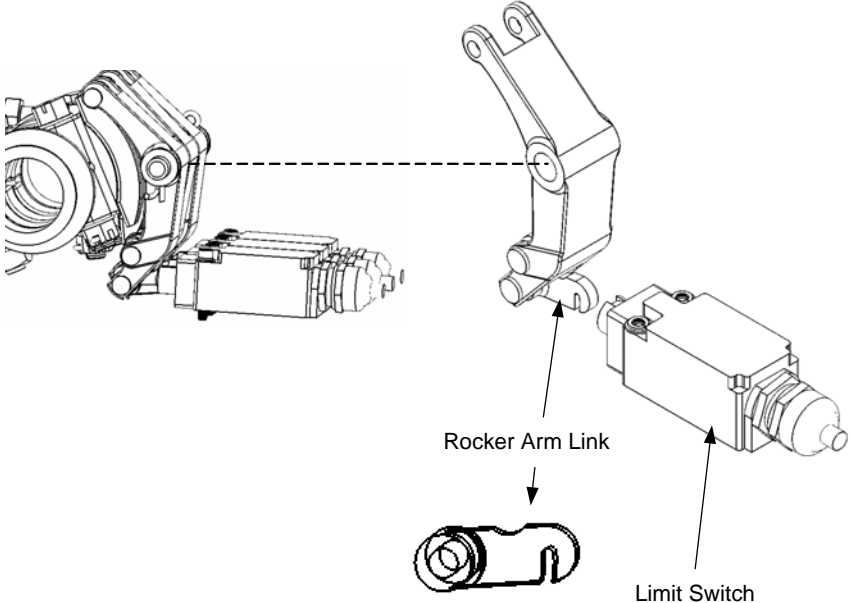
WARNING

RAILROADS, AUTHORITIES, AND OTHER USERS OF THE 7R CONTROLLER USUALLY HAVE APPROVED PROCEDURES FOR OBSTRUCTION TESTING. THESE APPROVED PROCEDURES OR OTHER GOVERNING RULES, SUCH AS FRA, SHALL BE ADHERED TO AS REQUIRED BY THE RAILROAD, AUTHORITY, OR GOVERNING BODY.

WARNING

DISCONNECT MOTOR ENERGY WHENEVER WORKING ON THE SWITCH LAYOUT OR SWITCH MACHINE. UNEXPECTED OPERATION OF THE MACHINE COULD CAUSE INJURY FROM OPEN GEAR, ELECTRICAL SHOCK, OR MOVING SWITCH POINTS.

Table 6–3. Obstruction Test Procedure

Step	Procedure
1	With controller installed, mechanical and electrical connections made, and cam roller adjusted, obstruct the operation of device being monitored. <p style="text-align: center;"><u>NOTE</u></p> For example, place an obstruction gauge between switch points and stock rail.
2	Operate monitored device.
3	Check for correct indication.
4	If correct indication is observed, remove the obstruction gauge and configure system for normal operation. If correct indication is not observed, follow Table 4–4. Verification Procedure–7R Controller and Layout. Then repeat Steps 1 through 3 above.
5	If correct indication is observed, remove obstruction gauge and configure system for normal operation. If correct indication is not observed, replace the controller.

7. SECTION 7 – PARTS CATALOG

7.1. GENERAL

This section contains the illustrated parts lists for the Alstom Model 7R Switch Circuit Controllers. The information in this section includes:

- Illustrations of the Model 7R controller and the Centering Attachment
- Parts Lists referenced to the illustrations

7.2. PARTS LISTS AND DRAWINGS

Note that each illustrated parts list contains the component reference number, name, and drawing number. Use the Alstom drawing number for ordering repair/replacement parts.

7.2.1. Model 7R Switch Circuit Controller

NOTE

Switch leads are assembled to terminal posts per the drawing provided in Figure A–2. The as shipped wiring configuration is per circuit P/N 48950-311-00. This circuit is for monitoring both normal and reverse point positions when one 7R Controller is used and installed on the normal point side, and a front rod assembly is connected between the point rails. For other application circuits for this product, see Appendix A. For example:

Circuit 48950-310-00 - For use when monitoring the normal point only when one 7R Controller is installed on the normal point side and no front rod assembly is connected between the point rails. See Figure A–1.

Circuit 48950-312-00 - For use when monitoring both the normal and reverse point positions when two 7R Controllers are installed and no front rod assembly is connected between the point rails. See Figure A–3.

Circuit 48950-313-00 - For use when monitoring the normal points only in a crossover when one 7R Controller is installed on the normal point of each switch and no front rod assemblies are connected between the point rails. See Figure A–4.

WARNING

ANY DEVIATION FROM THE WIRING CIRCUITS PROVIDED IN APPENDIX A MUST BE APPROVED BY AN ALSTOM SAFETY OFFICER.

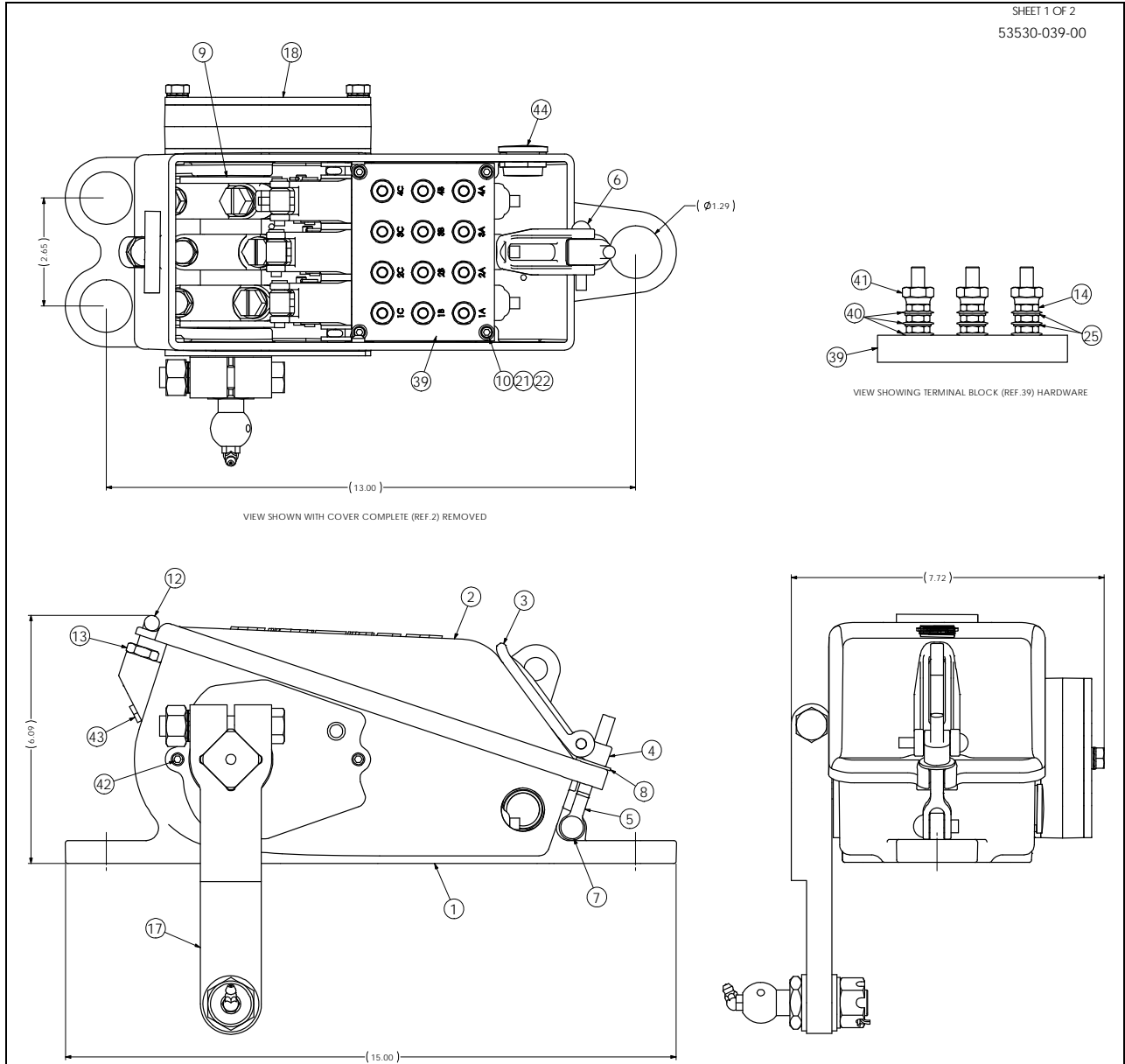
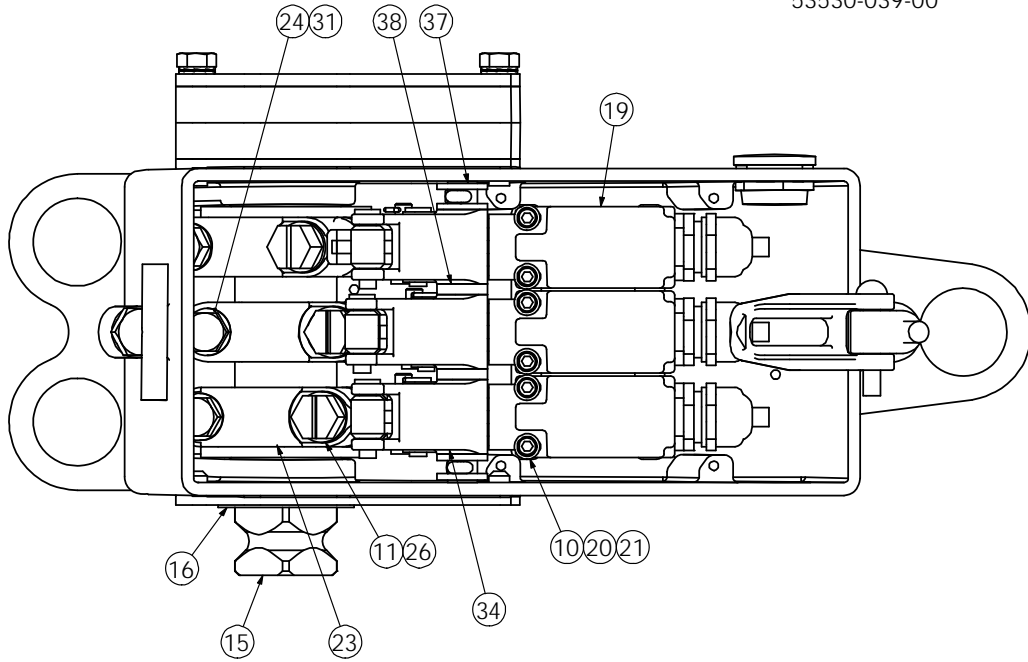
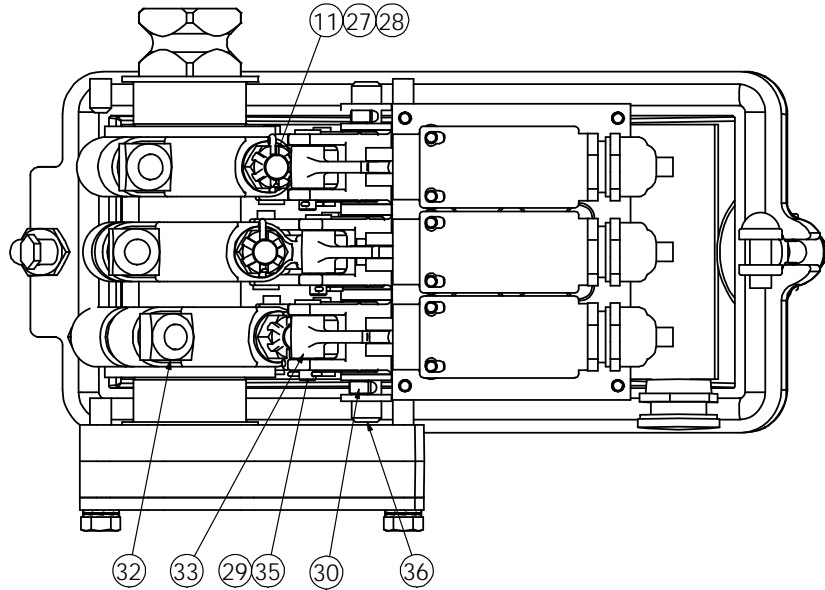

Figure 7-1. Model 7R Switch Circuit Controller P/N 53530-039-00

SHEET 2 OF 2
53530-039-00



VIEW SHOWN WITH COVER COMPLETE (REF.2)
AND CRANK COMPLETE (REF.18) REMOVED



BOTTOM VIEW SHOWN WITH CASE (REF.1)
AND CRANK COMPLETE (REF.18) REMOVED

Figure 7-1. Model 7R Switch Circuit Controller P/N 53530-039-00 (Cont.)

Table 7-1. Model 7R Switch Circuit Controller P/N 53530-039-01 Parts List

Ref.	Description	Drawing No.
1	Case, 7R Switch Box	38652-048-00
2	Cover Complete, 7R Switch Box	38639-009-01
3	Handle, 7R Switch Box Cover	35497-004-00
4	Nut, 5/16-18 Special	18669-018-00
5	Jaw, Turnbuckle Fitting	32125-025-00
6	Rivet, .250 Dia x 1.500 Lg Button Hd	00114-000-ON
7	Rivet, .313 x .88 Lg Button Hd	00791-004-ON
8	Washer, .344 ID, .875 OD, .063 Thk Flat	01250-014-ON
9	Washer, 1.52 ID, 2.50 OD, .156 Thk Flat	00626-104-00
10	Washer, .172 ID, .375 OD, .031 Thk Flat	01250-006-ON
11	Washer, .406 ID, .750 OD, .063 Thk Flat	01250-016-ON
12	Bolt, 3/8-16 x 1 1/2 Lg T	GMV00-005-00
13	Nut, 3/8-16 x 15/64 Thk Hex Jam	37539-001-00
14	Nut, #10-24 x .130 Thk Hex	01272-006-ON
15	Shaft, Cam	38651-018-00
16	Sleeve, Bearing	00585-076-00
17	Crank Complete, 7R Circuit Controller	38660-030-00
18	Centering Attachment, 7R Circuit Controller	53231-003-01
19	Switch Complete, Limit	35931-004-01
20	Screw, #8-32 x 3/4 Lg Socket Hd Cap	17708-177-00
21	Washer, .167 ID, .293 OD, .040 Thk Lock	01273-022-ON
22	Screw, #8-32 x 7/8 Lg Socket Hd Cap	17708-186-00
23	Cam, Switch Box	38654-030-00
24	Washer, .384 ID, .692 OD, .040 Thk Shk'prf	53029-077-00
25	Washer, .256 ID, .478 OD, .028 Thk Shk'prf	53029-075-00
26	Bolt, 3/8-10 x 2 3/4 Lg Hex Hd W/Cot Hole	51596-007-00
27	Nut, 3/8-10 x 3/8 Thk Slotted Hex	00293-004-ON
28	Pin, Cotter, 3/32 Dia x 5/8 Lg	00035-001-ON
29	Pin, Cotter, 1/16 Dia x 1/2 Lg	00563-002-ON
30	Pin, Cotter, 3/16 Dia x 3/4 Lg	00808-001-00

Table 7–1. Model 7R Switch Circuit Controller P/N 53530-039-01 Parts List (Cont.)

Ref.	Description	Drawing No.
31	Screw, 3/8-16 x 2 1/2 Lg Hex Hd Cap	00280-001-ON
32	Nut, 3/8-16 x 3/8 Thk Sq	00689-009-ON
33	Link, Rocker Arm	35505-044-00
34	Rocker Arm Complete, Switch Box	35465-000-02
35	Pin, .250 x 1.13 Lg	00730-040-00
36	Shaft, Rocker	35499-004-00
37	Spacer, .453 ID, .750 OD, .094 Thk	35462-001-00
38	Spacer, .453 ID, .750 OD, .156 Thk	35462-002-00
39	Block, Terminal, 12 Way	47508-238-00
40	Washer, .265 ID, .563 OD, .040 Thk Flat	01225-002-00
41	Nut, #14-24 x 5/16 Thk Hex AAR	42843-001-00
42	Screw, 5/16-18 x 1/2 Lg Skt Set-Cup Point	17708-185-00
43	Ventilator, 1/16 NPT	49915-008-00
44	Plug	56781-033-00

7.2.2. Model 7R Switch Circuit Controller Centering Attachment

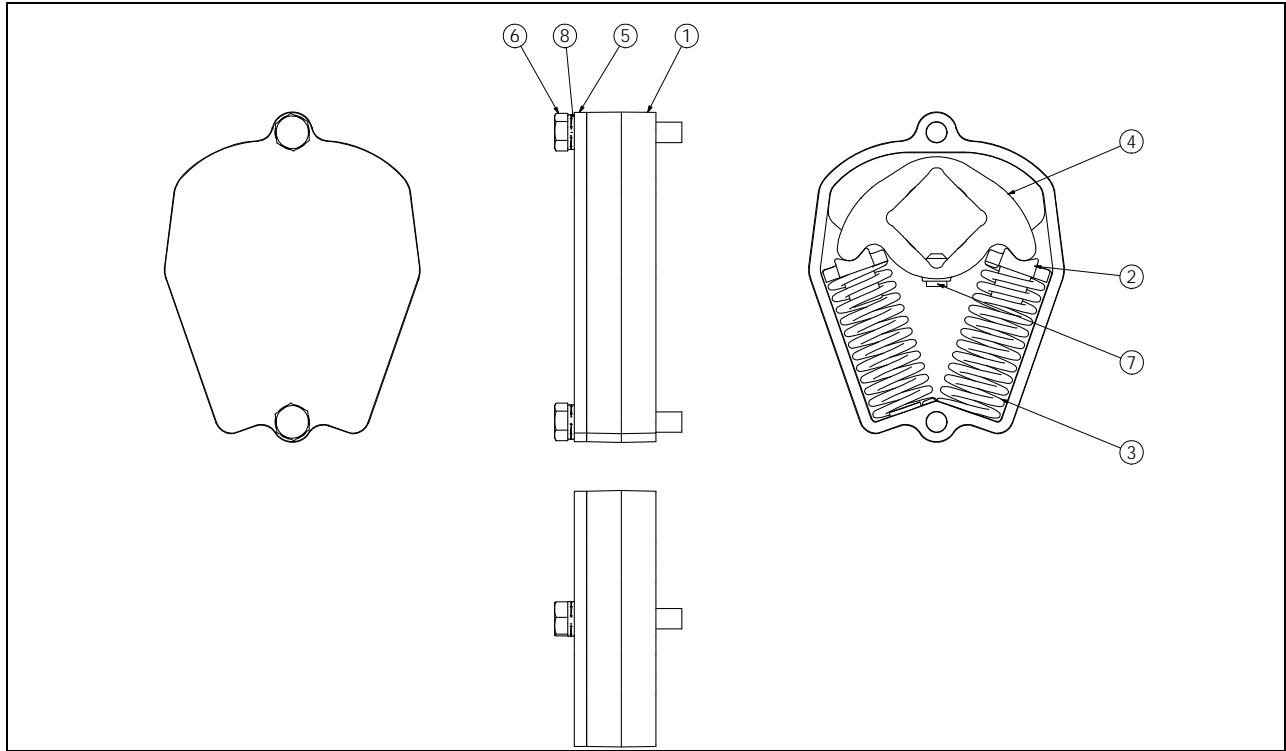

Figure 7–2. Centering Attachment P/N 53231-003-01

Table 7–2. Centering Attachment P/N 53231-003-01 Parts List

Ref.	Description	Drawing No.
1	Case, Centering Attachment	53683-005-00
2	Pivot, Spring Seat	53867-002-00
3	Spring, Compression 1.00OD, 3.50 Lg	00786-401-00
4	Arm, Centering Attachment	53685-002-00
5	Cover, Centering Attachment	53684-004-00
6	Screw, 5/16-24x1 3/4 Lg Hex Hd Cap	03440-029-00
7	Screw 5/16-24x1/2Lg Skt Set-Cup Point	17708-183-00
8	Washers, 5/16 Nord-Lock (Pair)	02400-010-00

7.2.3. Model 7R Switch Circuit Controller Crank

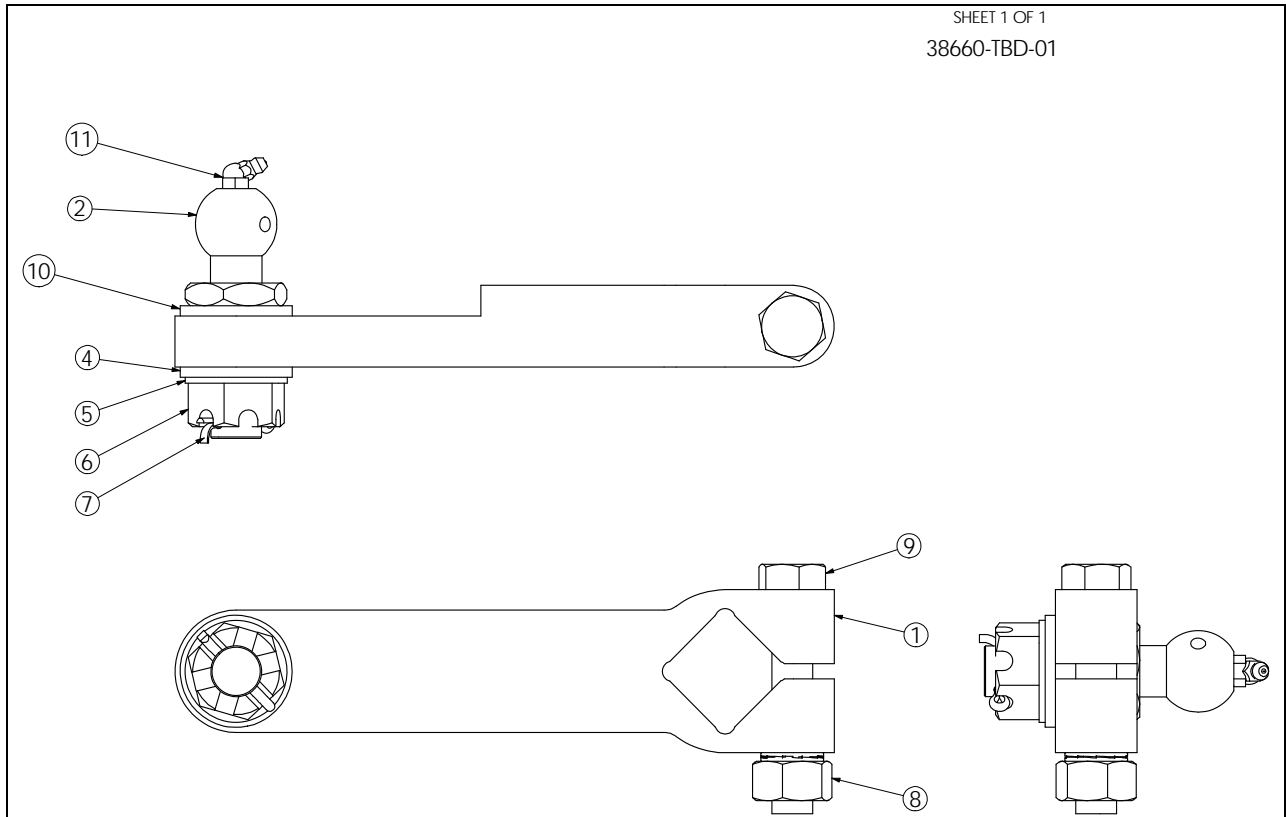

Figure 7-3. Crank P/N 38660-030-00

Table 7-3. Crank P/N 38660-030-00 Parts List

Ref.	Description	Drawing No.
1	Crank, 6.00 Center	38661-064-00
2	Pin, Ball	43206-006-00
3	Bushing, .625 ID, .804 OD, .844 Lg	43207-002-00
4	Washer, .813 ID, 1.375 OD, .125 Thk Fiber	43208-001-00
5	Washer, .641 ID, 1.250 OD, .07 Thk Flat	43209-000-00
6	Nut, 5/8-11 x 39/64 Thk Slotted Hex	50748-005-00
7	Pin, Cotter, .125 Dia x 1.00 Lg	00040-003-ON
8	Nut, 1/2-13 x 7/16 Thk Hex	01048-006-00
9	Screw, 1/2-13 x 2 3/4 Lg Hex Hd	03343-027-00
10	Washer, 1/2 Nord-Lock (pair)	02400-016-00
11	Fitting, Grease, .188 Drive 65° Elbow	34232-024-00

THIS PAGE INTENTIONALLY LEFT BLANK.

A. APPENDIX A – CIRCUIT DRAWINGS

A.1. GENERAL

This section contains example wiring diagrams from typical Model 7R applications.

Each 7R Controller must be wired according to an approved configuration provided in this Appendix.

WARNING

ANY DEVIATION FROM THE WIRING CIRCUITS PROVIDED IN APPENDIX A MUST BE APPROVED BY AN ALSTOM SAFETY OFFICER.

THIS PAGE INTENTIONALLY LEFT BLANK.

7R Switch Circuit Controller
Circuit 48950-310-00

Note 1: This circuit checks the Normal point position only at all times. One 7R Controller is connected to the normal switch point. When the normal switch point opens ¼" the bias neutral indication relay is shunted.

Note 2: Contacts #21 and #22 are Positive Break Normally Closed, Contacts #13 and #14 are Normally Open.

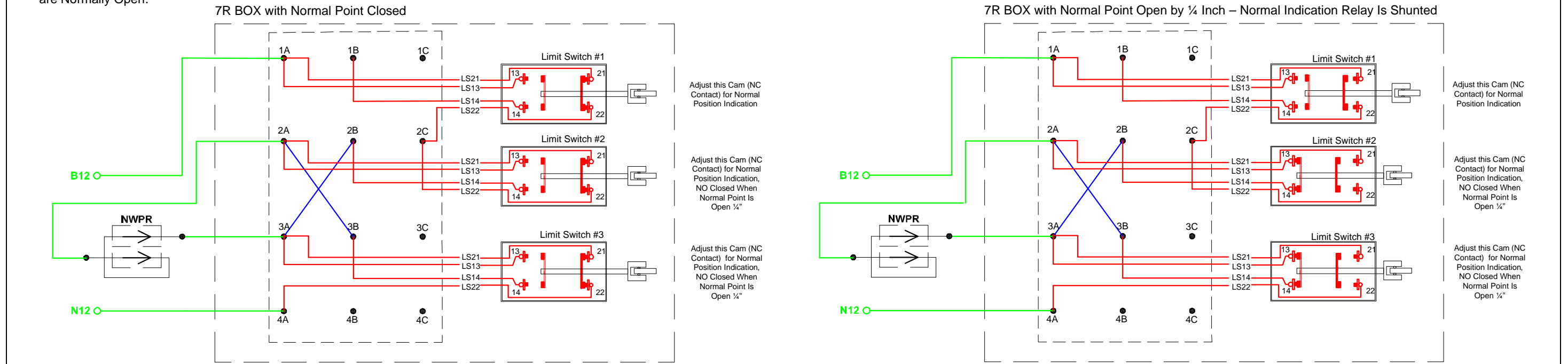

Figure A-1. 7R Switch Circuit Controller Circuit 48950-310-00

7R Switch Circuit Controller
Circuit 48950-311-00, Sheet 1

Note 1: This circuit checks the Normal and Reverse switch indication when one 7R Controller is used and connected to the normal switch point and the normal and reverse points are connected with a front rod assembly.
 When the normal switch point opens 1/4" the normal bias neutral indication relay is shunted. When reverse point opens 1/4" the reverse bias neutral indication relay is shunted.

Note 2: Contacts #21 and #22 are Positive Break Normally Closed, Contacts #13 and #14 are Normally Open.

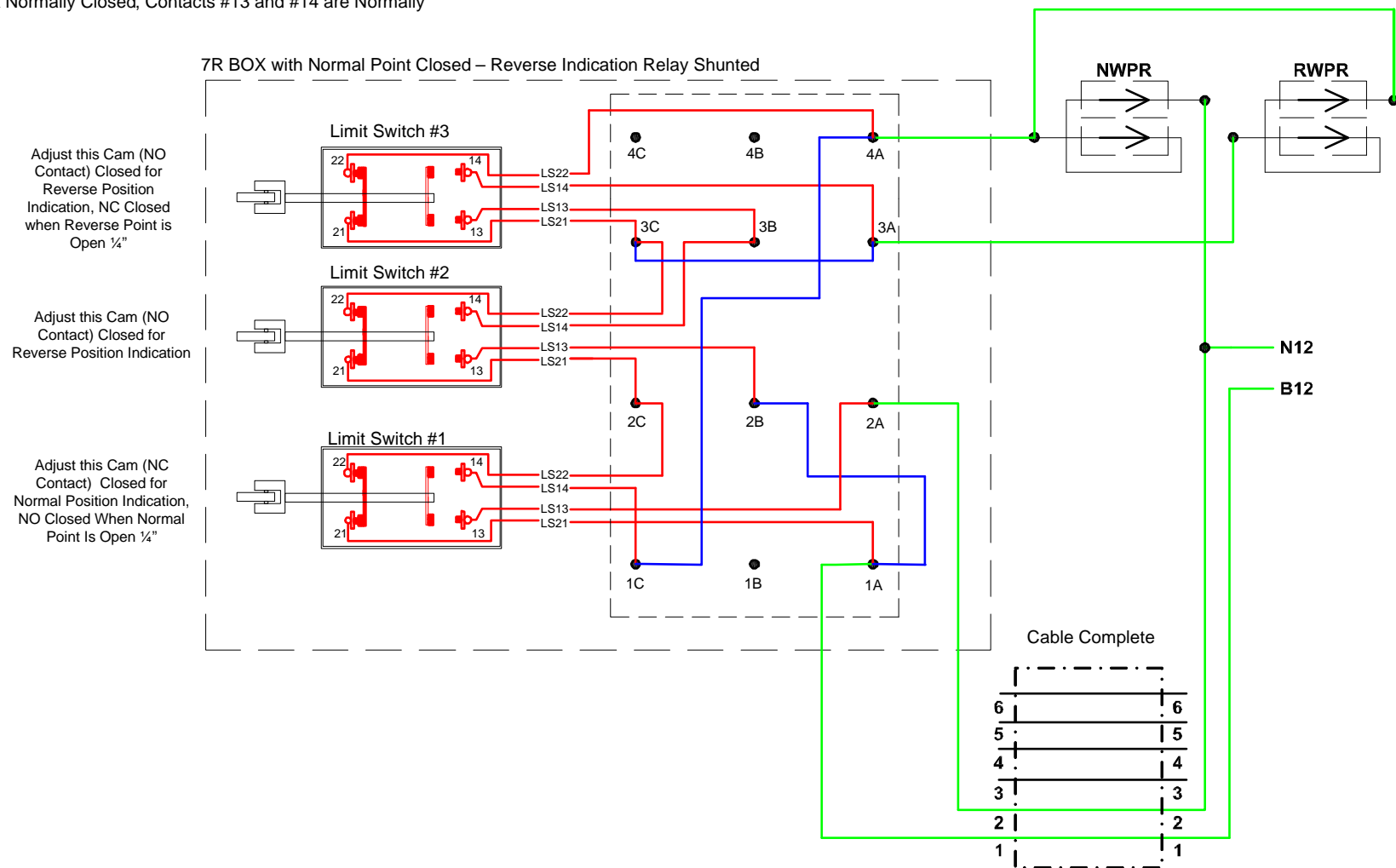

Figure A-2. 7R Switch Circuit Controller Circuit 48950-311-00

7R Switch Circuit Controller
Circuit 48950-311-00, Sheet 2

Note 1: This circuit checks the Normal and Reverse switch indication when one 7R Controller is used and connected to the normal switch point and the normal and reverse points are connected with a front rod assembly.
When the normal switch point opens 1/4" the normal bias neutral indication relay is shunted. When reverse point opens 1/4" the reverse bias neutral indication relay is shunted.

Note 2: Contacts #21 and #22 are Positive Break Normally Closed, Contacts #13 and #14 are Normally Open.

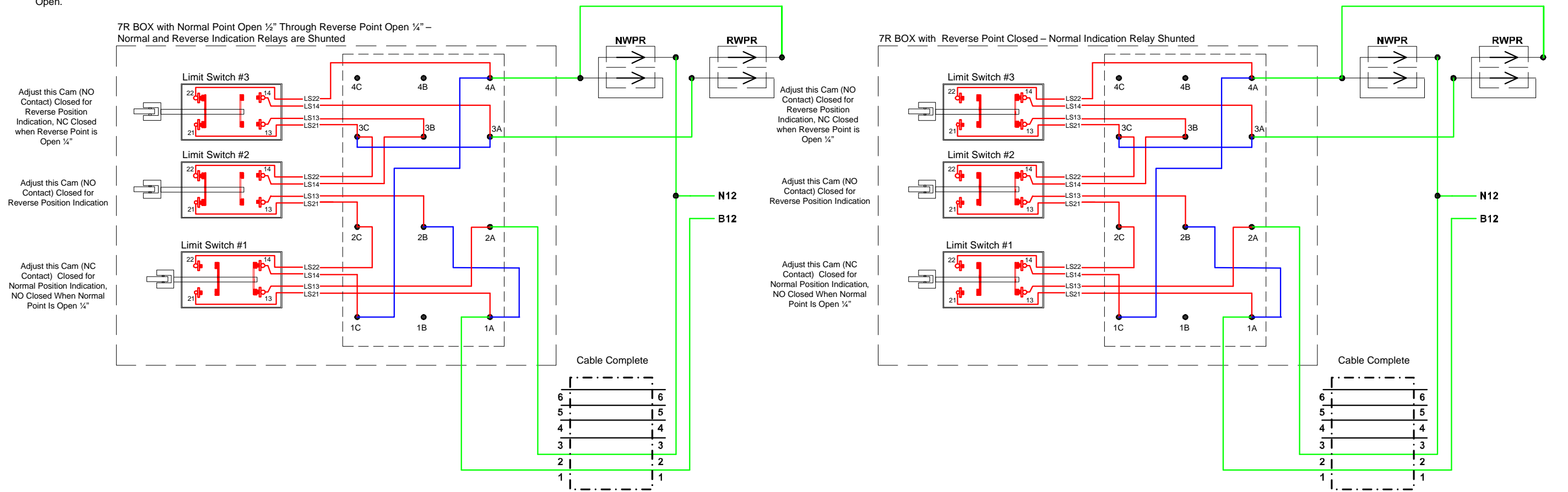

Figure A-2. 7R Switch Circuit Controller Circuit 48950-311-00 (Cont.)

7R Switch Circuit Controller
Circuit 48950-312-00, Sheet 1

Note 1: This wiring includes shunts and monitors both the Normal and Reverse point positions at all times with two 7R Controllers.
When the normal switch point opens ¼" the normal bias neutral indication relay is shunted.
When reverse point opens ¼" the reverse bias neutral indication relay is shunted.

Note 2: Contacts #21 and #22 are Positive Break Normally Closed, Contacts #13 and #14 are Normally Open.

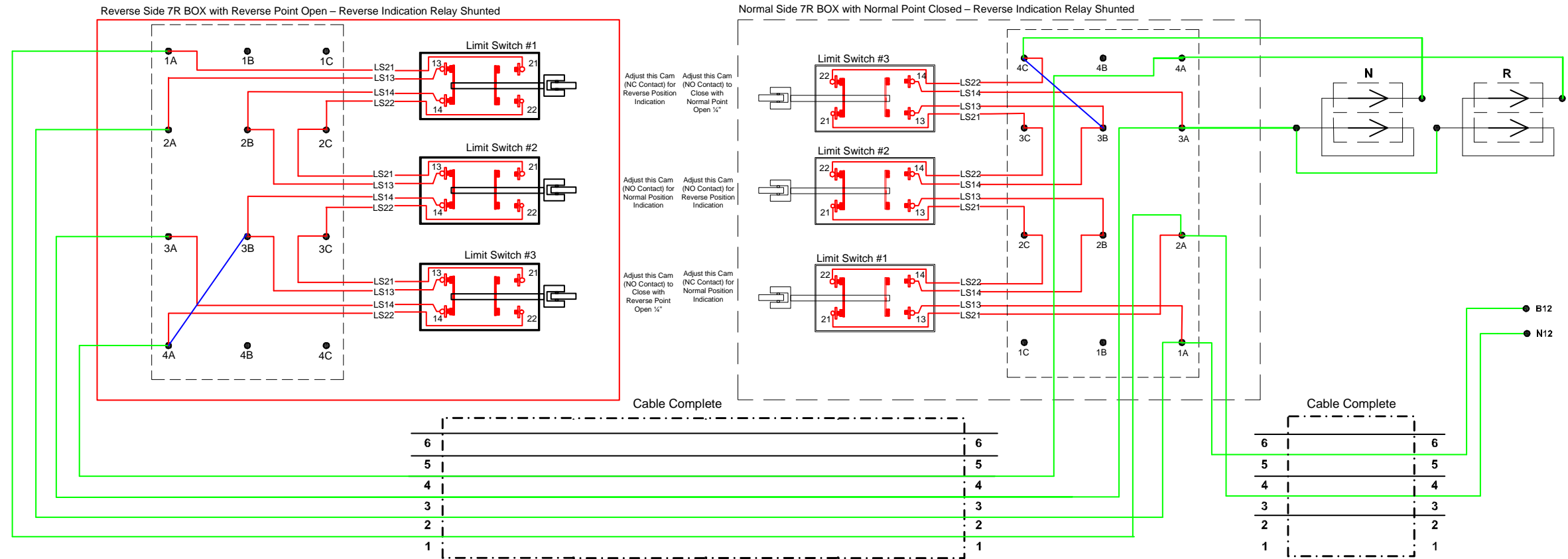

Figure A-3. 7R Switch Circuit Controller Circuit 48950-312-00

7R Switch Circuit Controller
Circuit 48950-312-00, Sheet 2

Note 1: This wiring includes shunts and monitors both the Normal and Reverse point positions at all times with two 7R Controllers.
When the normal switch point opens 1/4" the normal bias neutral indication relay is shunted.
When reverse point opens 1/4" the reverse bias neutral indication relay is shunted.

Note 2: Contacts #21 and #22 are Positive Break Normally Closed, Contacts #13 and #14 are Normally Open.

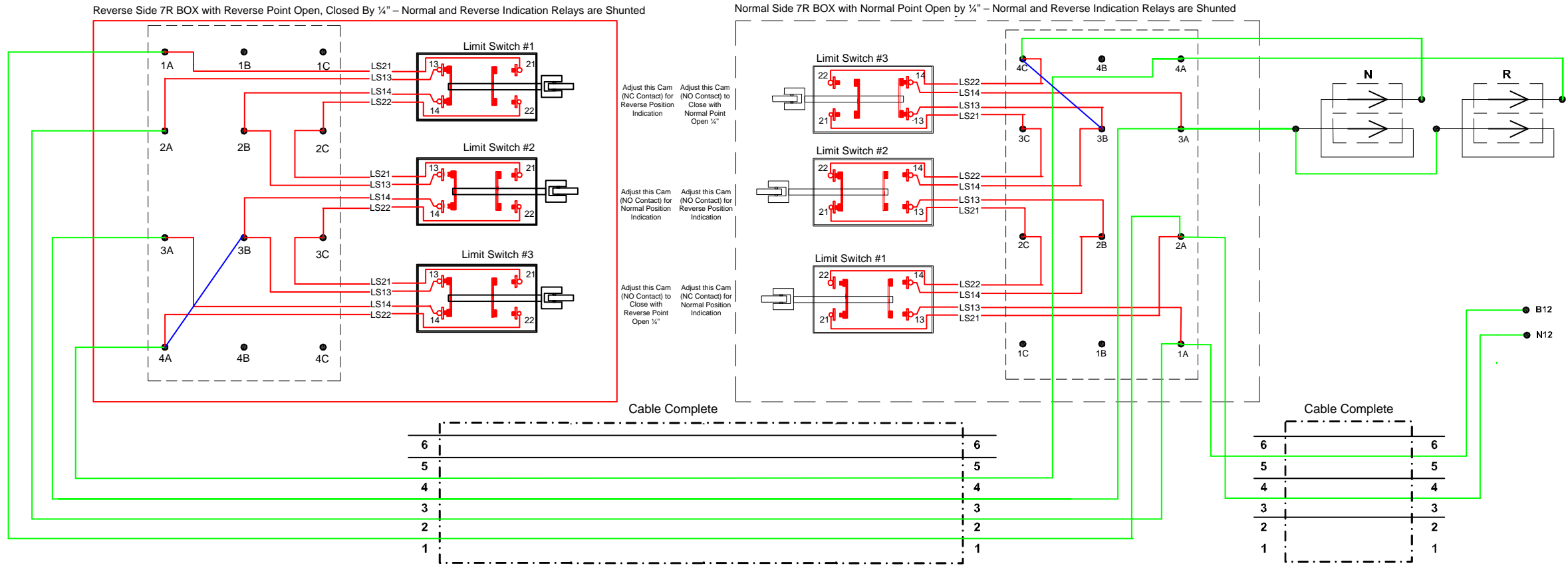

Figure A-3. 7R Switch Circuit Controller Circuit 48950-312-00 (Cont.)

7R Switch Circuit Controller
Circuit 48950-312-00, Sheet 3

Note 1: This wiring includes shunts and monitors both the Normal and Reverse point positions at all times with two 7R Controllers.
When the normal switch point opens 1/4" the normal bias neutral indication relay is shunted.
When reverse point opens 1/4" the reverse bias neutral indication relay is shunted.

Note 2: Contacts #21 and #22 are Positive Break Normally Closed, Contacts #13 and #14 are Normally Open.

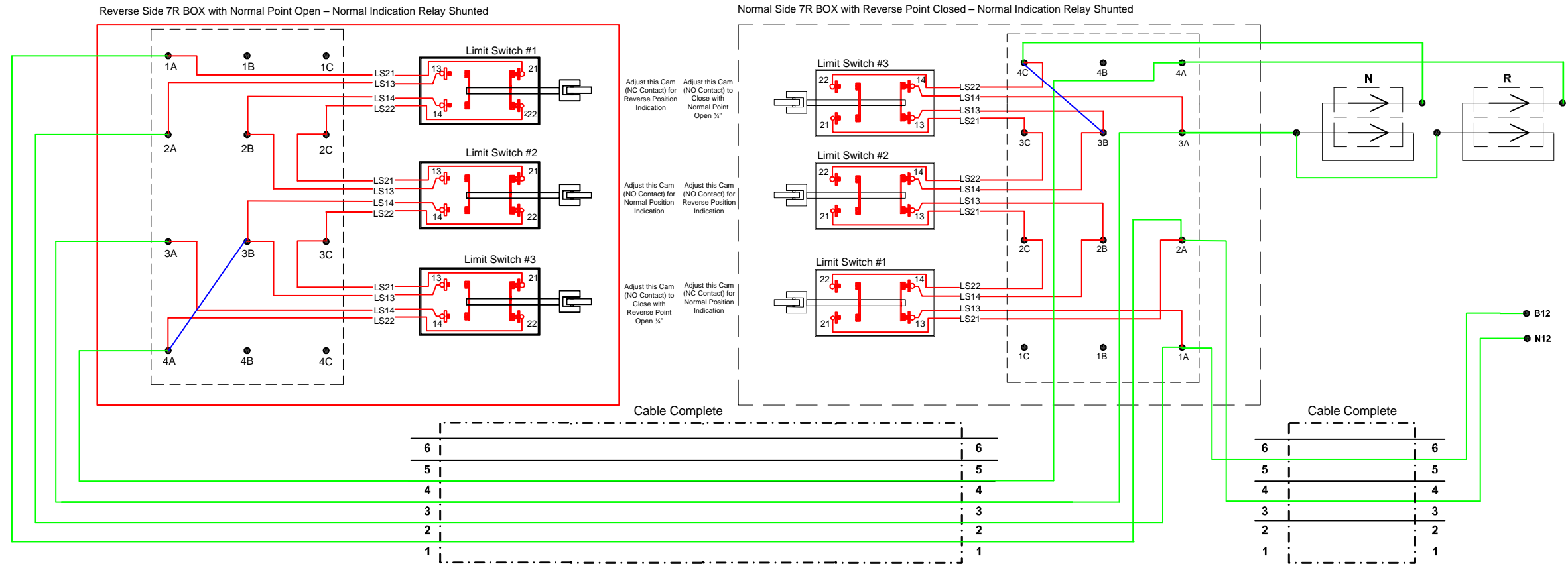

Figure A-3. 7R Switch Circuit Controller Circuit 48950-312-00 (Cont.)

7R Switch Circuit Controller
Circuit 48950-312-00, Sheet 4

Note 1: This wiring includes shunts and monitors both the Normal and Reverse point positions at all times with two 7R Controllers.
When the normal switch point opens 1/4" the normal bias neutral indication relay is shunted.
When reverse point opens 1/4" the reverse bias neutral indication relay is shunted.

Note 2: Contacts #21 and #22 are Positive Break Normally Closed, Contacts #13 and #14 are Normally Open.

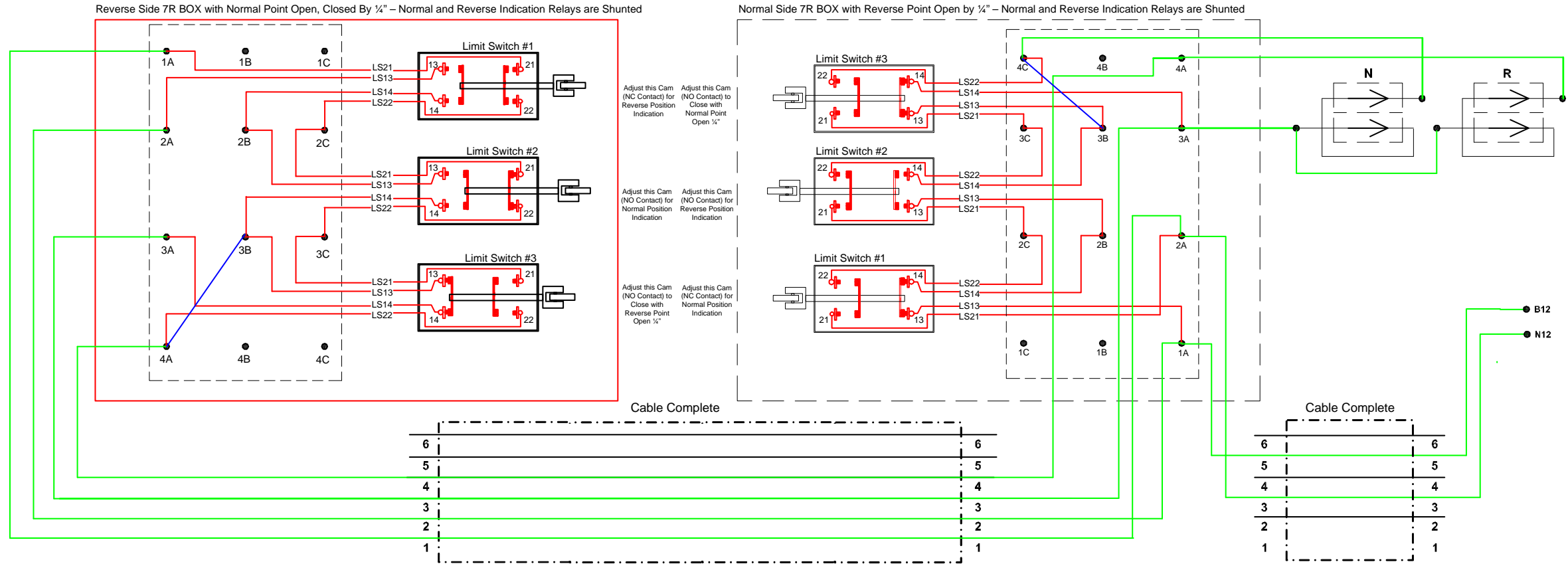

Figure A-3. 7R Switch Circuit Controller Circuit 48950-312-00 (Cont.)

7R Switch Circuit Controller
Circuit 48950-313-00, Sheet 1

Note 1: This circuit checks the Normal point position only at all times in a crossover. One 7R Controller is connected to each of the switch points.
 When either normal switch point opens ¼" the bias neutral indication relay is shunted

Note 2: Contacts #21 and #22 are Positive Break Normally Closed, Contacts #13 and #14 are Normally Open.

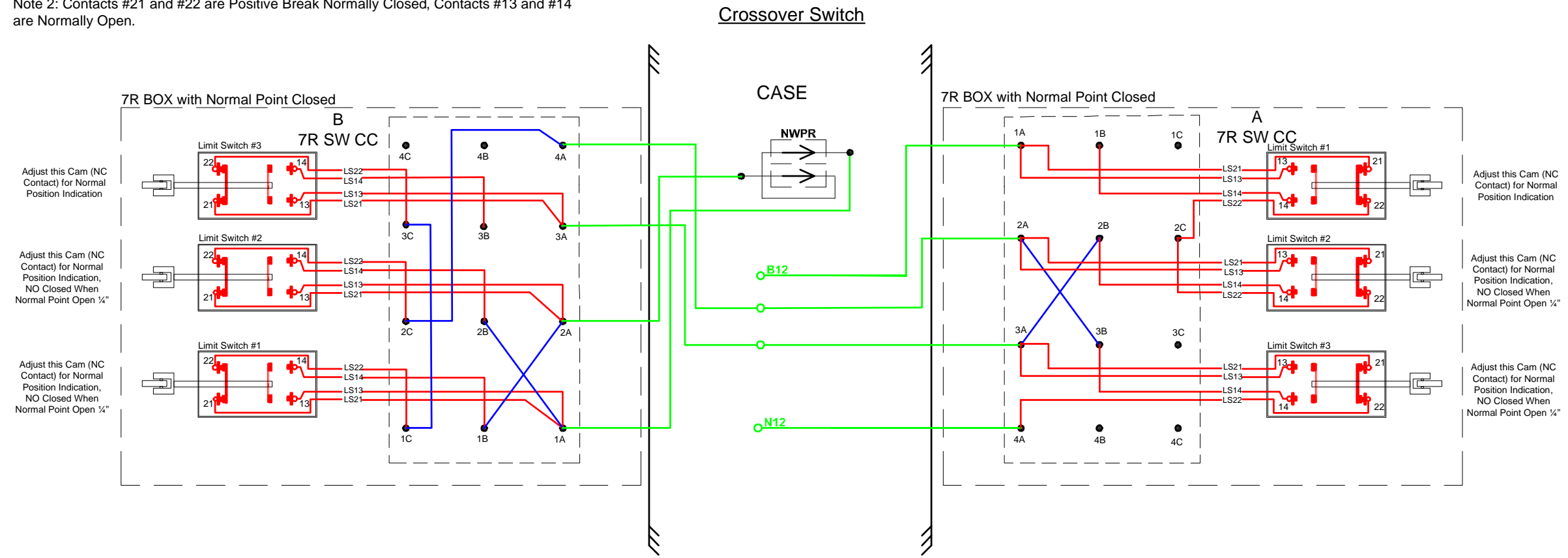

Figure A-4. 7R Switch Circuit Controller Circuit 48950-313-00

7R Switch Circuit Controller
Circuit 48950-313-00, Sheet 2

Note 1: This circuit checks the Normal point position only at all times in a crossover. One 7R Controller is connected to each of the switch points.
 When either normal switch point opens 1/4" the bias neutral indication relay is shunted

Note 2: Contacts #21 and #22 are Positive Break Normally Closed, Contacts #13 and #14 are Normally Open.

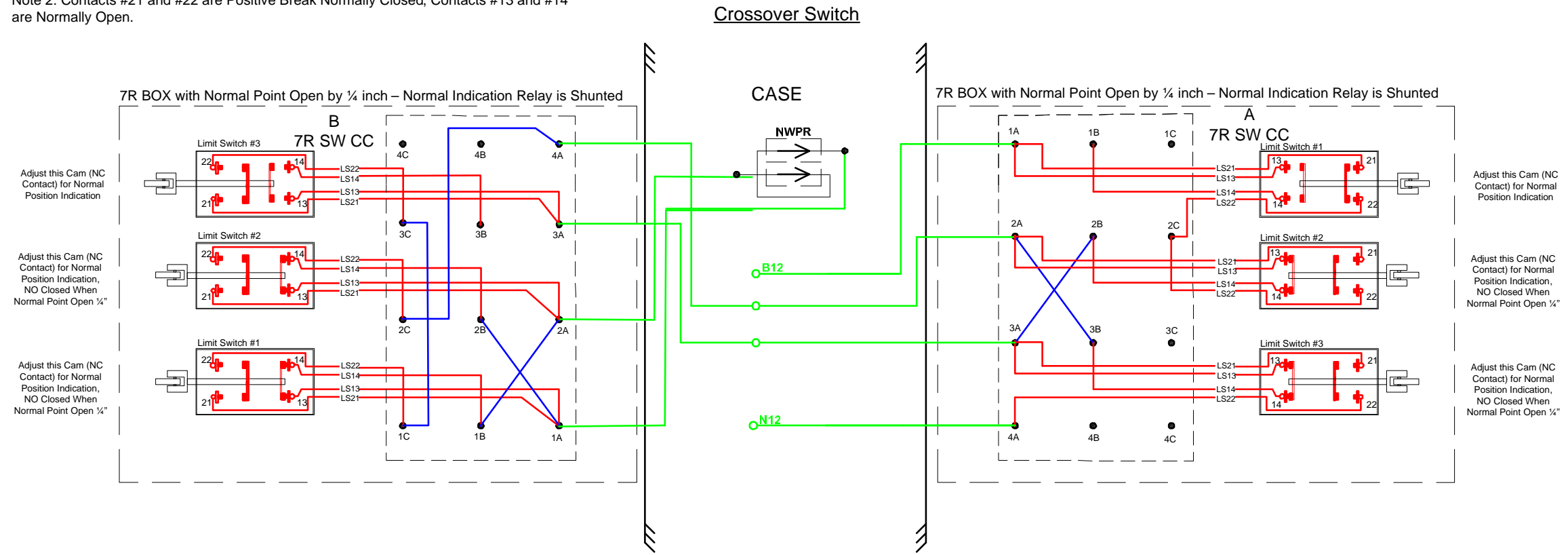

Figure A-4. 7R Switch Circuit Controller Circuit 48950-313-00 (Cont.)

THIS PAGE INTENTIONALLY LET BLANK.

**FOR QUESTIONS AND INQUIRIES, CONTACT CUSTOMER SERVICE AT
1-800-717-4477
OR
WWW.ALSTOMSIGNALINGSOLUTIONS.COM**

**ALSTOM SIGNALING INC.
1025 JOHN STREET
WEST HENRIETTA, NY 14586**