



iVPI



Integrated  
Vital Processor  
Interlocking Control  
System

Subrack  
Configuration

Copyright © 2008, 2011 Alstom Signaling Inc.

Subrack Configuration Manual  
**P2521B, Volume 2**





iVPI

Integrated  
Vital Processor  
Interlocking Control  
System

Subrack  
Configuration

Copyright © 2008, 2011 Alstom Signaling Inc.

Subrack Configuration Manual  
**Alstom Signaling Inc.**

P2521B, Volume 2, Rev. 2, February 2011, Printed in U.S.A.



## LIST OF EFFECTIVE PAGES

### **P2521B, Volume 2, iVPI Integrated Vital Processor Interlocking Control System Subrack Configuration Manual**

ORIGINAL ISSUE DATE: October 2008

CURRENT REVISION AND DATE: Rev. 2, February 2011, updated with  
commercialized components

PAGE	CHANGE OR REVISION LEVEL
Cover	Feb/11
Title page	Feb/11
Preface	Feb/11
i thru ii	Feb/11
1-1 thru 1-10	Feb/11
2-1 thru 2-2	Feb/11
3-1 thru 3-6	Feb/11
4-1 thru 4-4	Feb/11

THIS PAGE INTENTIONALLY LEFT BLANK.

**PREFACE**

**NOTICE OF CONFIDENTIAL INFORMATION**

Information contained herein is confidential and is the property of Alstom Signaling Incorporated. Where furnished with a proposal, the recipient shall use it solely to evaluate the proposal. Where furnished to customer, it shall be used solely for the purposes of inspection, installation or maintenance. Where furnished to a supplier, it shall be used solely in the performance of the contract. The information shall not be used or disclosed by the recipient for any other purposes whatsoever.

**FOR QUESTIONS AND INQUIRIES, CONTACT CUSTOMER SERVICE AT  
1-800-717-4477  
OR  
WWW.ALSTOMSIGNALINGSOLUTIONS.COM**

**ALSTOM SIGNALING INC.  
1025 JOHN STREET  
WEST HENRIETTA, NY 14586**

**REVISION LOG**

<b>Revision</b>	<b>Date</b>	<b>Description</b>	<b>By</b>	<b>Checked</b>	<b>Approved</b>
1	October 2008	Original issue	MAS	RIH	NI
2	February 2011	Updated with commercialized components	MAS	RIH	NI

THIS PAGE INTENTIONALLY LEFT BLANK.

## **ABOUT THE MANUAL**

This manual is intended to describe the Alstom Integrated Vital Processor Interlocking Control System, (iVPI) Subrack configuration, including part numbers and Subrack illustrations. This manual is part of a 5 volume set of manuals. The set is summarized in Section 1.

The information in this manual is arranged into sections. The title and a brief description of each section follow:

**Section 1 – SYSTEM SUBRACK:** This section provides an overview of iVPI System Subrack related options including part numbers and a brief explanation of their application.

**Section 2 – CIRCUIT BOARD KEYING:** This section provides the keying information for the circuit boards used in the iVPI System.

**Section 3 – SUBRACK HARDWARE:** This section provides examples of iVPI Subrack hardware.

**Section 4 – SPECIAL TOOLS:** This section shows the iVPI wiring and B-Relay tools.

THIS PAGE INTENTIONALLY LEFT BLANK.

## **MANUAL SPECIAL NOTATIONS**

In the Alstom manuals, there are three methods used to convey special informational notations to the reader. These notations are warnings, cautions, and notes. Both warnings and cautions are readily noticeable by boldface type two lines beneath the caption.

### Warning

A warning is the most important notation to heed. A warning is used to tell the reader that special attention needs to be paid to the message because if the instructions or advice is not followed when working on the equipment then the result could be either serious harm or death. The sudden, unexpected operation of a switch machine, for example, or the technician contacting the third rail could lead to personal injury or death. An example of a typical warning notice follows:

#### **WARNING**

DISCONNECT MOTOR ENERGY WHENEVER WORKING ON SWITCH LAYOUT OR SWITCH MACHINE. UNEXPECTED OPERATION OF MACHINE COULD CAUSE INJURY FROM OPEN GEARS, ELECTRICAL SHOCK, OR MOVING SWITCH POINTS.

### Caution

A caution statement is used when an operating or maintenance procedure, practice, condition, or statement, which if not strictly adhered to, could result in damage to or destruction of equipment. A typical caution found in a manual is as follows:

#### **CAUTION**

Turn power off before attempting to remove or insert circuit boards into a Subrack. Boards can be damaged if power is not turned off.

### Note

A note is normally used to provide minor additional information to the reader to explain the reason for a given step in a test procedure or to just provide a background detail. An example of the use of a note follows:

#### **NOTE**

A capacitor may be mounted on the circuit board with a RTV adhesive. Use the same color RTV.

THIS PAGE INTENTIONALLY LEFT BLANK.

## TABLE OF CONTENTS

Topic	Page
<b>1. SECTION 1 – SYSTEM SUBRACK .....</b>	<b>1-1</b>
1.1. GENERAL .....	1-1
1.2. MANUAL SET ORGANIZATION .....	1-1
1.3. SUBRACK TERMS.....	1-2
1.4. SUBRACK CONFIGURATION .....	1-3
1.5. SUBRACK WIRING.....	1-6
1.5.1. Direct Wire.....	1-6
1.5.2. Connector Wiring.....	1-6
1.6. MOTHERBOARD .....	1-7
1.7. POWER ISOLATION UNIT.....	1-8
1.8. SUBRACK INTERFACE BOARDS.....	1-10
<b>2. SECTION 2 – CIRCUIT BOARD KEYING.....</b>	<b>2-1</b>
2.1. GENERAL .....	2-1
2.2. INTRODUCTION .....	2-1
<b>3. SECTION 3 – SUBRACK HARDWARE.....</b>	<b>3-1</b>
3.1. GENERAL .....	3-1
3.2. INTRODUCTION .....	3-1
<b>4. SECTION 4 – SPECIAL TOOLS .....</b>	<b>4-1</b>
4.1. GENERAL .....	4-1
4.2. INTRODUCTION .....	4-1

---

## LIST OF FIGURES

Description	Page
Figure 1–1. iVPI Rack and Subrack .....	1–2
Figure 1–2. 21-Slot iVPI Subrack Populated with Boards (a System) .....	1–3
Figure 1–3. Dual 10-Slot iVPI Subrack Populated with Boards (a System).....	1–4
Figure 1–4. Power Isolation Unit .....	1–9
Figure 2–1. Registration Keying Positions on Circuit Board .....	2–1
Figure 3–1. 21-slot Subrack (Empty iVPI Chassis with Motherboard).....	3–1
Figure 3–2. Example Board Placement for Single 21-slot Subrack iVPI System .....	3–2
Figure 3–3. Dual 10-slot Subrack (Empty iVPI Chassis with Motherboards).....	3–3
Figure 3–4. Example Board Placement for Dual 10-slot Subrack iVPI System.....	3–4
Figure 3–5. B-Relay, B1 Neutral, Regular Release, 100 Ohm (Used with VRD Board), P/N 56001-787-05 .....	3–5
Figure 4–1. Crimp Tool, B-Relay Crimp Terminals, P/N 24745-148-00.....	4–2
Figure 4–2. Crimp Tool, DIN Type F, P/N 24745-166-00, 24745-167-00, 24745-168-00, 24745-169-00 .....	4–3
Figure 4–3. Spanner Wrench for B-Relay 3E Post.....	4–3
Figure 4–4. PLCC 32 Pin IC Terminal Extraction Tool .....	4–4
Figure 4–5. Terminal Extraction Tool, B Relay Terminal, P/N 59688-000-00.....	4–4
Figure 4–6. Terminal Extraction Tool, DIN Type F, P/N 59688-038-00 .....	4–4

---

## LIST OF TABLES

Description	Page
Table 1–1. Subrack Part Numbers .....	1–5
Table 1–2. Power Isolation Unit Connections.....	1–8
Table 2–1. Vital and Non-Vital PC Board Keying .....	2–2
Table 4–1. Special Tools.....	4–1

---

# 1. SECTION 1 – SYSTEM SUBRACK

## 1.1. GENERAL

This manual provides an overview of Subrack related options including part numbers and a brief explanation of their application. Be aware that the Subrack configurations provided are examples only, refer to the location Book Of Plans (BOP) to determine the components used in the site configuration. Note that all part numbers are Alstom numbers unless otherwise noted.

See P2521B, Volume 1 for capacity overview and hardware criteria.

## 1.2. MANUAL SET ORGANIZATION

This manual is part of a 5 volume set supporting the iVPI system. The set is organized as follows:

- Volume 1, Installation, Operation, and Theory Manual includes general overview of the field installation and setup of the iVPI system; including capacity guidelines and allowable board combinations, system operation, and theory of operation.
- Volume 2, Subrack Configuration, is this document. It describes the Subrack configuration including cables and power supplies.
- Volume 3, Vital Subsystem, includes the Vital subsystem board drawings and board reference data.
- Volume 4, Non-Vital Subsystem, includes non-vital subsystem board drawings and board reference data.
- Volume 5, Maintenance and Troubleshooting, describes system maintenance and troubleshooting, including discussion of diagnostics and references for the applicable software and hardware manuals.

### 1.3. SUBRACK TERMS

The iVPI System is highly modular in design, implemented in a 19 inch rack mounted card cage (Subrack) with a set of plug-in printed circuit boards (boards) that are applied in varying quantities to meet the needs of specific applications.

The terminology used to define the Subrack and its components is as follows:

- A Subrack is a Chassis with Motherboard
- A System is one or more Subracks filled with the appropriate boards for the application
- When a System is configured with more than one Subrack populated with boards, the individual populated Subracks are Subsystems

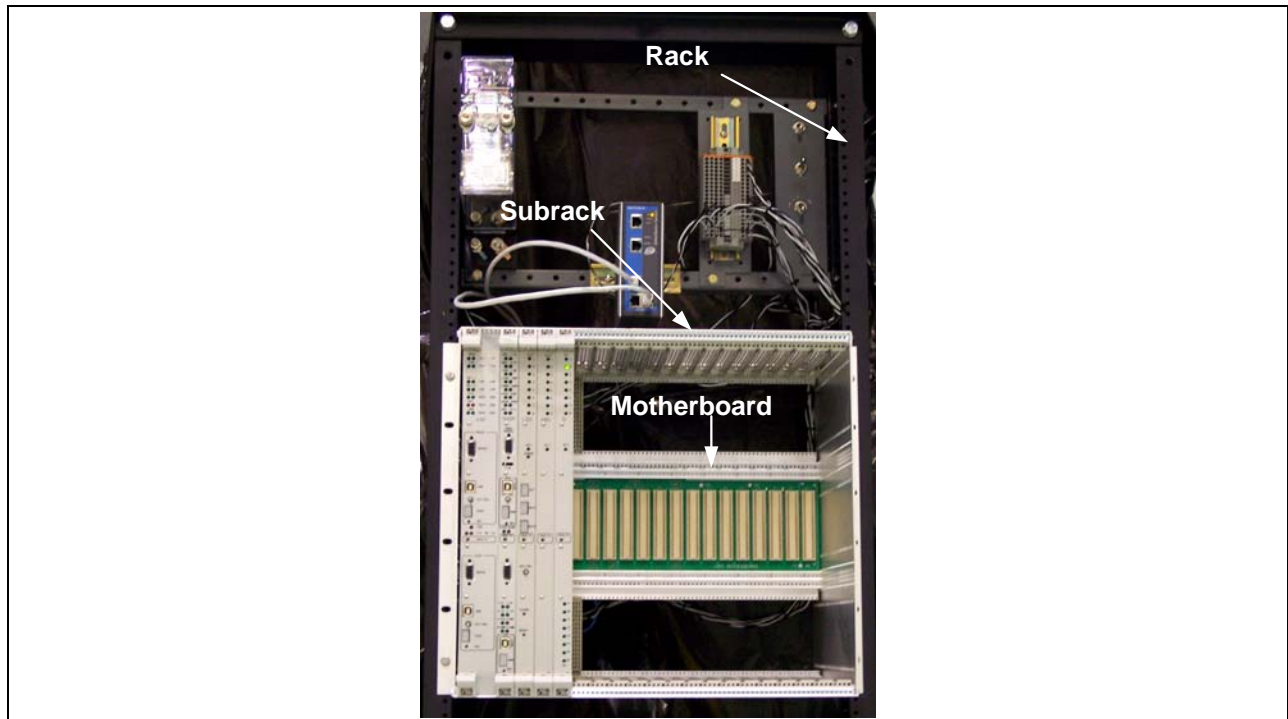

Figure 1–1. iVPI Rack and Subrack

### 1.4. SUBRACK CONFIGURATION

A single iVPI System is housed in one to four Subracks. Each Subrack has space for twenty-one (21) or ten (10) printed circuit boards. Only two boards in the new iVPI Subrack require a specific slot location. The VSP board is a double wide board assigned to slots 1 and 2. The single slot wide NVSP board can be assigned to any of slots 3 through 8. The iVPI Subrack allows for any other board to be inserted into any slot other than 1 or 2, reducing both set-up and maintenance time. Figure 1–2 is an illustration showing a full 21-slot Subrack. Figure 1–3 is an illustration showing a Dual 10-slot Subrack. Any unused board slots are covered with blank panels.

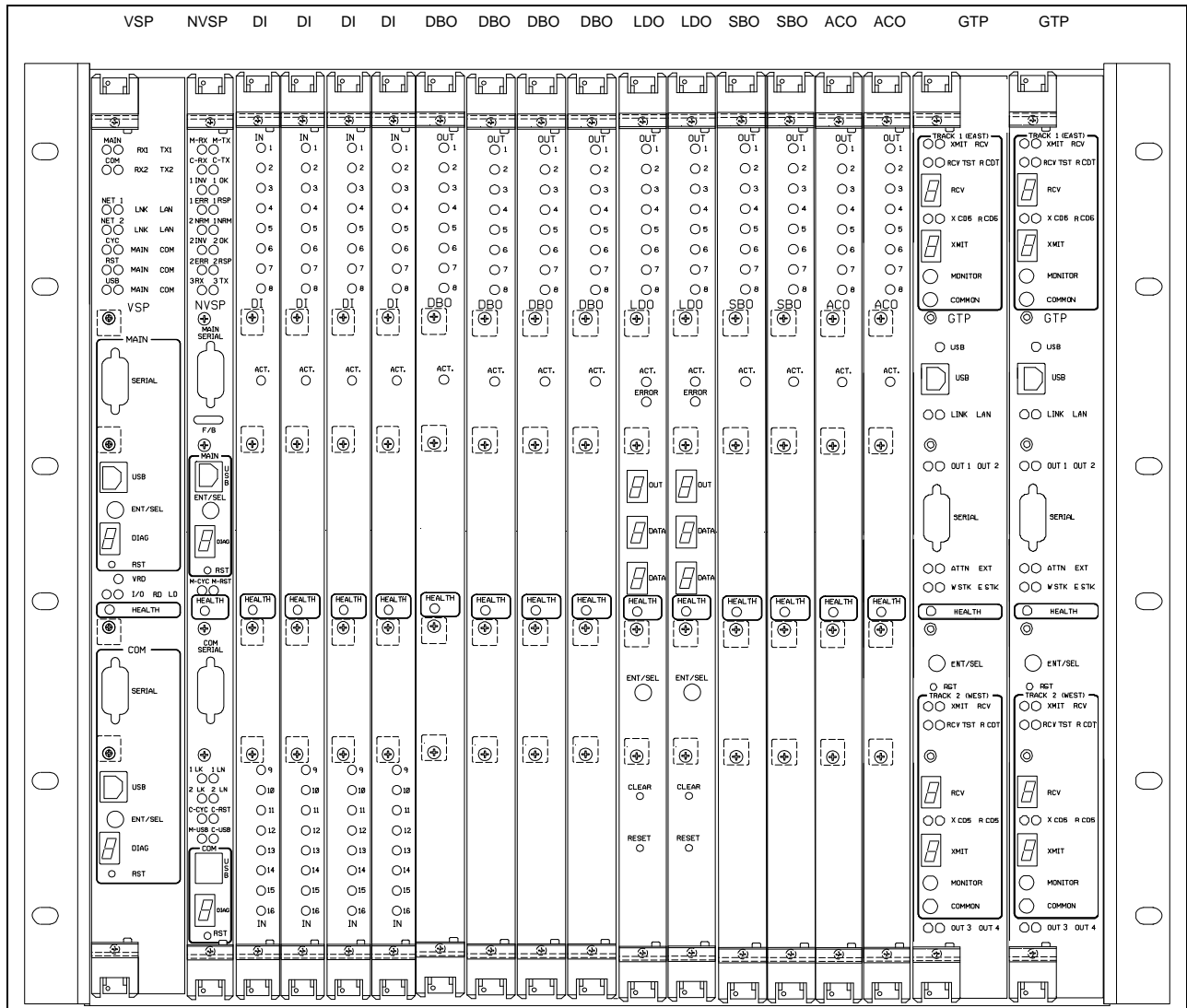

Figure 1–2. 21-Slot iVPI Subrack Populated with Boards (a System)

# System Subrack

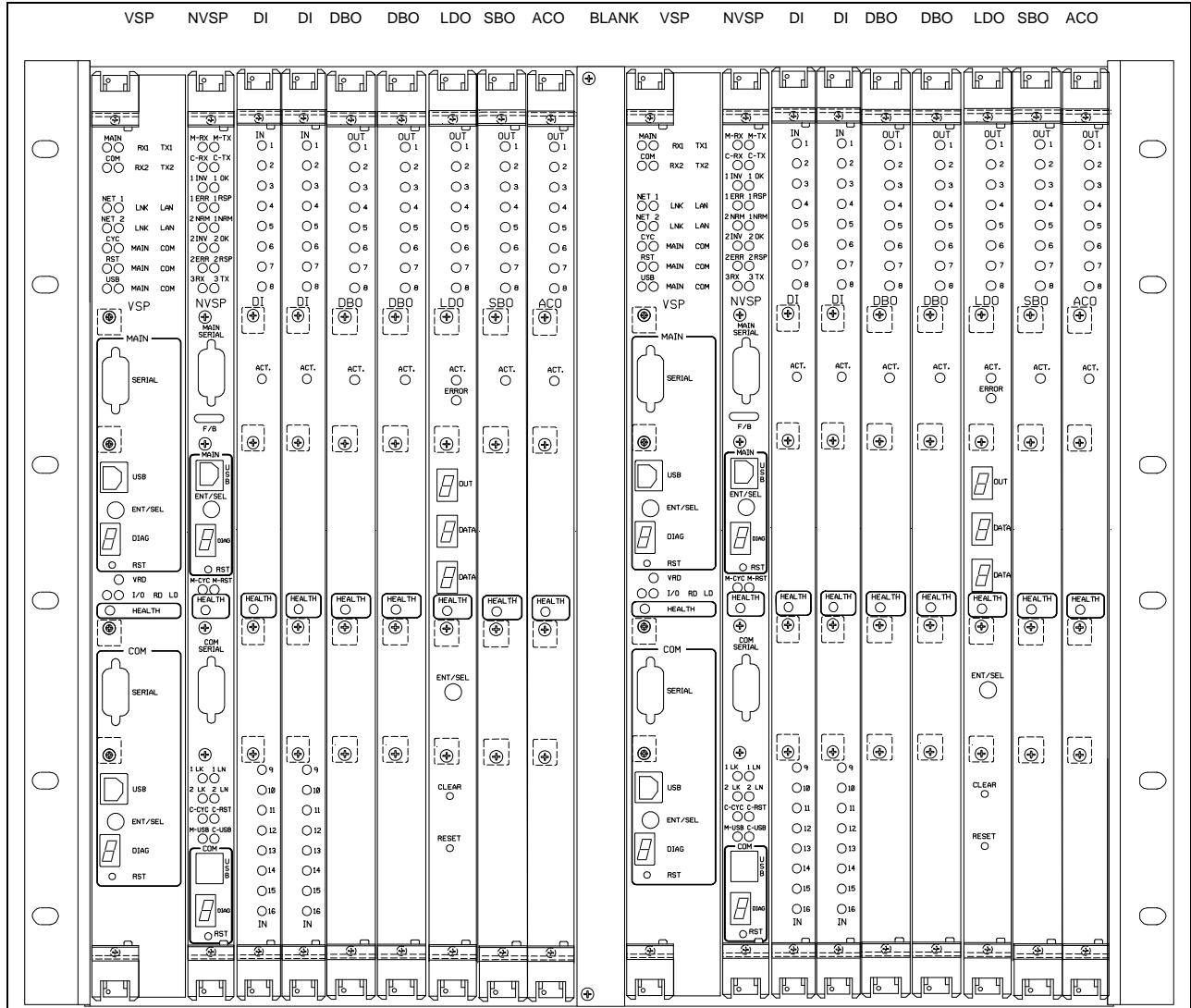

Figure 1–3. Dual 10-Slot iVPI Subrack Populated with Boards (a System)

Table 1–1. Subrack Part Numbers

Description	Part Number
21-Slot iVPI Subrack, Direct Wire, with P2 Motherboard, 12 VDC Power Isolation, Power Supply 9-16 VDC Main Chassis	31038-823-02
21-Slot iVPI Subrack, Direct Wire, with P2 Motherboard, 12 VDC Power Isolation, Power Supply 9-16 VDC, Expansion Chassis 1	31038-823-03
21-Slot iVPI Subrack, Direct Wire, with P2 Motherboard, 12 VDC Power Isolation, Power Supply 9-16 VDC, Expansion Chassis 2	31038-823-04
21-Slot iVPI Subrack, Direct Wire, with P2 Motherboard, 12 VDC Power Isolation, Power Supply 9-16 VDC, Expansion Chassis 3	31038-823-05
Dual 10-slot Subrack, both are Direct Wire, with two independent P2 Motherboards, 12 VDC Power Isolation Units, Power Supply 9-16 VDC	31038-833-01

See Figure 3–1 for the 21-Slot Subrack assembly with motherboard drawing and Figure 3–3 for the Dual 10-Slot Subrack assembly with Motherboards drawing.

When a single iVPI System is expanded into more than one Subrack, the System Bus (incorporated in the Motherboard) is extended to the expander Subracks permitting all boards in the System to operate as if directly interfaced to the processor with no degradation in system performance. iVPI can support up to four Subracks containing the main system Subrack, plus three expansion Subracks. There are three different expansion motherboards, one for each Expansion Subrack (identified as P2 Motherboard Expansion 1, 2, and 3).

All Vital input/output lines have built-in secondary transient protection to prevent disruption of service from external interference.

In an expansion Subrack configuration slot 1 contains a Bus Expansion board (BEX) and if required by application, an NVSP board could be located in slots 2 through 8.

All iVPI printed circuit boards:

- Are mechanically keyed to prevent placement of boards in the Subrack in the wrong card slot
- Contain LED indicators along the front edge of the board that display the operating status of the board to assist in maintenance
- Display I/O functions with individual LED indicators to indicate the status of each I/O point

Vital iVPI printed circuit boards are also electrically keyed. All Vital input/output lines have built-in secondary transient protection to prevent disruption of service from external interference.

## 1.5. SUBRACK WIRING

### 1.5.1. Direct Wire

The Subrack is configured to be directly wired into the PCB edge connectors in the Subrack. This Subrack configuration does not allow for quick removal of the Subrack from a wired rack. However, all the PCBs can be removed and no active electronic components are left in the Subrack.

### 1.5.2. Connector Wiring

The Subrack can be configured to include a Bus Expansion 31166-460-01. This I/O expansion includes preconfigured I/O Ports. It allows for cables to be installed based on the PCB configuration.

## 1.6. MOTHERBOARD

The iVPI Motherboard has continuous power and signal buses running the length of the Subrack (slots 1-21 or slots 1-10) through 160-pin connectors. These buses are partitioned for vital interface boards, non-vital interface boards and a serial interface. Each slot is electrically identified by 7 address configuration pins that are connected to a board as it is plugged into the backplane. See Section 2 for circuit board keying information.

When a VSP board is installed, the backplane passes the control signals from the VSP board to one or more vital input or output boards.

## 1.7. POWER ISOLATION UNIT

The 12VDC (nominal) power to the backplane is supplied through a separate Power Isolation Unit (31166-447-01) that is mounted to the rear side of the backplane via six power-tap high current screw connectors. The Power Isolation Unit provides the safety isolation between the battery voltage and the Motherboard. This eliminates the need for an external DC/DC Converter.

External power is brought into the Power Isolation Unit via terminal block TB1. Terminal blocks TB4 and TB5 provide local distribution of the input voltage for accessories such as a local control panel. Remote supply enable of the Power Converter Module is provided through TB2 and TB3. Connecting these two terminals together (through a toggle switch) enables the supply and generates the isolated output voltage. Isolated 12VDC is provided for external use through TB6 & TB7.

Connections TB2, TB3, TB4, TB5, TB6 and TB7 incorporate levers for wire installation and removal. No special tools are required. Connection TB1 requires the use of a small flat blade screwdriver, which is inserted into the top, rectangular opening. The wire is inserted into the lower round opening. Press the screwdriver into the rectangular opening at a slight downward angle to insert/release the wire.

Table 1–2. Power Isolation Unit Connections

Function	Connections
Input Power:	TB1: 12VDC (nominal) Input Power, Spring Clamp Terminal Block 24 - 6 AWG TB1-1: 12VCOM TB1-2: 12VDC TB4 and TB5: 2-Position Spring Clamp Block 28 - 12 AWG TB4: DC IN – (connected to TB1-1) TB5: DC IN + (connected to TB1-2)
Output Enable:	TB2 and TB3: 2-Position Spring Clamp Block 28 - 12 AWG
12 V Output:	TB6 and TB7: 2-Position Spring Clamp Block 28 - 12 AWG TB6: 12VCOM (isolated) TB7: 12VDC (isolated)

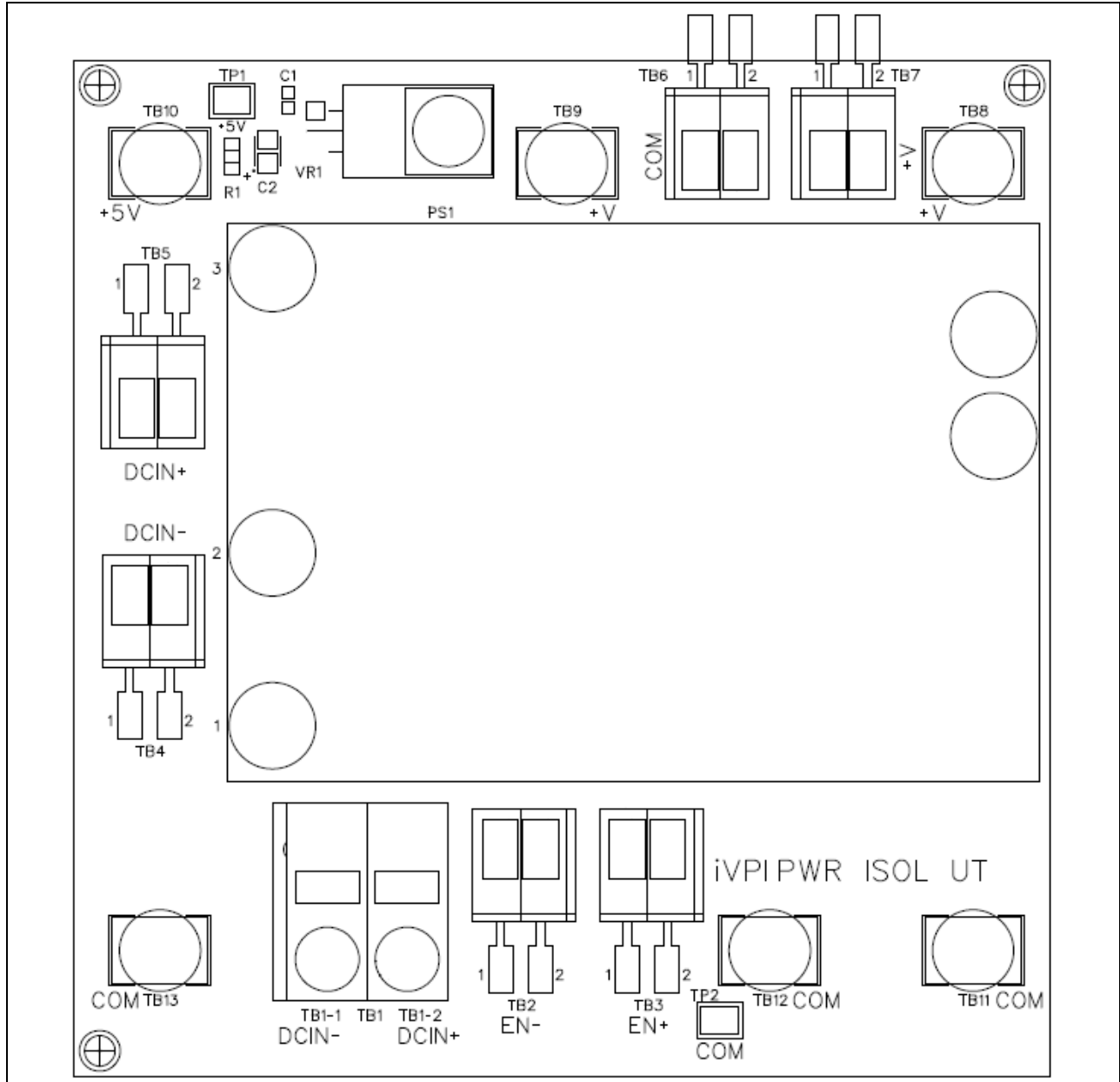

Figure 1-4. Power Isolation Unit

## 1.8. SUBRACK INTERFACE BOARDS

Based on the application, Subrack interface boards may be used for communication or expansion in the iVPI configuration.

There are three communication interface boards:

- System Connectivity Board: VSP, P3, MAC, two Ethernet Ports RJ45, Health Monitor, VRD Connections (P/N 31166-473-01) discussed in P2521B, V3, Vital Subsystem
- NVSP, P1, two Ethernet Ports RJ45 Connections (P/N 31166-474-01) discussed in P2521B, V4, Non-Vital Subsystem
- NVSP, P3, MAC, Health Monitor, three Low Speed Serial Communications Ports (P/N 31166-475-01) discussed in P2521B, V4, Non-Vital Subsystem

There is one expansion interface board:

- VSP and BEX, P1, Motherboard Expansion Bus Interface (P/N 31166-485-01) discussed in P2521B, V3, Vital Subsystem

## 2. SECTION 2 – CIRCUIT BOARD KEYING

### 2.1. GENERAL

This section provides the keying information for the iVPI circuit boards.

### 2.2. INTRODUCTION

All circuit boards used in the iVPI system are mechanically keyed to a specific slot in the iVPI Subrack.

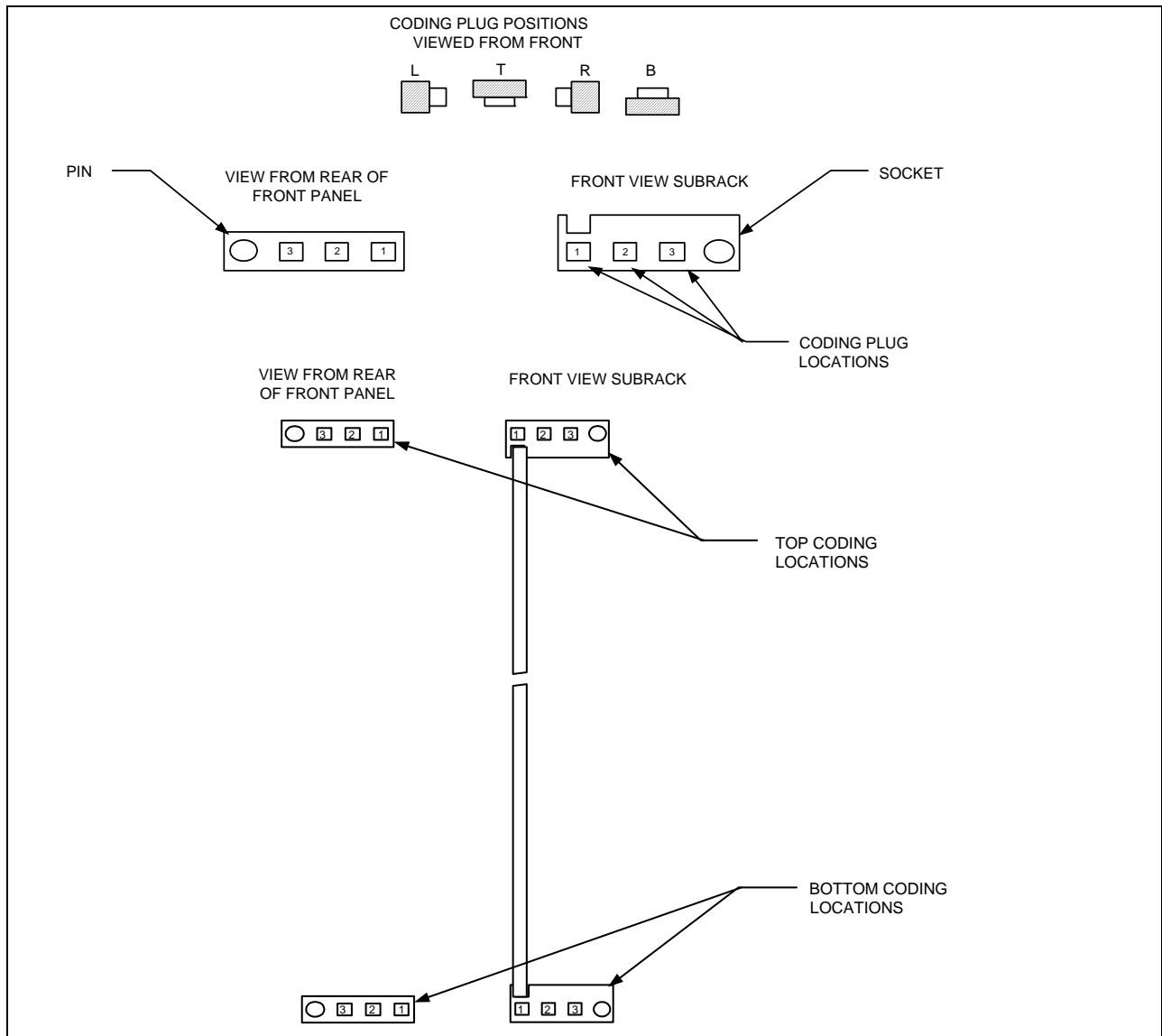

Figure 2–1. Registration Keying Positions on Circuit Board

Vital and non-vital PC board keying information is provided in Table 2–1.

Table 2–1. Vital and Non-Vital PC Board Keying

Board Type	Keying Position	
	Board	Chassis
<b>Vital Boards</b>		
VSP - Vital System Processor (31166-427-01)	T-T-T	B-B-B
ACO - AC Output (31166-432-01)	T-R-R	B-R-R
ACO - AC Output Low Current (31166-432-02)	R-R-T	B-R-B
CRG - Code Rate Generator Solid State (31166-459-01)	T-L-R	B-L-R
CRG - Code Rate Generator Vital Relay (31166-459-02)	R-T-L	R-B-L
DBO - Double Break Output (31166-433-01)	T-R-B	B-R-T
DI - Direct Input (31166-429-01)	T-T-B	B-B-T
DI - Direct Input LP Filters (31166-429-02)	T-L-T	B-L-B
GTP - Genrakode Track Processor (31166-434-01)	T-R-L	B-R-L
LDO - Lamp Drive Output (31166-431-01)	T-R-T	B-R-B
SBO - Single Break Output (31166-430-01)	T-T-L	B-B-L
BEX - Bus Expansion (31166-460-01)	T-B-T	B-T-B
<b>Non-Vital Boards</b>		
NVSP - Non-Vital System Processor (31166-428-01)	T-T-R	B-B-R
NVI - Non-Vital Input 18-36V (31166-457-01)	T-L-B	B-L-T
NVI - Non-Vital Input 9-16V (31166-457-02)	R-T-B	R-B-T
NVO - Non-Vital Output Relay (31166-458-01)	T-L-L	B-L-L
NVO - Non-Vital Output Solid State (31166-458-02)	T-B-R	B-T-R

### 3. SECTION 3 – SUBRACK HARDWARE

#### 3.1. GENERAL

This section provides examples of iVPI Subrack hardware. See P2521B, Volume 3 for Vital boards and P2521B, Volume 4 for non-vital boards.

#### 3.2. INTRODUCTION

Illustrations of two example iVPI Chassis appear on the following pages.

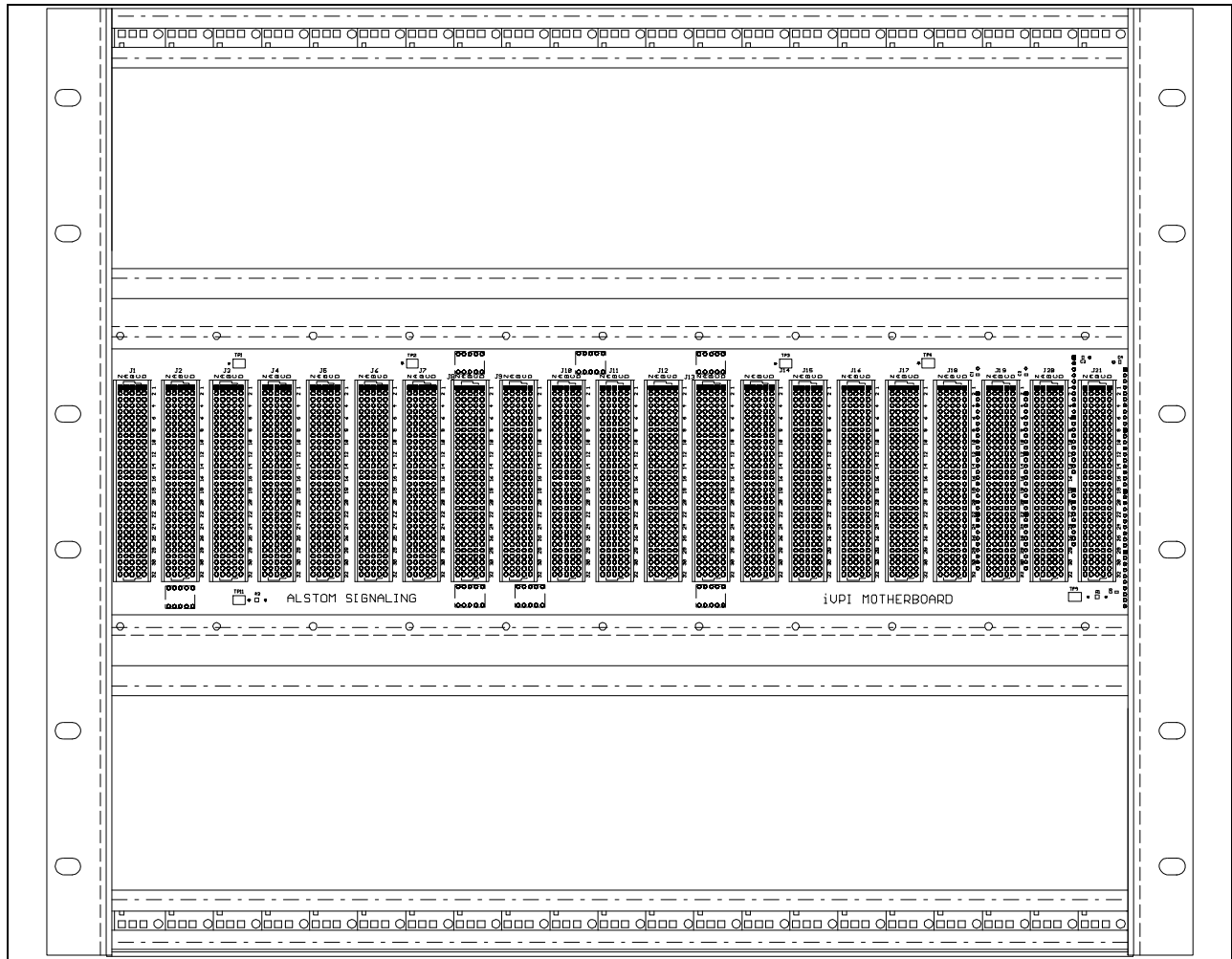

Figure 3–1. 21-slot Subrack (Empty iVPI Chassis with Motherboard)

# Circuit Board Keying

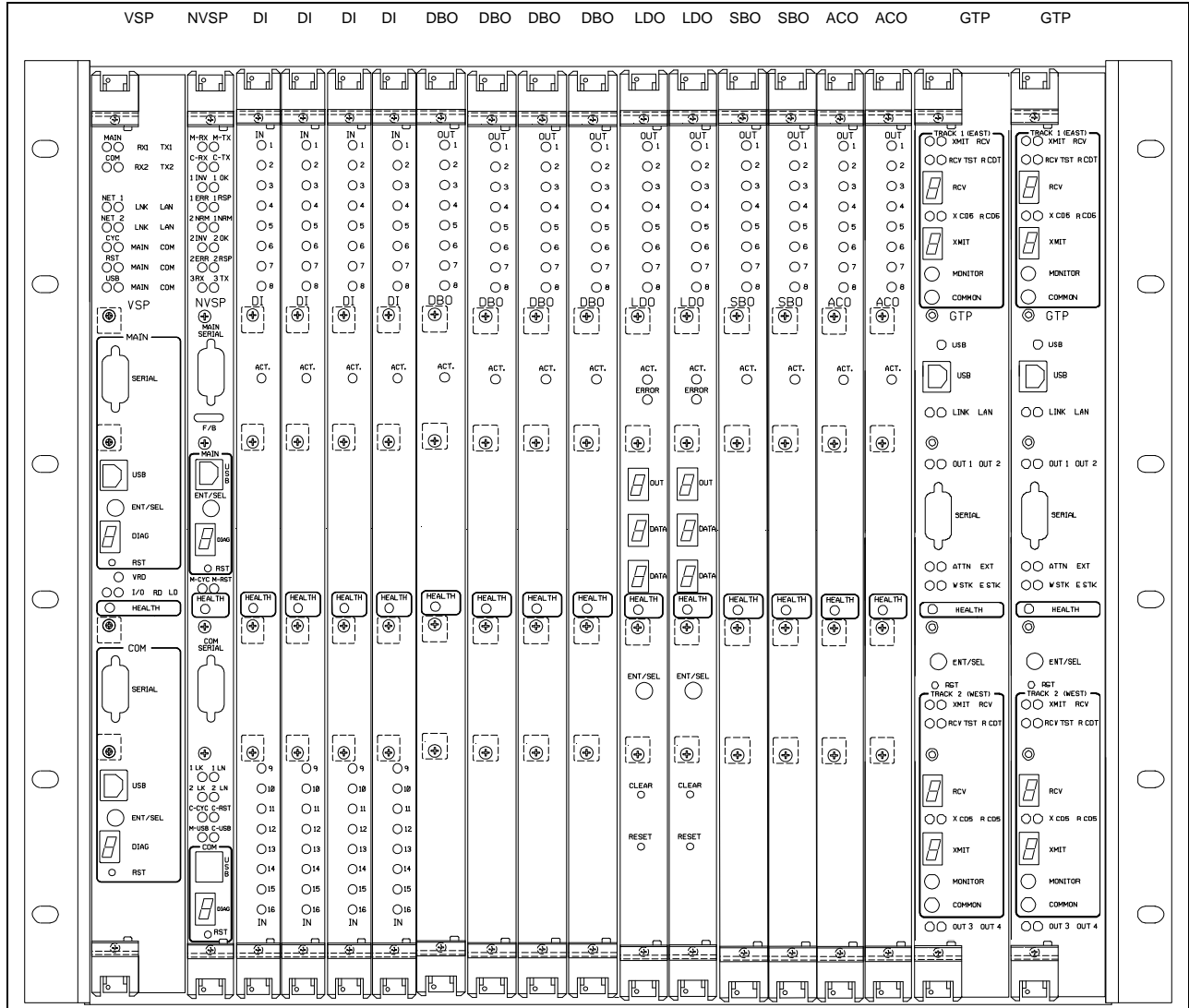

Figure 3–2. Example Board Placement for Single 21-slot Subrack iVPI System

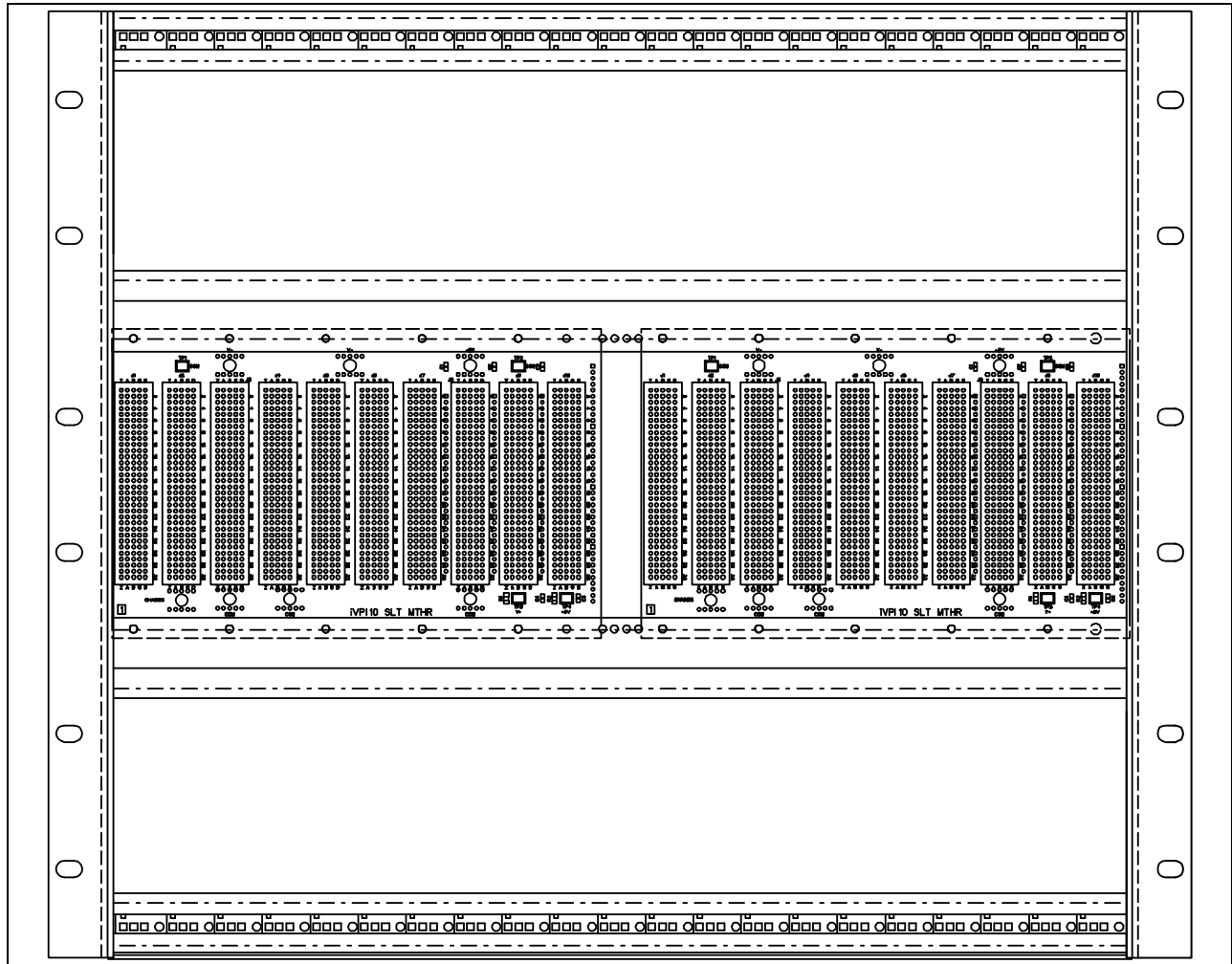

Figure 3–3. Dual 10-slot Subrack (Empty iVPI Chassis with Motherboards)

# Circuit Board Keying

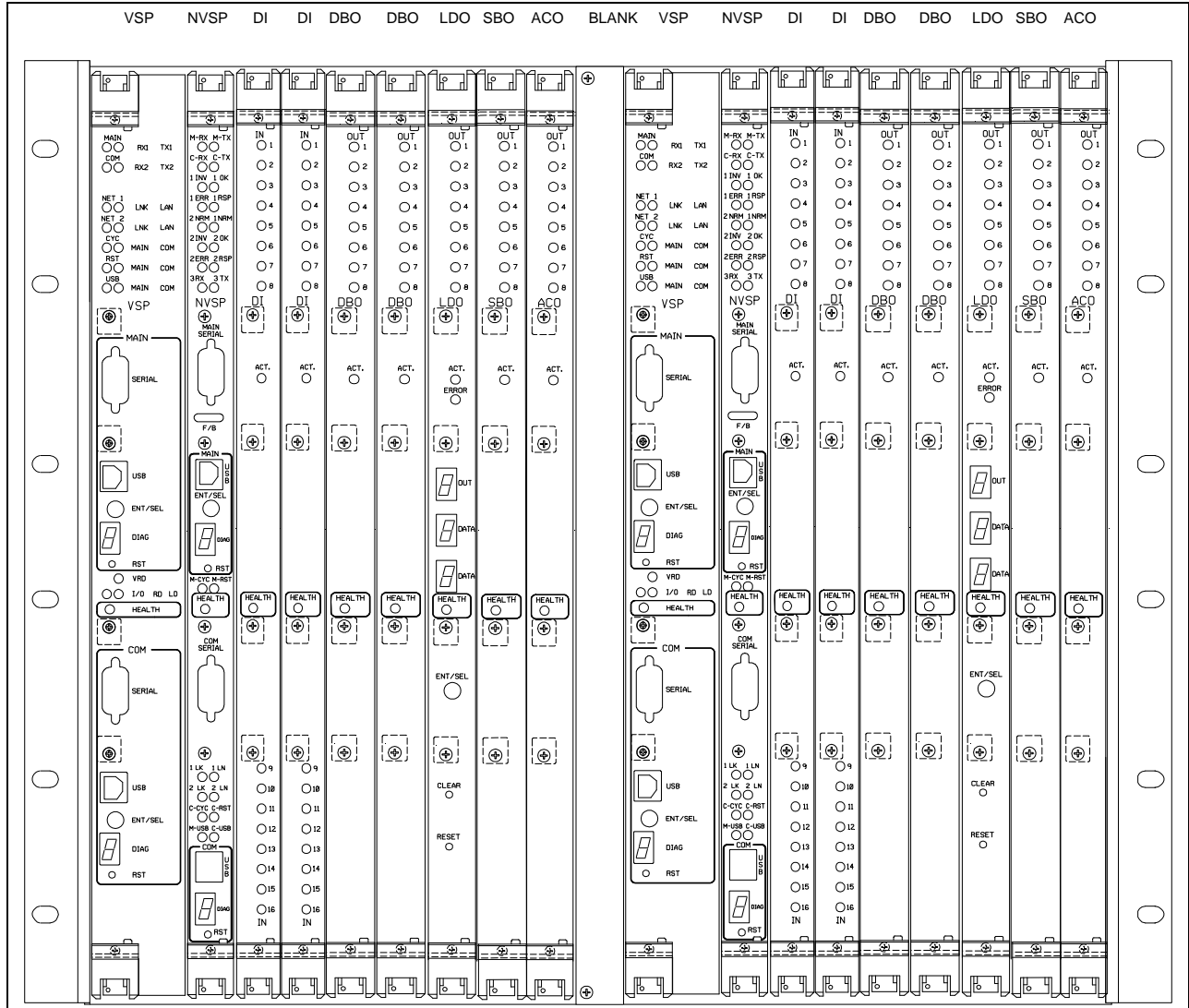

Figure 3–4. Example Board Placement for Dual 10-slot Subrack iVPI System

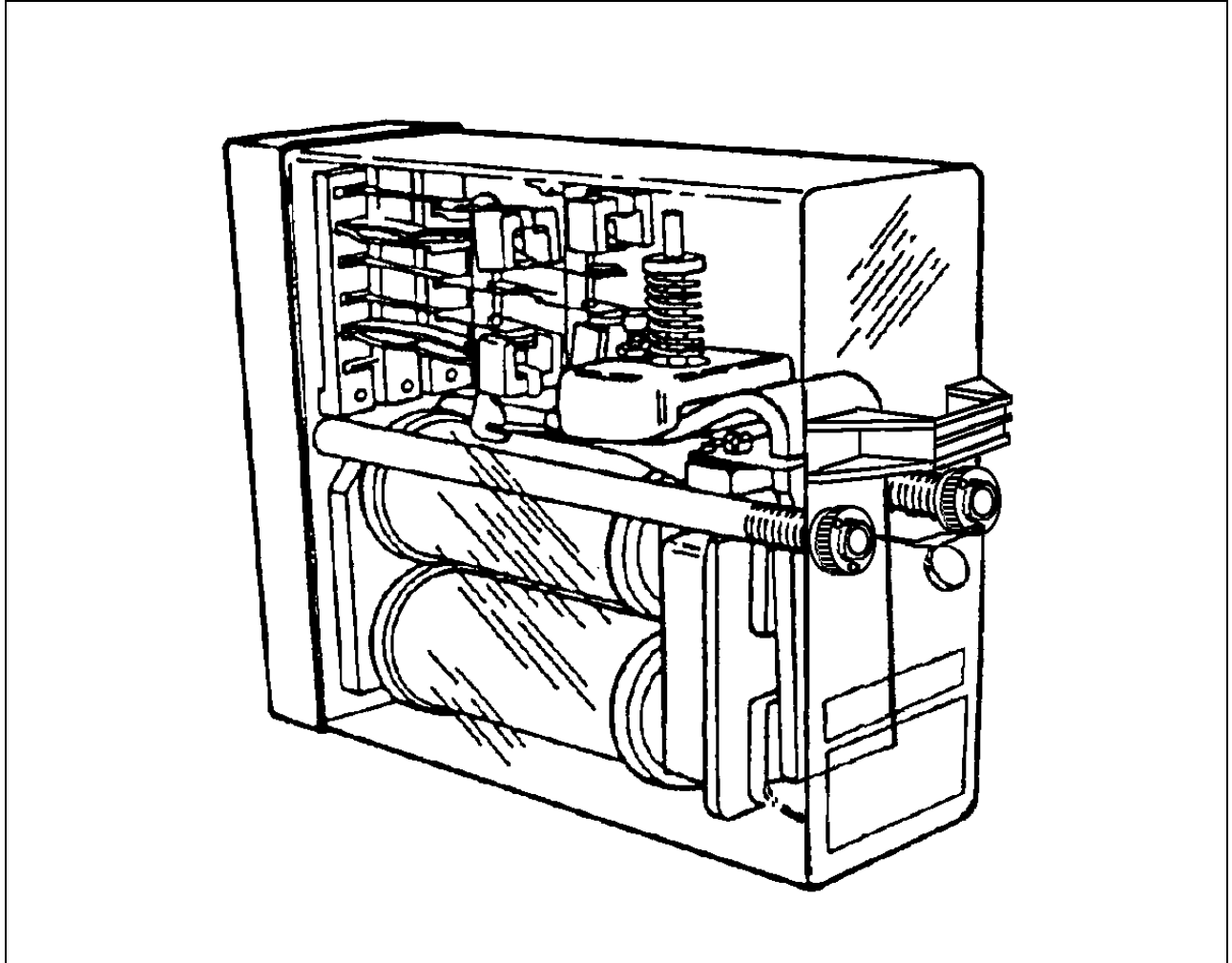

Figure 3-5. B-Relay, B1 Neutral, Regular Release, 100 Ohm (Used with VRD Board),  
P/N 56001-787-05

THIS PAGE INTENTIONALLY LEFT BLANK.

## 4. SECTION 4 – SPECIAL TOOLS

### 4.1. GENERAL

This section summarizes the Wiring and B-Relay Tools used for the iVPI Subrack.

### 4.2. INTRODUCTION

A list of special tools used for the iVPI rack wiring and B-Relay is provided in Table 4–1 followed by illustrations of the various tools.

Table 4–1. Special Tools

REF.	Description	Part Number
4–1	Crimp Tool, B-Relay Crimp Terminals, Frame w/Die	24745-148-00
4–2	Crimp Tool, DIN Type F, Crimping Tool Frame, Harting 09 99 000 0620	24745-166-00
4–2	Crimp Tool, DIN Type F, Insert-Set, Die 28-24 AWG, Harting 09 99 000 0621	24745-167-00
4–2	Crimp Tool, DIN Type F, Insert-Set, Die 26-20 AWG, Harting 09 99 000 0622	24745-168-00
4–2	Crimp Tool, Type F, Insert-Set, Die 20-16 AWG, Harting 09 99 000 0623	24745-169-00
4–3	Spanner Wrench for B-Relay 3E Post	55393-003-01
4–4	Terminal Extraction Tool PLCC 32 Pin IC Terminal Extraction Tool, AMP P/N 821980-1	Contact Alstom (Commercially available through Newark.com)
4–5	Terminal Extraction Tool, B-Relay	59688-000-00
4–6	Terminal Extraction Tool, DIN Type F, Harting 09 99 000 087	59688-038-00

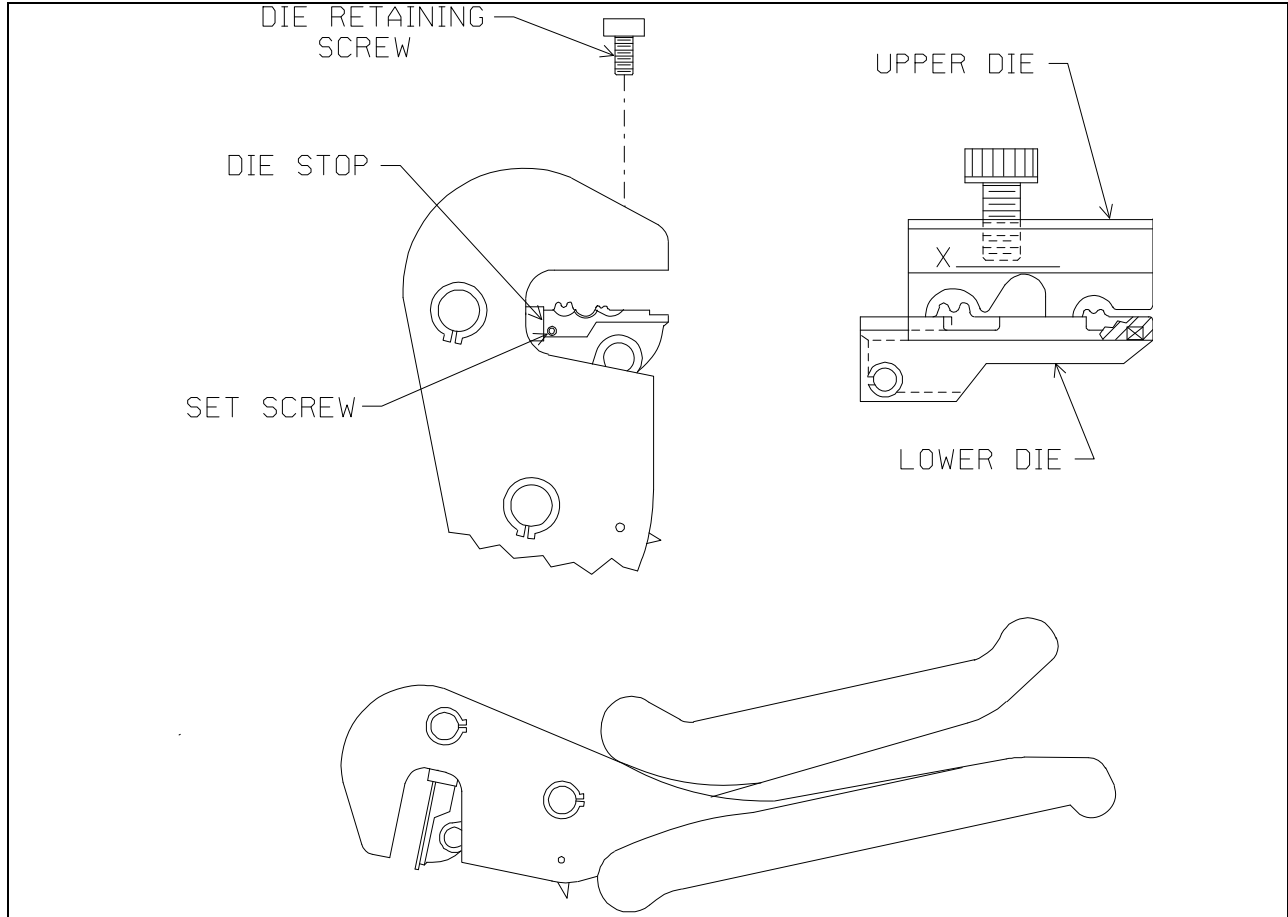

Figure 4-1. Crimp Tool, B-Relay Crimp Terminals, P/N 24745-148-00

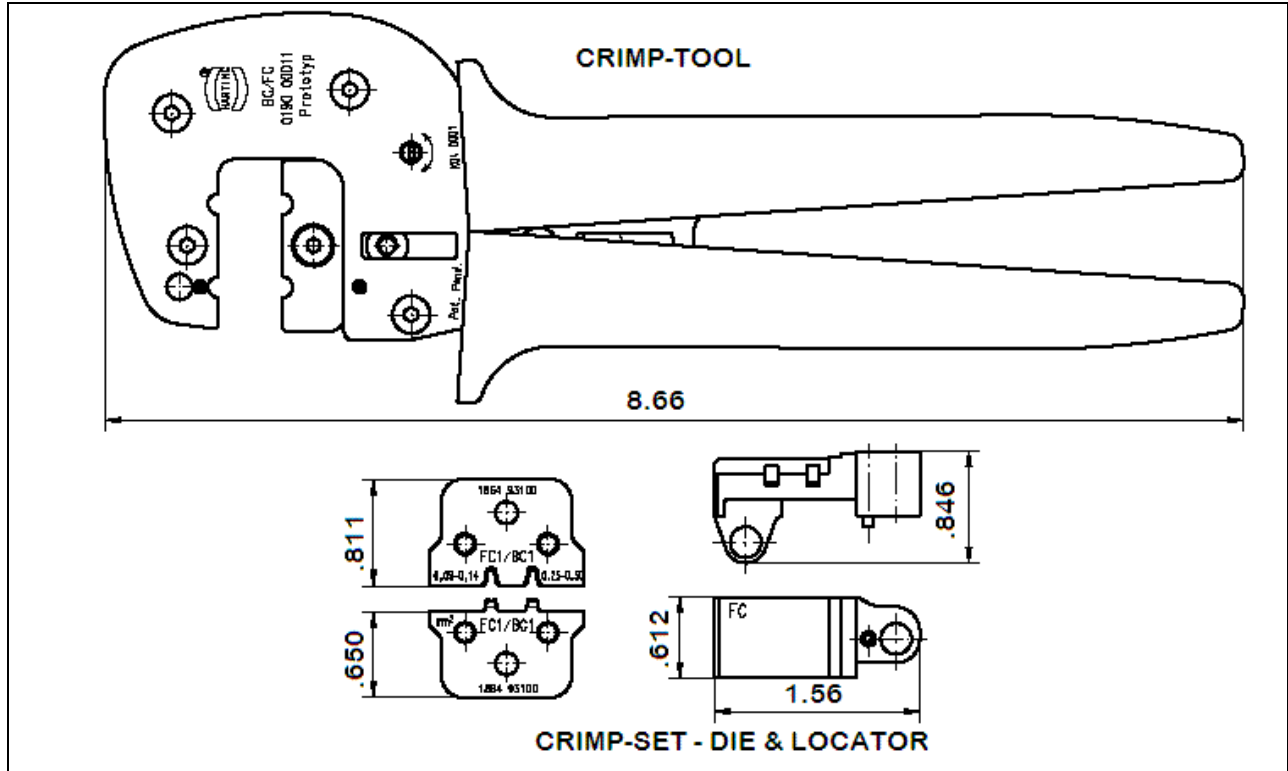

Figure 4-2. Crimp Tool, DIN Type F, P/N 24745-166-00, 24745-167-00, 24745-168-00, 24745-169-00

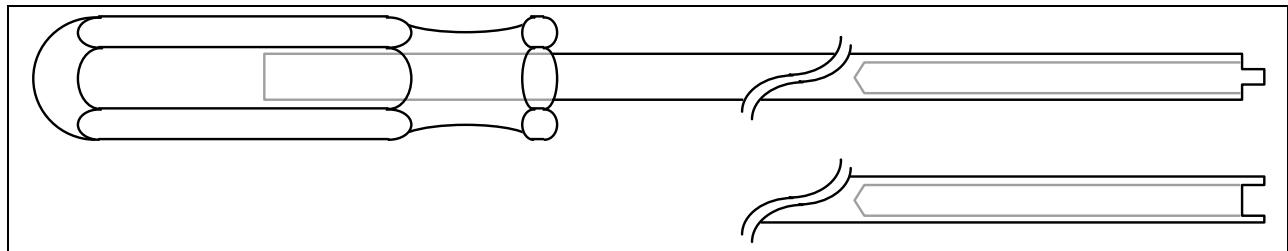

Figure 4-3. Spanner Wrench for B-Relay 3E Post

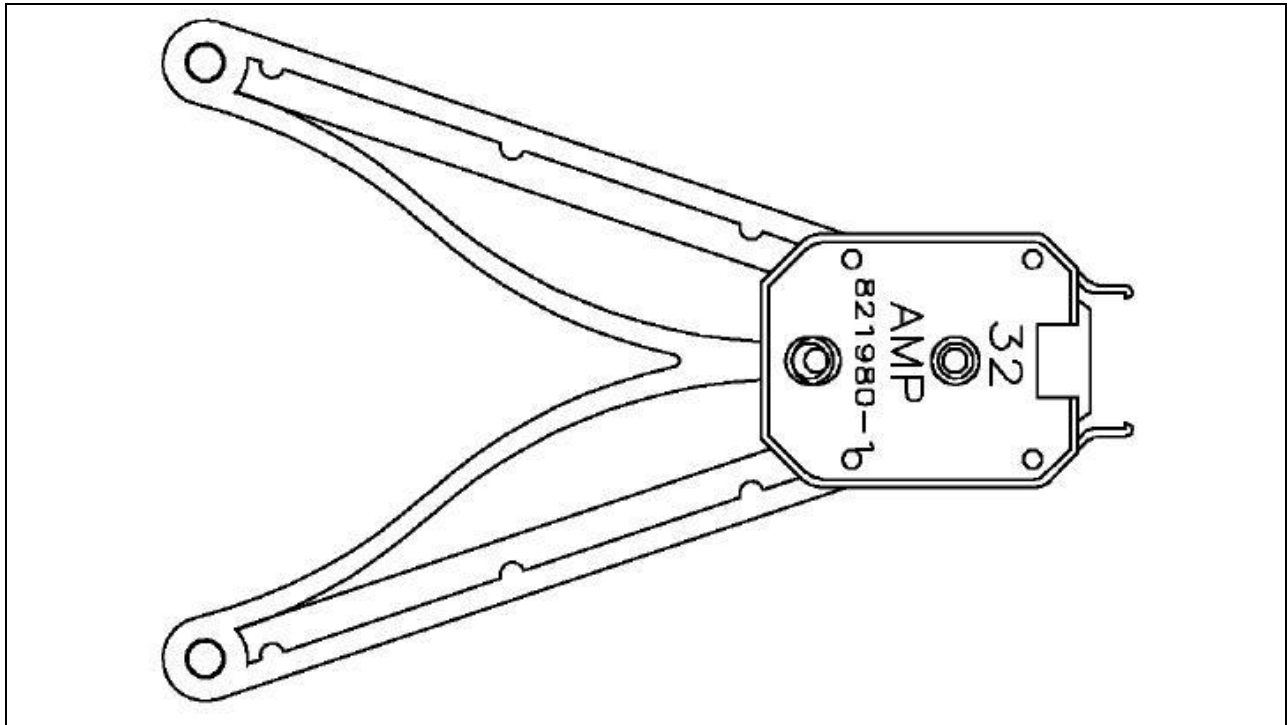

Figure 4-4. PLCC 32 Pin IC Terminal Extraction Tool

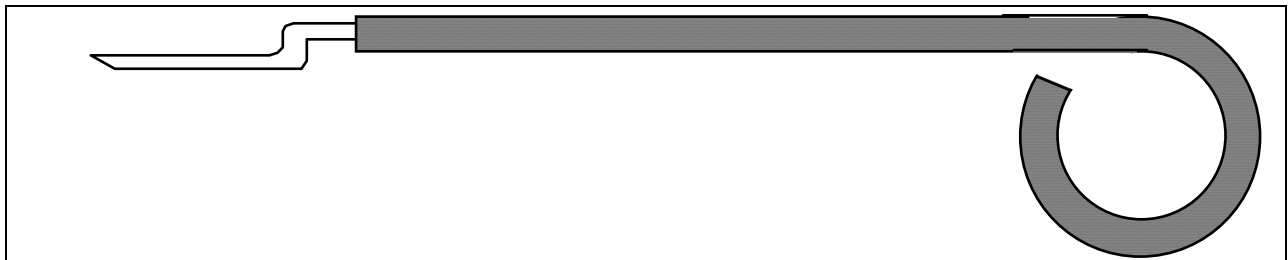

Figure 4-5. Terminal Extraction Tool, B Relay Terminal, P/N 59688-000-00

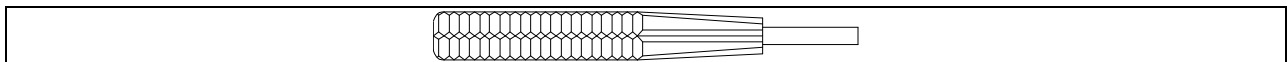

Figure 4-6. Terminal Extraction Tool, DIN Type F, P/N 59688-038-00



**FOR QUESTIONS AND INQUIRIES, CONTACT CUSTOMER SERVICE AT  
1-800-717-4477  
OR  
[WWW.ALSTOMSIGNALINGSOLUTIONS.COM](http://WWW.ALSTOMSIGNALINGSOLUTIONS.COM)**

**ALSTOM SIGNALING INC.  
1025 JOHN STREET  
WEST HENRIETTA, NY 14586**