



iVPI

Integrated
Vital Processor
Interlocking
Control System



Copyright © 2008, 2010 Alstom Signaling Inc.



iVPI

Integrated
Vital Processor
Interlocking
Control System



Copyright © 2008, 2010 Alstom Signaling Inc.

Product Overview Manual
Alstom Signaling Inc.

P2521A, Rev. April 2010, Printed in U.S.A.

LIST OF EFFECTIVE PAGES

P2521A, iVPI Integrated Vital Processor Interlocking Control System Product Overview Manual

ORIGINAL ISSUE DATE: October 2008

CURRENT REVISION AND DATE: April 2010, updated part numbers

PAGE	CHANGE OR REVISION LEVEL
Cover	Apr/10
Title page	Apr/10
Preface	Apr/10
i thru vi	Apr/10
1-1 thru 1-6	Apr/10
2-1 thru 2-16	Apr/10
3-1 thru 3-4	Apr/10
4-1 thru 4-14	Apr/10
5-1 thru 5-4	Apr/10
6-1 thru 6-20	Apr/10
7-1 thru 7-6	Apr/10
8-1 thru 8-2	Apr/10
9-1 thru 9-2	Apr/10
10-1 thru 10-2	Apr/10
A-1 thru A-4	Apr/10

THIS PAGE INTENTIONALLY LEFT BLANK.

PREFACE

NOTICE OF CONFIDENTIAL INFORMATION

Information contained herein is confidential and is the property of Alstom Signaling Incorporated. Where furnished with a proposal, the recipient shall use it solely to evaluate the proposal. Where furnished to customer, it shall be used solely for the purposes of inspection, installation or maintenance. Where furnished to a supplier, it shall be used solely in the performance of the contract. The information shall not be used or disclosed by the recipient for any other purposes whatsoever.

**FOR QUESTIONS AND INQUIRIES, CONTACT CUSTOMER SERVICE AT
1-800-717-4477
OR
WWW.ALSTOMSIGNALINGSOLUTIONS.COM**

**ALSTOM SIGNALING INC.
1025 JOHN STREET
WEST HENRIETTA, NY 14586**

REVISION LOG

Revision	Date	Description	By	Checked	Approved
1	October 2008	Original issue	MAS	NI	NI
2	April 2010	Added board Part Numbers, BEX and PTC	MAS	RH	CZ

THIS PAGE INTENTIONALLY LEFT BLANK.

ABOUT THE MANUAL

This manual is intended to introduce the Alstom Integrated Vital Processor Interlocking Control System, (iVPI).

The information in this manual is arranged into sections. The title and a brief description of each section follow:

Section 1 – GENERAL DESCRIPTION: This section describes the manual organization, introduces the topics covered, and provides a glossary of terms used in this manual.

Section 2 – SYSTEM ORGANIZATION: This section gives general information on function and organization of the iVPI System.

Section 3 – SUBRACK CONFIGURATION: This section describes the Subrack used for the iVPI System.

Section 4 – VITAL SUBSYSTEM: This section describes the Vital boards and assemblies used in the iVPI System.

Section 5 – NON VITAL SUBSYSTEM: This section describes the non -vital boards and assemblies used in the iVPI System.

Section 6 – DESIGN, TEST AND VALIDATION TOOLS: This section describes the design, test and validation tools used for the iVPI System.

Section 7 – NON-VITAL SYSTEM AND COMMUNICATIONS SOFTWARE: This section describes the non -vital System and communications software used in the iVPI System.

Section 8 – MIGRATION STRATEGIES: This section describes the migration strategies for migrating existing VPI[®] Systems to iVPI Systems.

Section 9 – REDUNDANCY, AVAILABILITY AND ISOLATION: This section describes the iVPI System redundancy, availability and isolation.

Section 10 – SUMMARY: This section summarizes the benefits of using the iVPI System.

Appendix A – HISTORY OF THE VPI PRODUCT LINE: This section describes the history and evolution of the VPI[®] product line.

THIS PAGE INTENTIONALLY LEFT BLANK.

MANUAL SPECIAL NOTATIONS

In the Alstom manuals, there are three methods used to convey special informational notations to the reader. These notations are warnings, cautions, and notes. Both warnings and cautions are readily noticeable by boldface type two lines beneath the caption.

Warning

A warning is the most important notation to heed. A warning is used to tell the reader that special attention needs to be paid to the message because if the instructions or advice is not followed when working on the equipment then the result could be either serious harm or death. The sudden, unexpected operation of a switch machine, for example, or the technician contacting the third rail could lead to personal injury or death. An example of a typical warning notice follows:

WARNING

DISCONNECT THE MOTOR ENERGY WHENEVER WORKING ON SWITCH LAYOUT OR SWITCH MACHINE. UNEXPECTED OPERATION OF MACHINE COULD CAUSE INJURY FROM OPEN GEARS, ELECTRICAL SHOCK, OR MOVING SWITCH POINTS.

Caution

A caution statement is used when an operating or maintenance procedure, practice, condition, or statement, which if not strictly adhered to, could result in damage to or destruction of equipment. A typical caution found in a manual is as follows:

CAUTION

Turn power off before attempting to remove or insert circuit boards into a module. Boards can be damaged if power is not turned off.

Note

A note is normally used to provide minor additional information to the reader to explain the reason for a given step in a test procedure or to provide a background detail. An example of the use of a note follows:

NOTE

A capacitor may be mounted on the circuit board with a RTV adhesive. Use the same color RTV.

THIS PAGE INTENTIONALLY LEFT BLANK.

TABLE OF CONTENTS

Topic	Page
1. SECTION 1 – GENERAL DESCRIPTION	1-1
1.1. GENERAL	1-1
1.2. SYSTEM TERMS	1-1
1.3. ACRONYMS AND ABBREVIATIONS	1-2
2. SECTION 2 – SYSTEM ORGANIZATION	2-1
2.1. GENERAL	2-1
2.2. EVOLUTION TO IVPI	2-1
2.3. IVPI INTERNAL ARCHITECTURE	2-1
2.4. IVPI GENERAL FUNCTIONS	2-2
2.5. COMPETITIVE BENEFITS OF IVPI SYSTEMS	2-3
2.6. IVPI GENERAL SPECIFICATIONS	2-5
2.7. VERSATILE APPLICATION SCENARIOS FOR IVPI	2-8
2.7.1. Freight Railroads	2-10
2.7.2. Commuter Rail Applications	2-12
2.7.3. Light Rail Applications	2-12
2.7.3.1. ATP Or Not	2-13
2.7.3.2. Place Equipment Where It Makes Sense	2-13
2.7.3.3. Pass Information Any Way Necessary	2-13
2.7.3.4. Integrate With Other LRT Specific Control Systems	2-13
2.7.4. Heavy Rail Transit Applications	2-14
2.7.4.1. Large Interlockings	2-14
2.8. IVPI ETHERNET CONNECTIVITY OVERVIEW	2-15
3. SECTION –3 SUBRACK CONFIGURATIONS	3-1
3.1. GENERAL	3-1
3.2. IVPI SUBRACK DESCRIPTION	3-1
3.3. BUS EXPANSION (BEX) BOARD	3-4
4. SECTION 4 – VITAL SUBSYSTEM	4-1
4.1. GENERAL	4-1
4.2. INTRODUCTION	4-1
4.2.1. Vital System Processor (VSP)	4-2
4.2.1.1. System Vital Communications	4-2
4.2.1.2. Logic Processor	4-3
4.2.1.3. System Verification	4-3
4.2.1.4. Vital Timing	4-3
4.2.2. Genrakode Track Processor (GTP)	4-5
4.2.3. Direct Input	4-6
4.2.4. iVPI Vital Output Board Descriptions	4-7
4.2.4.1. Single Break Output	4-7
4.2.4.2. Double Break Output	4-9
4.2.4.3. Lamp Drive Output	4-10

TABLE OF CONTENTS (CONT.)

Topic	Page
4.2.4.4. AC Output.....	4-12
4.2.4.5. Code Rate Generator.....	4-13
5. SECTION 5 – NON-VITAL SUBSYSTEM.....	5-1
5.1. GENERAL.....	5-1
5.2. INTRODUCTION.....	5-1
5.3. INDIVIDUAL IVPI NON-VITAL BOARD DESCRIPTIONS.....	5-2
5.3.1. Non-Vital System Processor.....	5-2
5.3.2. Non-Vital Input.....	5-4
5.3.3. Non-Vital Output.....	5-4
6. SECTION 6 – DESIGN, TEST AND VALIDATION TOOLS.....	6-1
6.1. GENERAL.....	6-1
6.2. INTRODUCTION.....	6-1
6.3. APPLICATION DEVELOPMENT TOOL.....	6-2
6.3.1. CAAPE Operation.....	6-5
6.3.2. Application Data Verification (ADV) and ADV Comparison.....	6-6
6.3.3. Graphical Simulator – Integrated and Provided With the CAAPE Package.....	6-8
6.3.4. AlsDload.....	6-10
6.3.5. CAAPE System Benefits.....	6-11
6.3.6. CAAPE System Requirements.....	6-12
6.4. MAINTENANCE MANAGEMENT SYSTEM (MMS).....	6-13
6.4.1. Introduction.....	6-13
6.4.2. MMS Fault Detection.....	6-14
6.4.3. MMS Logging.....	6-14
6.4.4. MMS Graphical User Interface.....	6-14
6.4.5. MMS Graphical System Diagnostics.....	6-15
6.4.6. MMS Application Explorer.....	6-16
6.4.7. MMS Configuration Manager.....	6-17
6.4.8. Communication Explorer – VT 100 Screen.....	6-18
6.5. EMBEDDED DATALOGGER.....	6-19
7. SECTION 7 – NON-VITAL SYSTEM AND COMMUNICATIONS SOFTWARE .	7-1
7.1. GENERAL.....	7-1
7.2. INTRODUCTION.....	7-1
7.3. APPLICATION.....	7-2
7.3.1. I/O.....	7-2
7.3.2. Logic.....	7-3
7.3.2.1. Logic Statement Types.....	7-4
7.3.3. Communications.....	7-5
7.4. SYSTEM SOFTWARE INTERFACE MATRIX.....	7-5

TABLE OF CONTENTS (CONT.)

Topic	Page
8. SECTION 8 – MIGRATION STRATEGIES	8-1
9. SECTION 9 – REDUNDANCY, AVAILABILITY AND ISOLATION	9-1
9.1. GENERAL	9-1
9.2. REDUNDANCY	9-1
9.3. AVAILABILITY	9-1
9.4. ISOLATION	9-1
10. SECTION 10 – SUMMARY	10-1
A. APPENDIX A – HISTORY OF THE VPI PRODUCT LINE	A-1
A.1. GENERAL	A-1
A.2. INTRODUCTION	A-1
A.3. VPI OPERATING CONDITIONS	A-3

LIST OF FIGURES

Description	Page
Figure 2–1. Overall Architecture, iVPI-Based Interlocking.....	2–1
Figure 2–2. Example iVPI Vital / Non-Vital System Application.....	2–9
Figure 2–3. Example iVPI Expansion System Application.....	2–10
Figure 2–4. Independent Ethernet Backbones Vital Devices Separate From Non-Vital Devices	2–16
Figure 2–5. Redundant Ethernet Backbones Supporting Vital And Non-Vital Devices.....	2–16
Figure 3–1. 21-Slot iVPI Subrack Filled.....	3–2
Figure 3–2. IO Bus Expansion Board LEDs	3–4
Figure 4–1. VSP Board	4–4
Figure 4–2. Genrakode Track Processor Board	4–5
Figure 4–3. Direct Input Board	4–6
Figure 4–4. Single Break Output Board.....	4–8
Figure 4–5. Double Break Output Board	4–9
Figure 4–6. Lamp Driver Output Board	4–11
Figure 4–7. AC Output Board.....	4–12
Figure 4–8. Code Rate Generator Board	4–13
Figure 5–1. NVSP Board.....	5–3
Figure 5–2. NVO Board.....	5–4
Figure 6–1. iVPI / VPI CAAPE/CAA Typical Arrangement	6–3
Figure 6–2. CAAPE Relay Application Logic Display (Depicting AREMA Drop Line Symbols)	6–5
Figure 6–3. Graphical ADV – Compares Logic Input to Output Files With CRCs.....	6–7
Figure 6–4. ADV Comparison Report Depicting Expression Changes on a Boolean Expression.....	6–7
Figure 6–5. Graphical Simulator Application Logic Display	6–9
Figure 6–6. Graphical Simulator Track Plan Display (Depicting Interlocking Control And GENRAKODE Codes).....	6–9
Figure 6-7. Maintenance Management System (MMS).....	6–14
Figure 6–8. MMS Graphical System Diagnostics	6–15
Figure 6–9. MMS Application Explorer (Depicting PLC Ladder Logic Symbols).....	6–16
Figure 6–10. MMS Configuration Manager	6–17
Figure 6–11. MMS Runtime, Communication Explorer – VT100 Screen.....	6–18
Figure 7–1. Logic Programming Sample	7–4
Figure A–1. Continuous Evolution of VPI®	A–2

LIST OF TABLES

Description	Page
Table 1–1. Glossary	1–2
Table 2–1. iVPI Specifications.....	2–5
Table 2–2. iVPI Board Part Numbers	2–6
Table 3–1. Plug Coupled Subrack Part Numbers.....	3–3
Table 6–1. Design Test and Validation Tool Part Numbers.....	6–1
Table 6–2. CAAPE System Requirements	6–12
Table 7–1. Communications Protocol Library.....	7–5

THIS PAGE INTENTIONALLY LEFT BLANK.

1. SECTION 1 – GENERAL DESCRIPTION

1.1. GENERAL

This document contains a general description of the Alstom iVPI Vital Processor Interlocking Control System. It contains basic, system level information, and hardware descriptions and is intended to be used to estimate the items required to satisfy a specific interlocking's control requirements.

CAUTION

Be aware this manual is not intended as an Application or Operation and Maintenance manual.

Detailed information for applying and configuring an iVPI System is available in the iVPI Installation, Operations and Maintenance Manual P2521B volumes 1 through 5, the Computer-Aided Application Programming Environment Software Package CAAPE User's Manual P2512A, and the Integrated Vital Processor Interlocking (iVPI) Computer Aided Application (CAA) Reference Manual P2512F.

1.2. SYSTEM TERMS

The iVPI System is highly modular in design, implemented in one or more Subracks with a set of plug-in eurocard style printed circuit boards that are applied in varying quantities to meet the needs of specific applications.

The terminology used to define the Subrack and its components is as follows:

- A Subrack is a Chassis with Motherboard
- A System is one or more Subracks filled with the appropriate boards for the application
- When a System is configured with more than one Subrack populated with boards, the individual populated Subracks are Subsystems

1.3. ACRONYMS AND ABBREVIATIONS

Terms and abbreviations used throughout this manual are provided in Table 1–1.

Table 1–1. Glossary

Term	Definition or Explanation
ACO	Vital AC Output board
ADV	Application Data Verifier
AF	Audio Frequency
AlsDload	A tool for programming application and system software on VPI, WIU, iVPI, and PGK boards
AOCD	Absence Of Current Detector
AREMA	American Railway Engineering and Maintenance of Way Association
ARES	Advanced Railroad Electronic System
ATC	Automatic Train Control
ATCS	Automatic Train Control System
ATO	Automatic Train Operation
ATP	Automatic Train Protection
BEX	Bus Expansion board
CAA	Computer-Aided Application
CAAPE	Computer-Aided Application Programming Environment
Chassis	The hardware case; it becomes a Subrack when the Motherboard is installed and a System or Subsystem when populated with boards
CIC	Cable Integrity Check
CMOS	Complementary Metal-Oxide-Semiconductor, a major class of integrated circuits; CMOS devices use little power and do not produce as much heat as other forms of logic
Compiler	Program that translates a high-level computer language into machine language
CPU	Central Processing Unit – the computer section that handles the actual processing of data into information
CRC	Cyclical redundancy Checks
CRG	Code Rate Generator board
DBO	Double Break Output board

Table 1–1. Glossary (Cont.)

Term	Definition or Explanation
Diagnostic	The process of detection and isolation of either a malfunction or mistake
Diagnostic Routine	A routine designed specifically to locate a malfunction in the computer
DI	Direct Input board
EIA	Electronic Industries Alliance
EMI	Electromagnetic Interference
EPROM	A programmable read-only memory device that is erasable using high intensity ultra-violet light
Failsafe	The concept that if a system fails only a safe result will occur
Firmware	Instructions stored on a ROM chip
FLASH	A form of electrically erasable programmable read only memory used with embedded processors
FPGA	Field Programmable Gate Array
FRA	Federal Railroad Administration
GTP	Genrakode Track Processor
Hardware	The electronic section of the computer that stores and manipulates symbols under the direction of the computer
HMI	Human Machine Interface
I ² C	Inter-Integrated Circuit
I/O	Input/Output
iVPI	Alstom's integrated Vital Processor Interlocking product
Interface	The equipment that enables one kind of hardware to be recognized and processed by another kind of hardware
Latch	A mode of operation for a circuit in which an output's state is maintained
LDO	Lamp Drive Output board
LRT	Light Rail Transit
MAC	Maintenance Access connection point in a system. This enables the connection of a VT100 compatible terminal to examine system diagnostics and internal operation of the system
MMS	Maintenance Management System
Modem	A piece of equipment that connects data terminal equipment to a communication line

Table 1–1. Glossary (Cont.)

Term	Definition or Explanation
MODBUS	A messaging structure used to establish master-slave/MODBUS/TCP communication between intelligent devices
MUX	Multiplexer
NISAL	Numerically Integrated Safety Assurance Logic
Non-Vital	A component or function that is not critical to safety, its failure is not considered critical to the safe operation of a railroad but may be significant operationally
NVI	Non-Vital Input board
NVO	Non-Vital Output board
NVSP	Non-Vital System Processor board
PCB	Printed Circuit Board (board)
POR	Power On Reset
Program	A series of instructions for the computer to follow
PROM	Programmable Read-Only Memory – programmable memory devices that store firmware
PTC	Positive Train Control
RAM	Random Access Memory – this part of memory temporarily stores information that is constantly being changed in the computer; here, words may be stored (written) or read (retrieved) in any order at random
REDP	Relay Equivalent Drawing Package
Reset	The act of changing a bit value to zero or an output to an inactive condition. Also refers to the startup or restart of a processor-based system
ROM	Read-Only Memory – this part of memory is built in during the integrated circuit fabrication process; ROM content cannot be altered after the chip is produced
RTU	Relay Test Unit
SBO	Single Break Output board
SCADA	Supervisory Control And Data Acquisition
Simulator	A special program that represents the behavior of a system
SMT	Surface Mount Technology
Software	Programs that direct the activity of the computer
Subrack	Chassis with Motherboard; it becomes a System or Subsystem when populated with boards

Table 1–1. Glossary (Cont.)

Term	Definition or Explanation
Subroutine	A section of a program that carries out a specific operation
Subsystem	Used to summarize the Vital or non-vital functions of an iVPI System, as in Vital Subsystem and non-vital Subsystem
Subsystem (iVPI)	One of multiple Subracks populated with boards in a System configuration composed of more than one Subrack
System (iVPI)	One or more Subracks populated with boards
Task	A program that is run as an independent unit
TTL	Transistor-Transistor Logic
TWC	Train-to-Wayside Communications
VRD	Vital Relay Driver board
VSC	Vital Serial Controller board that provides a means for exchanging the states of Vital interlocking functions between interlocking systems in a Vital manner
VSOE	Vital Serial Over Ethernet
VSP	Vital System Processor board
Vital Component or Circuit	Any device, circuit or software module used to implement a Vital function; a Vital circuit is so named because its function is critical to the operation of certain signals and track equipment
Vital Function	A system, subsystem, equipment or component that provides a function critical to safety; it is implemented using failsafe design principals, hardware, software and/or relays
w/o	Without
WIU	Wayside Interface Unit

THIS PAGE INTENTIONALLY LEFT BLANK.

2. SECTION 2 – SYSTEM ORGANIZATION

2.1. GENERAL

This section describes the organization of the iVPI System.

2.2. EVOLUTION TO iVPI

First introduced in 2007, the iVPI version of the VPI family offers the newest upgrades in electronics packaging and the latest in surface mount technology (SMT). iVPI Systems maintain the usage of the same Vital hardware designs and Vital software algorithms as the earlier generations of the VPI family. Like the previous generations of the VPI family, iVPI is functionally compatible with previous versions of the family and is designed for long life cycle support and upgrades.

2.3. iVPI INTERNAL ARCHITECTURE

Alstom's integrated Vital Processor Interlocking (iVPI) System seamlessly integrates Vital and non-vital functions, including Vital and non-vital communications. Adding in the Ethernet networking capability, iVPI can communicate with up to 40 Systems using the Vital Serial Over Ethernet (VSOE) protocol. The overall general iVPI product architecture is shown diagrammatically in Figure 2–1.

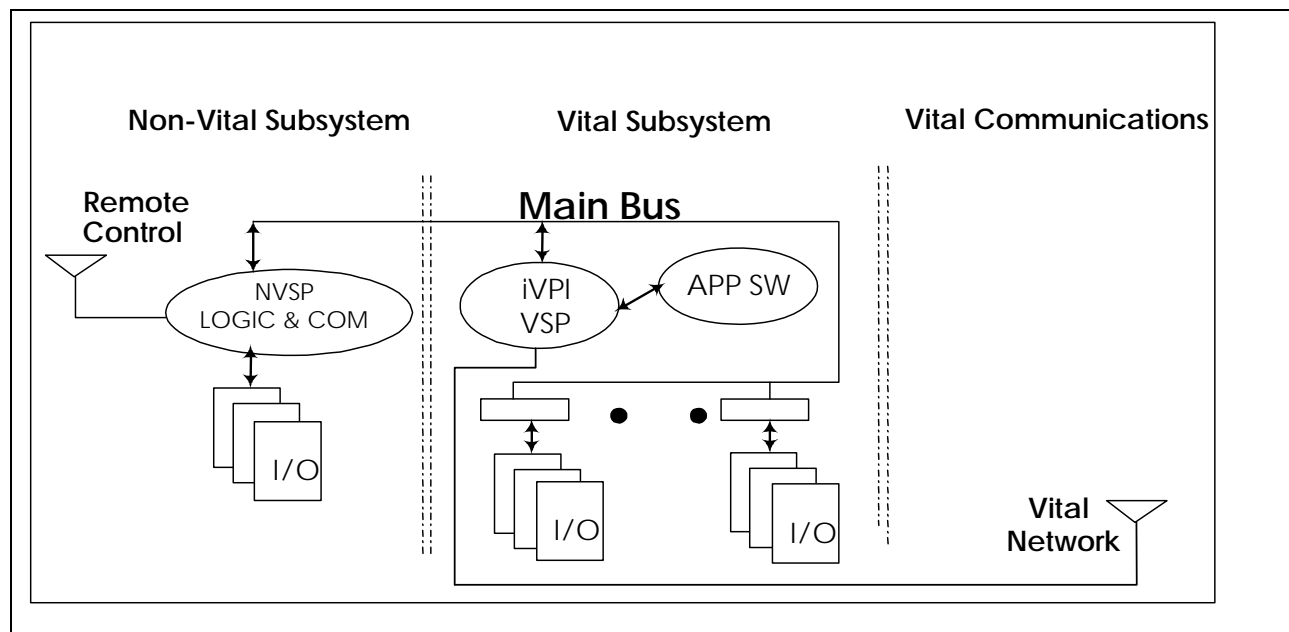

Figure 2–1. Overall Architecture, iVPI-Based Interlocking

2.4. IVPI GENERAL FUNCTIONS

The Interlocking subsystem provides the Vital failsafe interface with the signaling Field Equipment. The electronic interlocking is Alstom's integrated Vital Processing Interlocking (iVPI) control system.

The iVPI control system consists of a:

- Failsafe Vital System Processor (VSP) with integrated Vital network communications adapter supporting VSOE, other Vital protocols and the Alstom Maintenance Management System (MMS).
- Family of Failsafe Vital I/O to/from remote signaling devices and Vital field apparatus such as switch machines, train stops, track circuits, signal lamps and LED arrays, highway crossing equipment, cab signaling equipment, and more.
- Where required by market, integrated Genrakode Track Processor (GTP) for direct interface at control points to the coded track circuits. Other integrated Track Circuit functions are possible.
- Integrated Code Rate Generator (CRG) for generating the speed command pulses used to modulate the carrier frequency (for example, 60 Hz) for track circuits within the interlocking plant and at the interlocking end of the approach track circuits
- Non-Vital System Processor (NVSP) interface with the Control System with integrated Ethernet TCP/IP, synchronous, and asynchronous communication channels capable of simultaneously supporting multiple communication protocols and MMS.
- Family of Non-vital I/O to interface with non-vital signaling apparatus such as Local Control Panels, Intrusion alarms, non-vital train inspection equipment, and more.

2.5. COMPETITIVE BENEFITS OF IVPI SYSTEMS

- Scalability / Modularity - iVPI Systems can be arranged in many user programmable system configurations ranging from:
 - Fully centralized logic and I/O; to
 - Centralized logic with remote I/O and object controllers; to
 - Fully distributed self-standing systems.

This aspect is a key benefit of the iVPI System that moves it ahead of the competition.

- Network Interfaces – the iVPI platform provides improved integration with transparent interface to radio offerings, providing Vital and non-vital communications to fit the need of the application. Included in the networking improvements is the addition of Ethernet connectivity, which is described in greater detail in section 2.8.
- System Maintainability – iVPI brings many savings in the maintenance arena, including the:
 - Inclusion of “health status” monitors on the front panel of each board, simplifying and reducing maintenance time,
 - Elimination of wire wraps eliminates potential rewiring expense, Vital I/O headers and Signature PROMS,
 - Eurocard 9U Subrack and surface mount boards reduce potential future obsolescence issues, and
 - Electronic revision configuration control simplifies the new FRA compliance rules.
- Plug & Play Capability – only two boards in the new iVPI Subrack require a specific slot location. The VSP board is a double wide board assigned to slots 1 and 2. The single slot wide NVSP board can be assigned to any of slots 3 through 8. Any other board used in the System may be plugged into any slot other than 1 or 2 without fear of damaging the boards or Subrack while reducing both setup and restore time as well as maintenance requirements.
- Compatibility – the new iVPI platform is fully compatible with previous versions of the VPI family, and is designed for long life cycle support and upgrades.

- Redundant vs. Non-Redundant - iVPI Systems can operate with no redundancy while providing extremely high reliability and availability to System and Subsystem arrangements with redundant pairs to provide hot standby and automatic failover.
- System Testing - the iVPI VSP board has both a Communications processor as well as a Main processor with separate application programming that minimizes retesting. Minimal retesting results in lower System serviceability and maintainability requirements which equate to lower System costs.
- System Safety – the iVPI platform is based on the proven VPI and Genrakode safety design case that includes a MTBHE (Mean Time Between Hazardous Events) of better than 10^{13} hours and a history of zero safety incidents.
- Spares – smaller Systems with fewer boards result in lower spares requirements. Reducing the costly rack mounted power supplies (by moving the power supplies directly to each System board) results in further reductions to spares inventory.

Further spares reductions are gained when a System uses the Genrakode Track Processor (GTP) board for track circuit control. iVPI integrates this functionality into one System, alleviating the previously required Genrakode module and boards.

- Application Software Changes – through use of the CAAPE tool, the engineer or maintainer can download software and verify CRCs directly to the VSP and NVSP boards. There is no need for external PROM burners or PC RS323 converter devices.

2.6. IVPI GENERAL SPECIFICATIONS

Table 2–1 lists the nominal specifications for the iVPI System [Subrack(s) and boards]. Additional board voltages can be supported as required by specific applications. It is to be understood that iVPI represents a generic platform that can be used in Freight, Commuter, Light Rail and Heavy Rail Transit applications.

Table Table 2–2 lists the boards used in the iVPI System. A system can be configured with up to 10 system type boards (CRG, GTP, VSP).

Table 2–1. iVPI Specifications

Product Characteristics	Alstom iVPI (Typical per System)
Number of Track Circuits Supported by GTP	Up to 20 track circuits per System, 2 track circuits per GTP, 10 boards per System
Maximum Track Circuit Length Supported by GTP	24,000 feet @ 3 ohms per 1,000 feet ballast non-electrified territory
Lamp Control	8 outputs per board
Cab Signal Generator Controls	8 outputs per board; maximum 3 boards per System
Operating Voltages	9 to 16 VDC (RR and Transit) and 16 to 36 VDC (Transit and International)
Networking Capability	VSP has 2 Ethernet Device Interfaces for connectivity of up to 40 nodes using the VSOE protocol plus MMS NVSP has 2 Ethernet Device Interfaces that support up to 10 TCP/IP connections plus MMS
Scalability	Control of a single switch point to a complex interlocking
Recorder Logging Capability	Approximately 50,000 events, expandable to > 100,000
Graceful Degradation	Achievable between interlocking control and track circuits through system partitioning
Vital Inputs / Outputs	8 outputs per board; maximum 40 boards per System, 320 ports 16 inputs per board; maximum 20 boards per System, 320 ports
Non-Vital Inputs/Outputs	32 inputs per board 32 outputs per board 20 boards per system

Table 2–2. iVPI Board Part Numbers

Board Type	Drawing Number	Comments
Vital System Processor (VSP)	31166-427-01	386 Processor, 2 Ethernet, I-O Bus Interf, Vital Relay Driver Operate 9-15 VDC, Vital Sftw 40025-413-00/ Boot 40025-426-00, Comm Sftw 40025-416-00/Boot 40025-417-00, (VPICAA -600 Series)
Direct Input (DI)	31166-429-01	Low Pass Filter, In 9-16 VDC, Differential, 16-High/Low True
Direct Input (DI)	31166-429-02	DI, Momentary In-Hold DCAP, In 9-16 VDC, Differential, 16-High/Low True
Single Break Output (SBO)	31166-430-01	Supply 9-30 VDC, Source Out = [Supply- $\text{typ } 1 \text{ VDC}$], 0.5 Amp operation, 8-Ports
Double Break Output (DBO)	31166-433-01	Supply 9-15V, Out = [Supply- $(5 \cdot \text{outAmp})$], 0.6 Amp, 8-Ports
Lamp Driver Output (LDO)	31166-431-01	Supply 9-18 VDC, Source Out = [Supply- $\text{typ } 1 \text{ VDC}$], 3.3 Amp, Hot & 100mA Cold Check, Cable Integrity Chk, Over/Low Current Monitor, 8-Ports
Vital AC Output (ACO)	31166-432-01	Supply 90-130 VAC, ACcom Out = [Supply], 0.8 Amp, 40-150Hz, 8-Ports, Higher EMI Protection
Code Rate Generator (CRG)	31166-459-01	Sftw 40025-438-01, Code Rates: 0, 50, 75, 120, 180, 270, 420, Steady-On, Solid State Driver, 10 Brd/Sys, VPICAA -600
Code Rate Generator (CRG)	31166-459-02	Sftw 40025-438-01, Code Rates: 0, 50, 75, 120, 180, 270, 420, Steady-On, Relay Driver, 10 Brd/Sys, VPICAA -600
Genrakode Track Processor (GTP)	31166-434-01	Sftw 40025-xxx-00, 2-Genrakode DC Track Circuits w/o Ethernet Software, CAA -0xx, up to 24,000 feet @ 3 ohms per 1,000 feet ballast non-electrified territory
Non-Vital System Processor (NVSP)	31166-428-01	386 Processor, NV Sftw 40025-418-00/ Boot 40025-419-00, Comm Sftw 40025-420-00/ Boot 40025-421-00 (w/4, 01169-767-ON, 29F040), 3 Comm Ports, 2 Ethernet
Non-Vital Input (NVI)	31166-457-01	In 18-36 VDC, 32-Differential Input w/Diagn
Non-Vital Input (NVI)	31166-457-02	In 9-18 VDC, 32-Differential Input w/Diagn

Table 2–2. iVPI Board Part Numbers (Cont.)

Board Type	Drawing Number	Comments
Non-Vital Output (NVO)	31166-458-01	Out, 16-Form A, 16-Form C, 0-35 V AC/DC, 0.5 Amp operation, Power On Reset w/Diagn (NVO-RELAY)
Non-Vital Output (NVO)	31166-458-02	Out, 32-SSR, 0-35 V AC/DC, 0.25 Amp Operation, Power On Reset w/Diagn (NVO-SSR)
Bus Expansion (BEX)	31166-460-01	BEX, Bus Expansion Board

2.7. VERSATILE APPLICATION SCENARIOS FOR IVPI

Compared to other solutions, with iVPI's wide range of scalability and interconnectivity, there is greater flexibility to deploy signaling components in a way that facilitates greater savings. This ranges from smaller room arrangements, to use of small cases where larger rooms were once required, to the placing of the control functions closer to the device being controlled saving on cable costs.

This new approach, made possible by reducing the form factor of the Vital and non-vital hardware and the use of network connectivity makes it possible to provide a "best fit" solution to all types of signaling applications. Actual hardware and software elements are described in detail later in the document.

Figure 2–2 is block diagram of an example iVPI application using every board type available for the iVPI System. Figure 2–3 is an example iVPI using the expansion system.

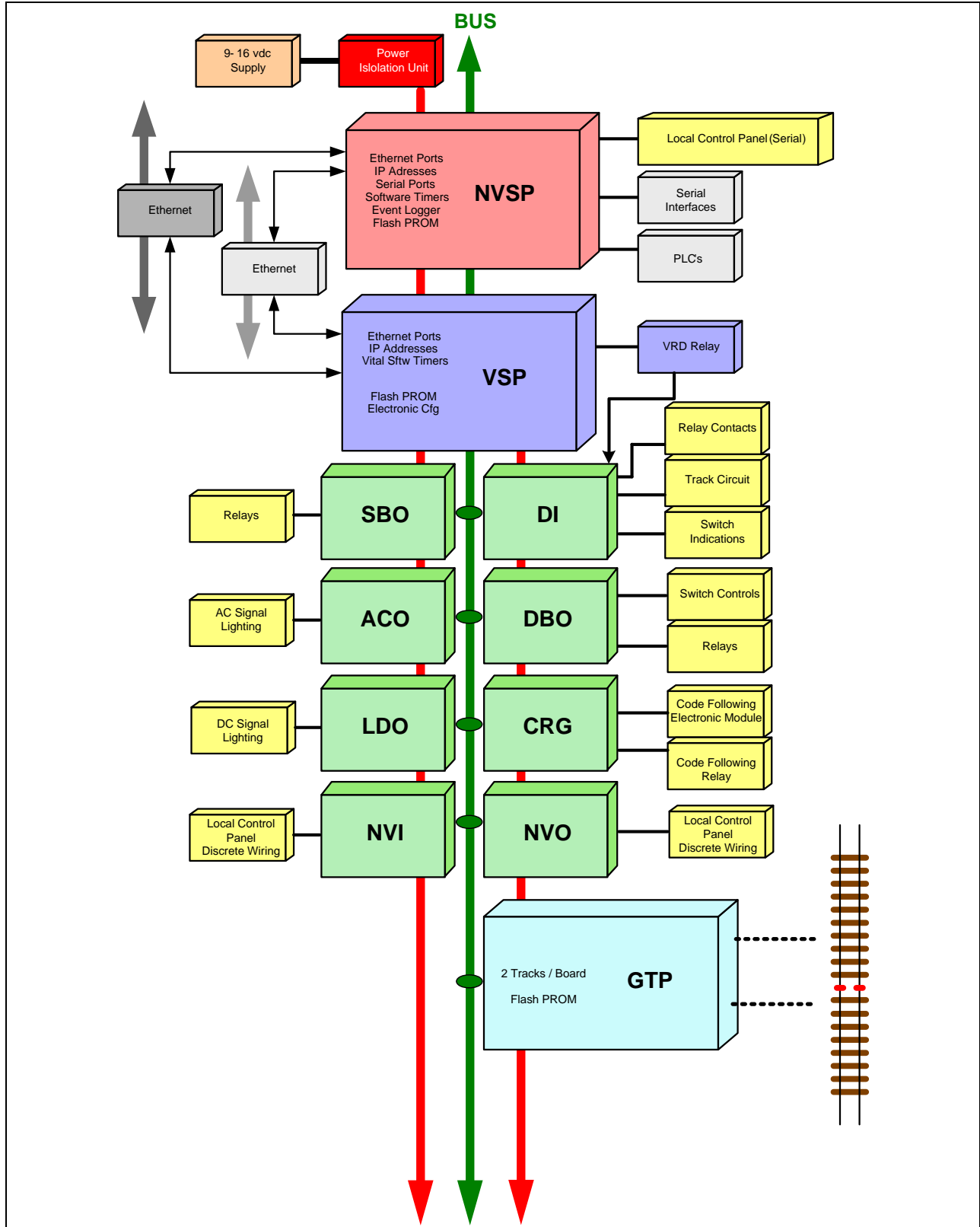

Figure 2–2. Example iVPI Vital / Non-Vital System Application

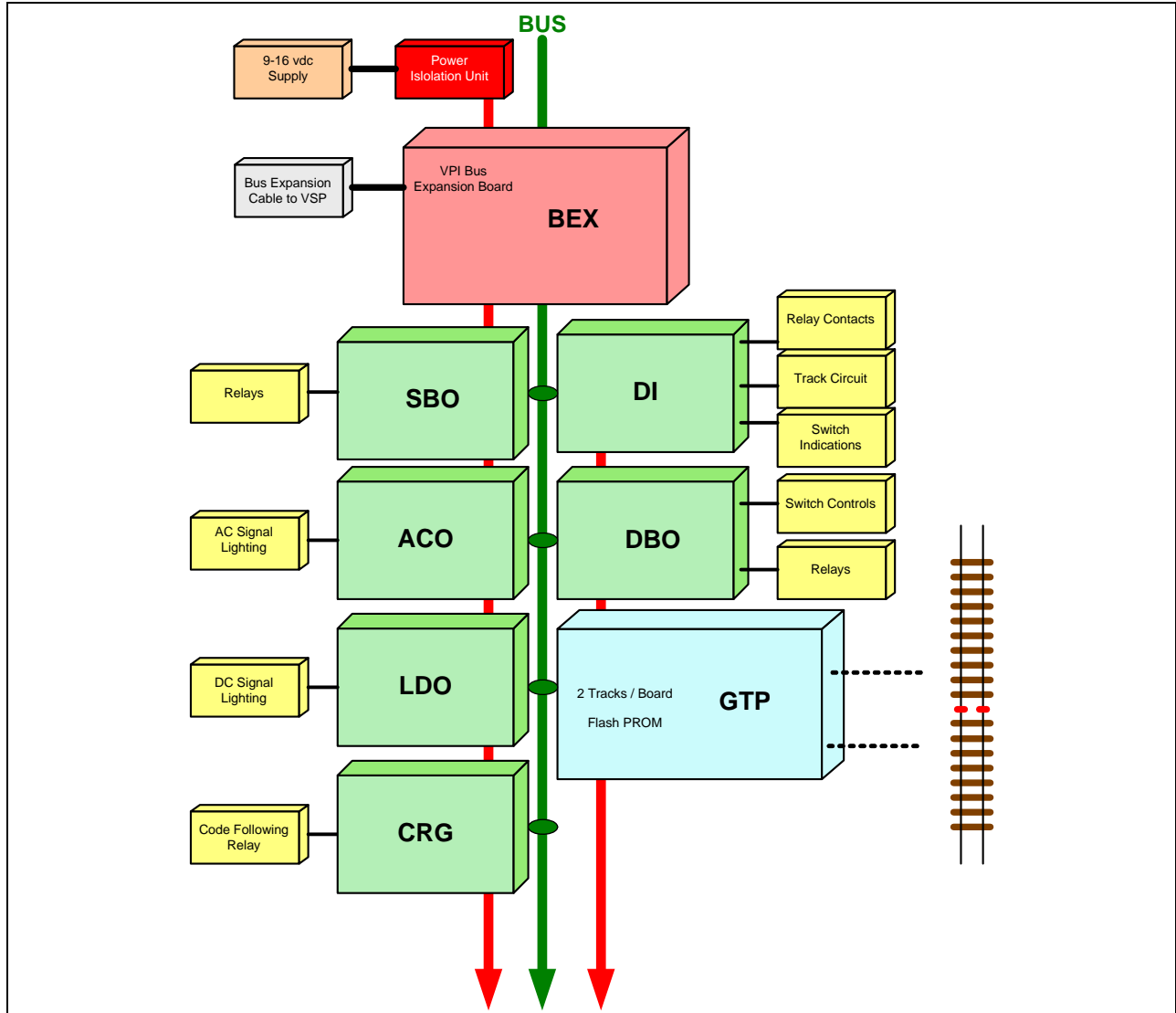

Figure 2–3. Example iVPI Expansion System Application

2.7.1. Freight Railroads

The interlocking function for traditional block signaling applications generally requires a combination of:

- Power supply for interlocking
- Signaling logic (Vital and non-vital)
- Local emergency control
- Communications to a central office with an industry standard protocol

- Local signal and switch machine interfaces
- Local track occupancies and approach track circuits using DC Coded track circuits
- Vital disconnect of load power in case of a safety critical failure

With iVP,I this is accomplished by the use of one electronics system containing:

- A Vital interlocking processor with signaling logic and network connections (Ethernet) to other Systems and MMS diagnostics for 24/7 troubleshooting
- A non-vital processor (if required) for non-vital logic, event recording, local emergency control, interface to CTC, or other including network interfaces for intra-system communications, MMS diagnostics for 24/7 monitoring and event log uploads
- Vital I/O to drive switch and signal and other Vital equipment
- An integrated track circuit for providing full track circuit functionality
- Non-Vital I/O as needed through the use of third party I/O systems with a serial link and/or Ethernet to the non-vital processor or non-vital I/O boards
- Power from the local signaling batteries is provided directly to the iVPI System with no intermediate power supply elements
- A Vital 'B' relay is provided to deliver energy feeds for Vital output circuits in absence of any safety critical failures; backs of the relay are used to light red aspects should a failure occur
- Capable of providing status of all interlocking inputs to the Positive Train Control (PTC) network, and optionally receiving code line (non-vital office request) inputs from the PTC network.

This hardware configuration can be easily contained in small rack or case (one control System), supplied with customer pre-engineered application logic rules and ordered under one part number.

2.7.2. Commuter Rail Applications

In North America Commuter Rail Lines, equipment used is that of Freight lines with added cab signaling equipment. For this application, the incremental requirements for the interlocking are:

- Cab signal rate codes assigned per track within the interlocking as well as on approach track circuits
- Freight requirements as noted previously

For iVPI, Commuter Rail use, the incremental functions to be included within the electronics system are:

- An integrated track circuit for providing full track circuit functionality
- A rate code generator which has outputs that can be coded at any of the standard NA and Freight rates.
- For Full Commuter rail applications including intermediate/adjacent track circuits, the same track circuit function as integrated within iVPI electronic system is used in a standalone mode along with a cab signal system to deliver coded rates to the rails.

2.7.3. Light Rail Applications

Light Rail applications can take two forms; one where trains run on traditional Freight lines and others that are more like street level trams. For Freight based lines, the requirements are still fulfilled and may or may not include cab signaling or other ATP functions. The requirements represent a superset of those items generally required and provided for with iVPI.

For Systems that mimic a transit orientation, iVPI can integrate many different functions depending on the requirements and type of system desired. This includes functionality for:

- Interfaces to Automatic Train Protection (ATP) Systems, both for train detection and including several levels of cab signaling. ATP logic is resident within the same processor as the signaling logic for the interlocking
- Formation of small Vital control elements using the same hardware and software that can be located centrally to a wayside control room (or case) or distributed along the right of way
- Ease of integration with supplier specified non-vital control systems where required to perform local supervisory control, routing functions, or Train to Wayside Communication (TWC) functions.

2.7.3.1. ATP Or Not

iVPI has the interfaces identified previously as well as an interface through the network to Audio Frequency and Digital track circuits where another form of ATP is required. The network interface allows the track circuits to be located in the main equipment room or distributed along the right of way to minimize the use of extended and costly to add cable runs.

2.7.3.2. Place Equipment Where It Makes Sense

Also along this line of interconnect, iVPI can be architected to place the location logic resident within the Vital and/or non-vital processors in an equipment house or case and the I/O can be located within the same room or placed at the location of the device to be controlled. This also provides the benefits of cable savings as well as having the remote functions be self sufficient from a safety perspective. That is, the remote functions have their own Vital checking function. This provides a very high level of availability, as a failure to a remote function does not effect the overall location.

2.7.3.3. Pass Information Any Way Necessary

Along with the Light Rail Transit (LRT) application of iVPI come software and hardware interfaces to support Vital and non-vital communications via network over fiber, radio or direct wire. An iVPI unit can communicate location-to-location, location to control center or location to train in a bidirectional manner.

2.7.3.4. Integrate With Other LRT Specific Control Systems

For applications that require the use of a third party non-vital control system for local emergency control or train routing, iVPI has standard interfaces to communicate status and control data using industry standard protocols such as Modbus and Modbus/TCP or TWC for routing.

2.7.4. Heavy Rail Transit Applications

Based on a wide portfolio of processing and I/O functions (boards), iVPI can be easily applied to NA Metro/Transit applications. Capacity is no issue as one iVPI System can manage an interlocking from 1 to 40 switch machines for example while at the same time processing all non-vital logic and communications and interfaces to ATC subsystems.

Available tools and hardware portfolio permit the ability to apply iVPI to:

- Fixed block signaling for interlockings including integrated ATC (cab Signaling) Logic
- Extensive wayside ATS functions such as driving local hard wired panels, ATO functions such as station stopping and dwell, SCADA type functions, and HMI workstations
- Vital and non-vital communications over wire, fiber or radio
- Local or remote diagnostics and event recording
- Network interface with AF Track circuits or Digital Track Circuits to provide speed commands or temporary speed commands to the vehicle through the rails

2.7.4.1. Large Interlockings

The iVPI portfolio of hardware, software and tools (design and maintenance) is well suited to manage:

- A small Vital or non-vital control function with one or two boards
- A medium location with over 40 switch machines and associated signals controlled by a single iVPI System
- A large location with 100s of switch machines and associated signals controlled by multiple iVPI Systems or with a control logic processor

The scalability of iVPI allows this simply by adding the necessary I/O, Serial and/or Ethernet interfaces. An iVPI System can expand from one control Subrack to four Subracks as required for centralized equipment rooms or simply partition into a standalone System as needed. A total of 640 Vital and 640 non-vital I/O points can be managed directly under the control of each Vital and non-vital processor (when configured as one complete System) or expanded greater with interconnected systems using Ethernet for a distributed approach.

2.8. IVPI ETHERNET CONNECTIVITY OVERVIEW

Each of the iVPI processor cards (both Vital and Non-Vital) contains two Ethernet devices (media types 10/100 BaseT, IEEE 802.3i and 802.3u respectively) that can be configured in independent or redundant networks. This allows Vital and non-vital messages to be mixed on the same network or to be kept independent from each other on a separate network.

Each device also supports multiple node connections and protocols. Using the Vital Serial over Ethernet (VSOE) Communications, the two devices on the Vital Serial Processor (VSP) board can handle up to 40 VSOE connections to other iVPI Systems. These can be split as redundant connections with half the total on one device, the other half on another device. One PC based Maintenance Management System (MMS) connection is also provided.

The Non-Vital Serial Processor (NVSP) board has similar capabilities that service office communications protocols (serially and/or Ethernet) and MMS connections. Both boards could share the same network if there is sufficient bandwidth.

An example of independent and redundant Ethernet backbones can be seen in Figures 2-4 and 2-5.

System Organization

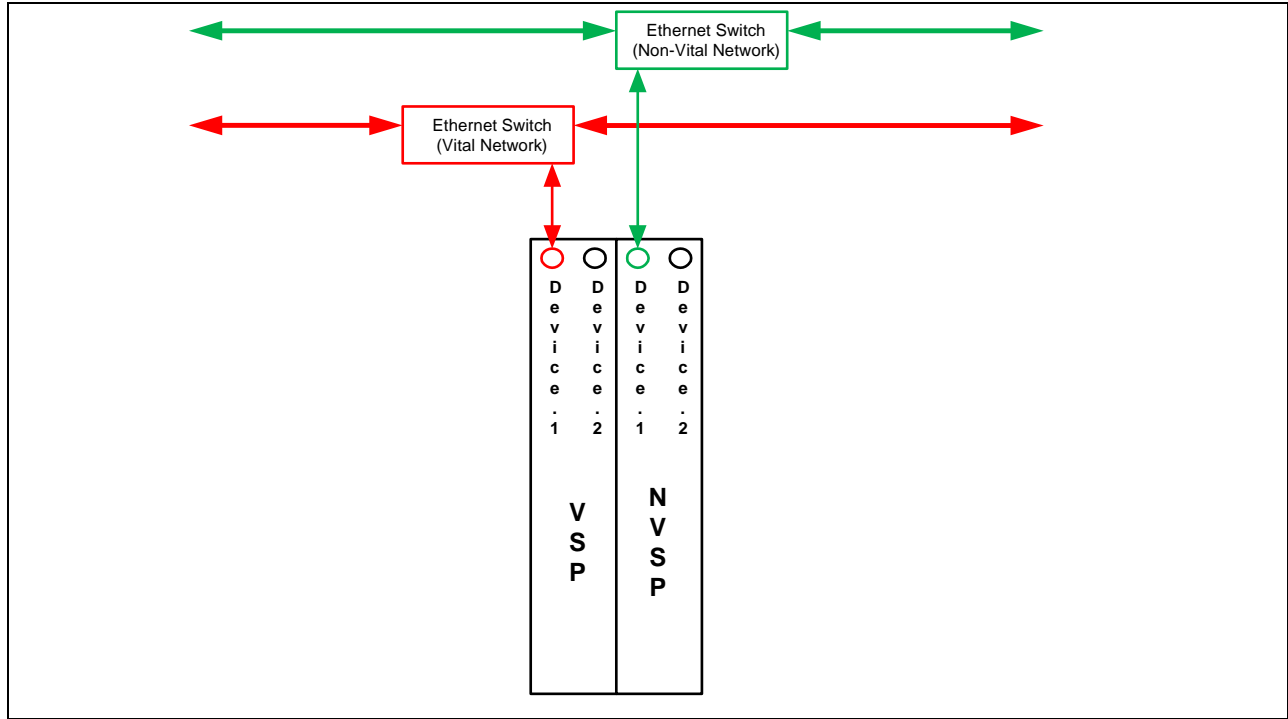

Figure 2–4. Independent Ethernet Backbones Vital Devices Separate From Non-Vital Devices

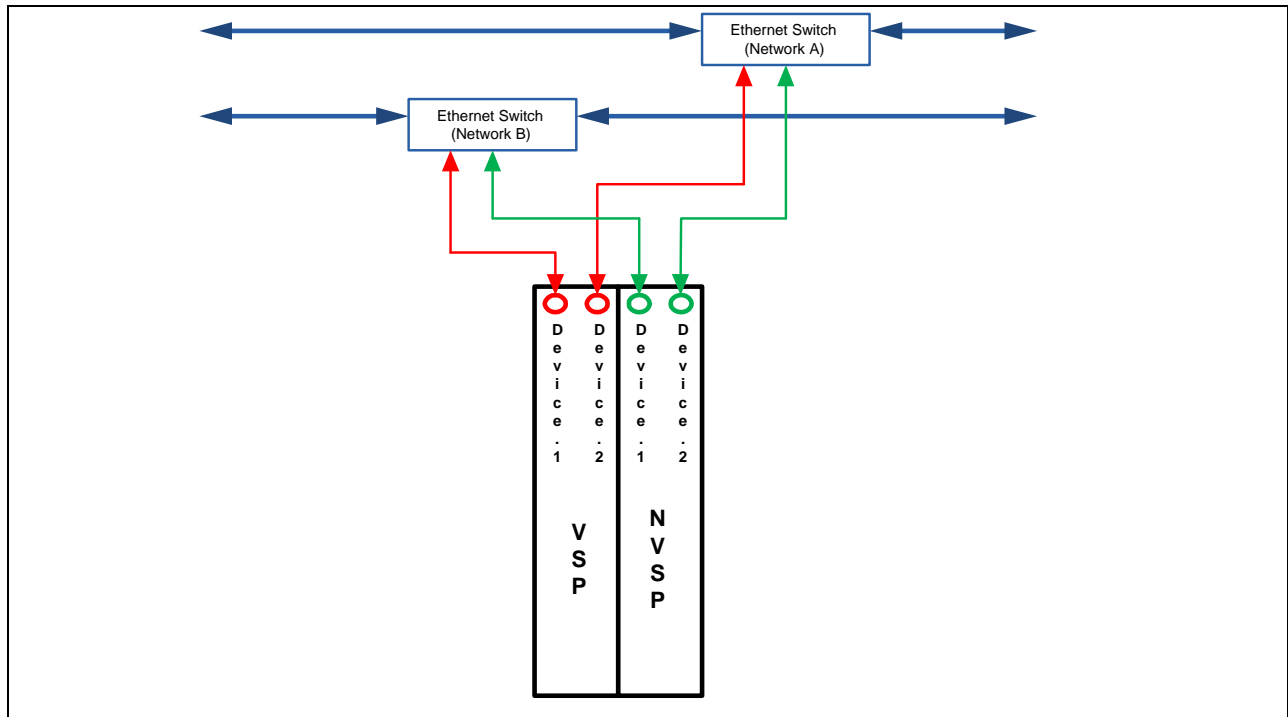

Figure 2–5. Redundant Ethernet Backbones Supporting Vital And Non-Vital Devices

3. SECTION –3 SUBRACK CONFIGURATIONS

3.1. GENERAL

This section describes the Subrack configurations of the iVPI System.

3.2. IVPI SUBRACK DESCRIPTION

The iVPI System is highly modular in design, implemented in a 19 inch rack mounted card cage (Subrack) with a set of plug-in printed circuit boards (boards) that are applied in varying quantities to meet the needs of specific applications. VPI® Systems meet and/or exceed all the applicable 'AREMA (formerly AAR) Communication and Signal Manual of Recommended Practices' requirements.

A single iVPI System is housed in one to four Subracks. Each Subrack has space for twenty-one (21) printed circuit boards. Only two boards in the new iVPI Subrack require a specific slot location. The VSP board is a double wide board assigned to slots 1 and 2. The single slot wide NVSP board can be assigned to any of slots 3 through 8. The iVPI Subrack allows for any other board to be inserted into any slot other than 1 or 2, reducing both set-up and maintenance time. Figure 3–1 is an illustration showing a full 21-slot Subrack. In smaller Systems any unused board slots are covered with blank panels.

Subrack Configurations

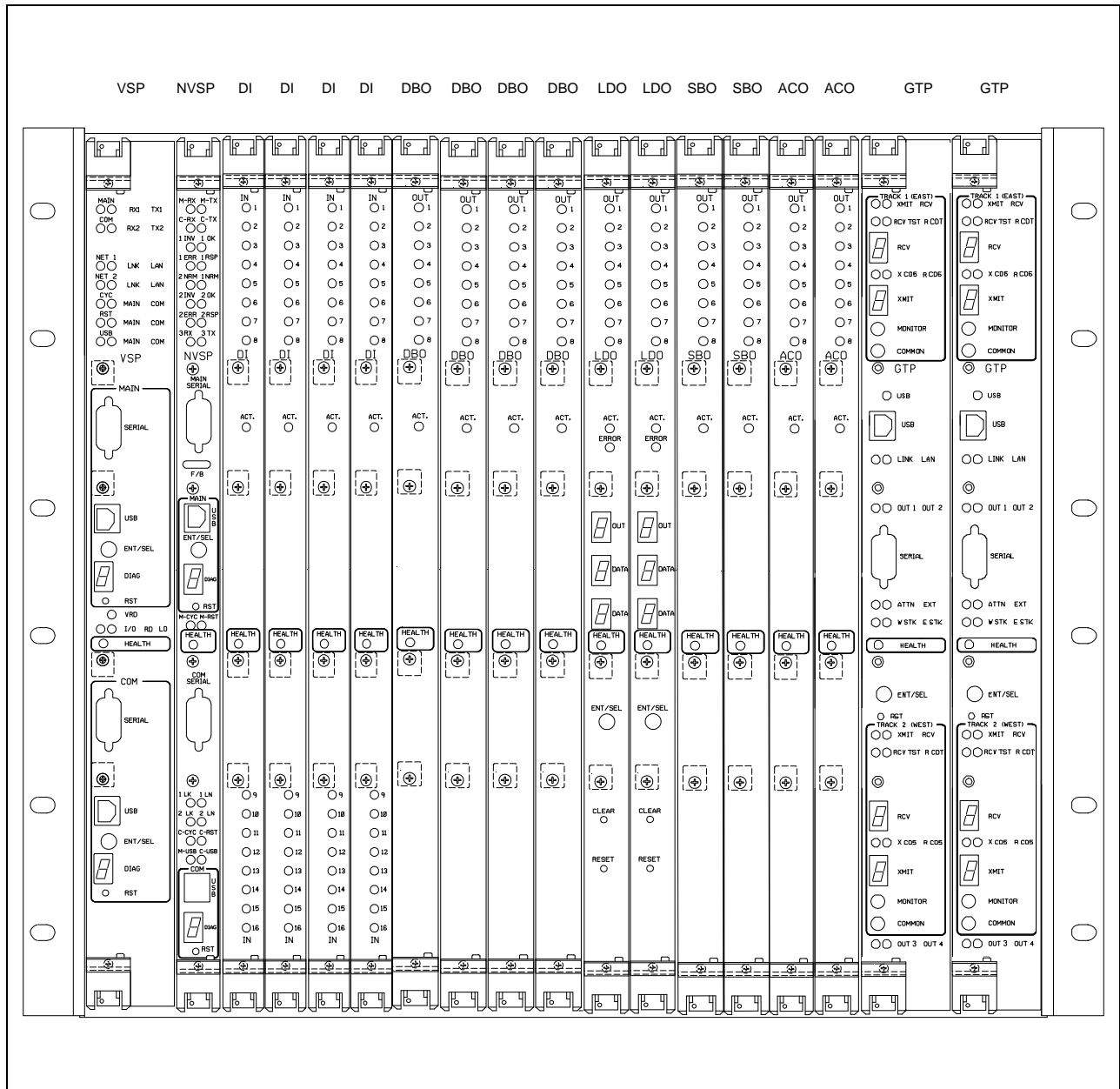

Figure 3–1. 21-Slot iVPI Subrack Filled

When a single iVPI System is expanded into more than one Subrack, the System Bus (incorporated in the Motherboard) is extended to the expander Subracks permitting all boards in the System to operate as if directly interfaced to the processor with no degradation in system performance.

All iVPI printed circuit boards:

- Are mechanically keyed to prevent placement of boards in the Subrack in the wrong card slot,
- Contain LED indicators along the front edge of the board that display the operating status of the board to assist in maintenance, and
- Display I/O functions with individual LED indicators to indicate the status of each I/O point.

Vital iVPI printed circuit boards are electrically keyed, also. All Vital input/output lines have built-in secondary transient protection to prevent disruption of service from external interference.

Table 3–1. Plug Coupled Subrack Part Numbers

Description	Part Number
21-Slot iVPI Subrack with P2 Motherboard, 12 VDC Power Isolation, Power Supply 9-16 VDC, and P1/P3 I/O Interface Boards (source rack 01191-068-00)	31038-823-01
21-Slot iVPI Subrack, Direct Wire, with P2 Motherboard, 12 VDC Power Isolation, Power Supply 9-16 VDC (source rack 01191-069-00, equipped with Z Rail for F connectors used to interface to another iVPI Subrack.)	31038-823-02
21-Slot iVPI Subrack, Direct Wire, with P2 Motherboard, 12 VDC Power Isolation, Power Supply 16-36 VDC	31038-823-03

3.3. BUS EXPANSION (BEX) BOARD

The Bus Expansion (BEX) board is used to enable a single VSP board to control both Vital and non-vital boards in up to three external iVPI expansion Chassis. Each expansion chassis can contain up to 20 boards in addition to the Bus Expansion board. The BEX board resides in slot 1 of each iVPI expansion chassis in place of the VSP board.

The Bus Expansion board serves two purposes; to replicated the P2 backplane I/O Bus, System Bus and I²C Bus of each IVPI expansion chassis, and to provide a buffered continuation of the System Expansion Bus and I²C Bus to a successive IVPI expansion chassis in the System.

Status LED's on the front panel provide a visual indication of onboard and I/O bus activity as well as the presence of chassis power.

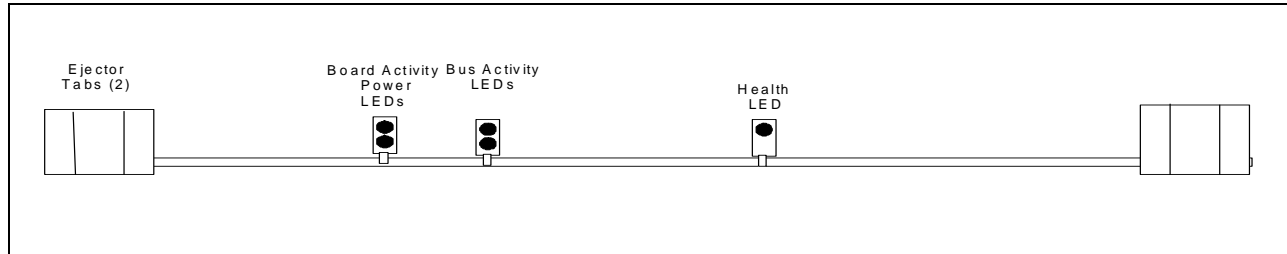

Figure 3–2. IO Bus Expansion Board LEDs

4. SECTION 4 – VITAL SUBSYSTEM

4.1. GENERAL

This section describes the Vital Subsystem of the iVPI System.

4.2. INTRODUCTION

iVPI Systems are explicitly designed for operation in the extremely harsh environments seen in railroad and transit properties. The iVPI product line is designed, validated and verified for operation per the AREMA Communication and Signal Manual, Part 11.5.1 for Class C (Wayside Signal Enclosures) and Class D (Wayside Control Rooms) environments without the need for any special environmental conditioning. In practice, each iVPI System for Vital application is comprised of System boards and the appropriate quantity and type of input and output boards required for the particular location.

iVPI System boards for a typical North American Rail application are:

- Vital System Processor (VSP)

The iVPI Vital input and output boards are the following:

- Direct Input (DI) boards
- Single Break Output (SBO)
- Double Break Output (DBO)
- Lamp Driver Output II (LDO)
- AC Output (ACO)

For typical Freight Rail, Commuter Rail, and Light Rail applications, the following iVPI system boards may also be used:

- Code Rate Generator (CRG)
- Genrakode Track Processor (GTP)

4.3. INDIVIDUAL VITAL BOARD DESCRIPTIONS

4.3.1. Vital System Processor (VSP)

The Vital System Processor (VSP) board is the Vital processing unit of the iVPI System. The VSP board can process thousands of Vital expressions, read up to 320 Vital inputs (20 DI boards), set up to 320 Vital outputs (40 Vital output boards, such as SBO, DBO, LDO, ACO), interface to up to 10 GTP boards (20 GENRAKODE III Track Circuits) and 3 CRG boards (8 coded outputs per board), process up to 300 Vital timers, receive and transmit Vital network data, and receive and transmit non-vital controls and indications, all within iVPI's fixed Vital 1-second cycle time.

Through the use of VPI application tools, an engineer defines the logic, I/O functionalities, and communications to implement the interlocking control functions. Application software is compiled using the tools downloaded directly to the VSP via a USB type connection interface.

4.3.1.1. System Vital Communications

The VSP board includes an integrated two channel Vital network using the VSOE protocol for communicating Vital parameters to other iVPI Systems on a network. The Vital message is constructed using Vital techniques for the Vital parameter states and other Vital data in the message. To survive possible message corruption due to the harsh EMI environment VPI Systems operate within, each Vital message is transmitted two times during the cycle with the receiver requiring only one good reception for proper Vital decoding.

Using patented NISAL™ techniques, the Vital communication messages have Vital security to protect against an iVPI System receiving and decoding messages not intended for it (misrouted messages), or messages that may have been stuck in some communication system memory device and re-transmitted, or to reject messages that have been significantly delayed by the communication system and are too old to be processed vitally. These techniques permit iVPI to successfully utilize non-vital communication networks and equipment to transport Vital messages between iVPI Systems.

4.3.1.2. Logic Processor

All Vital expressions are processed every cycle by the VSP board, and, as such, many inputs from multiple sources may change at the beginning of the cycle and all are processed during that cycle without lengthening the processing cycle. This is a very key performance feature of iVPI Systems that are deployed into large, complex interlocking plants that have a large number of simultaneous train movements. For Vital configuration control, the VSP board directly supports 16 inputs that can be used to set more than 62,000 unique combinations to vitally identify iVPI Site Identification and Revision version.

These inputs are vitally interlocked to the Application Software and to the Executive Software versions at a specific site. This feature fulfills, at the iVPI run-time system level, the requirements of the new (2005) USDOT FRA Regulation on Configuration Management, which is defined in Regulation 49 CFR 236.18 for ensuring the correct software is installed at the intended version level at the intended site and is uniquely identifiable.

4.3.1.3. System Verification

The VSP board includes an integrated Vital Relay Driver function. This function vitally monitors the Vital outputs for permissive Vital output status verification every 50 ms to generate a dynamic output signal that controls power to the Vital outputs. iVPI checks the state of its Vital outputs using a continuous verification data stream on each Vital output during more than 95% of each 50 ms cycle. Using this method, the iVPI System can detect any Vital output failure and vitally remove its power via the VRD relay within a maximum of 140 milliseconds (typically within 100 milliseconds).

4.3.1.4. Vital Timing

The VSP board supports up to 300 software settable Vital timers. The Vital time base is the Vital iVPI main cycle which is vitally accurate to ± 0.002 seconds. This time base is verified by a NISAL™ process, forcing the VRD to drop if the time base ever goes out of tolerance.

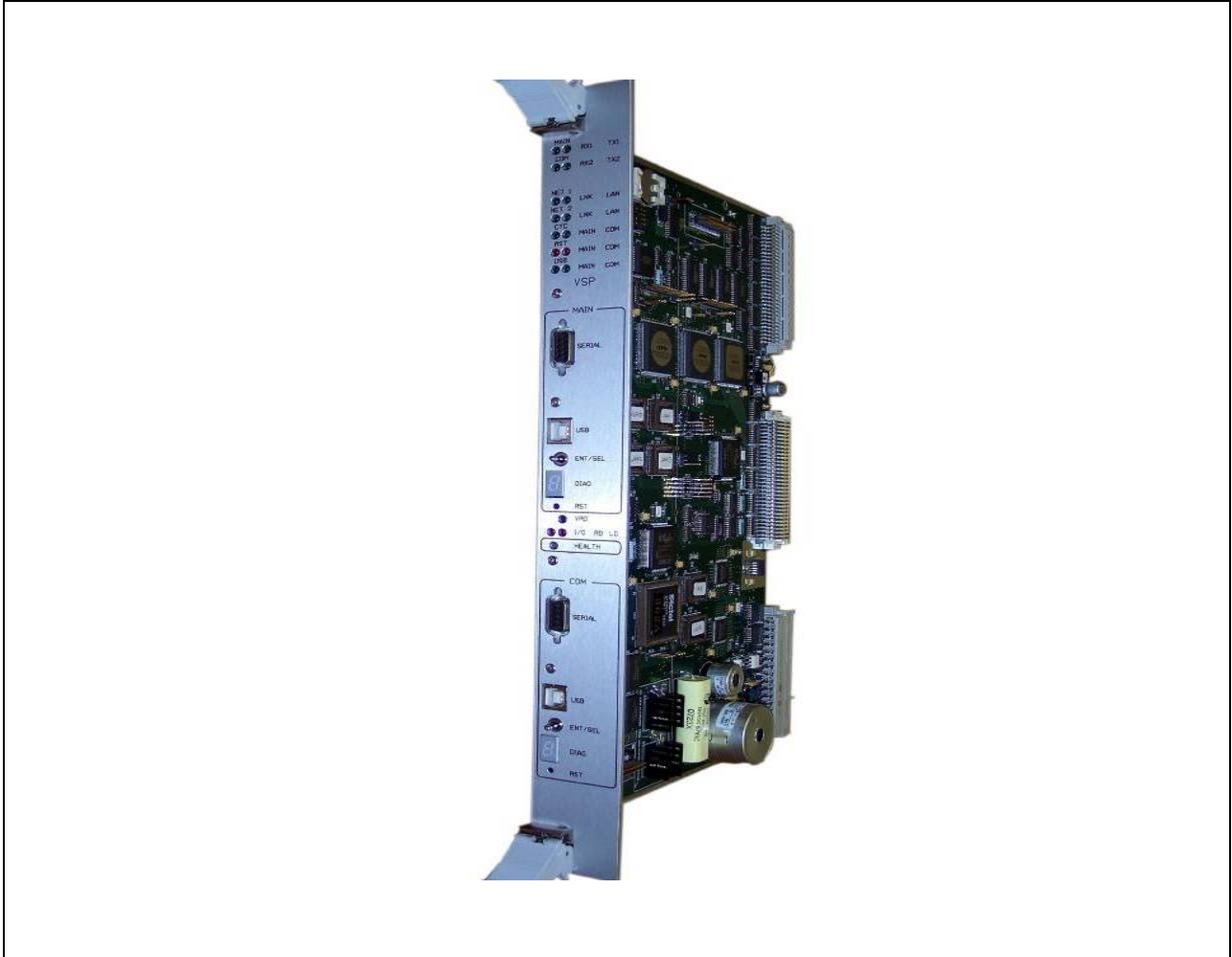

Figure 4–1. VSP Board

4.3.2. Genrakode Track Processor (GTP)

The Genrakode Track Processor (GTP) board is for Commuter, Freight and LRT applications. It plugs into the iVPI Subrack in any slot other than slots 1 and 2, which are reserved for the VSP board. The GTP board is typically used for driving DC Coded Approach Track Circuits. Provided on the board front edge are connections for downloading the Genrakode programs as well as indicators for Codes In/Codes Out, and other maintenance indicators. The GTP communicates over the System Bus portion of the iVPI Motherboard to the VSP, passing Vital and non-vital codes to be transmitted and received.

Through the use of the VPI and Genrakode application tools, an engineer defines the logic and I/O functionalities to implement the train detection function. Application software is compiled by the tools and downloaded directly to the GTP via a USB type communication interface.

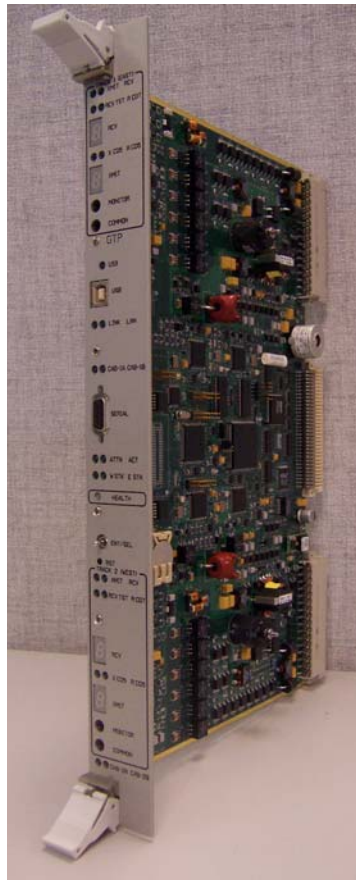

Figure 4–2. Genrakode Track Processor Board

4.3.3. Direct Input

Direct Input (DI) boards are used to vitally input the status of devices such as switch machines, track circuits, line circuits and a multitude of other Vital signal apparatus. The DI boards contain sixteen isolated Vital inputs for DC input current sensing. Each input port has two connections to the field equipment (+IN and –IN), and two inputs may be connected in parallel with opposite polarity to form a bipolar input circuit. Each input circuit is vitally isolated from each other, from ground, and from power using techniques that meet or exceed AREMA isolation requirements (3000VDC). Using a unique Vital time interval sampling technique, Vital inputs are immune from false readings due to induced AC frequencies in the range of 25 to 360 Hz. Appropriate transient protection devices are included in the input circuit on the PC board.

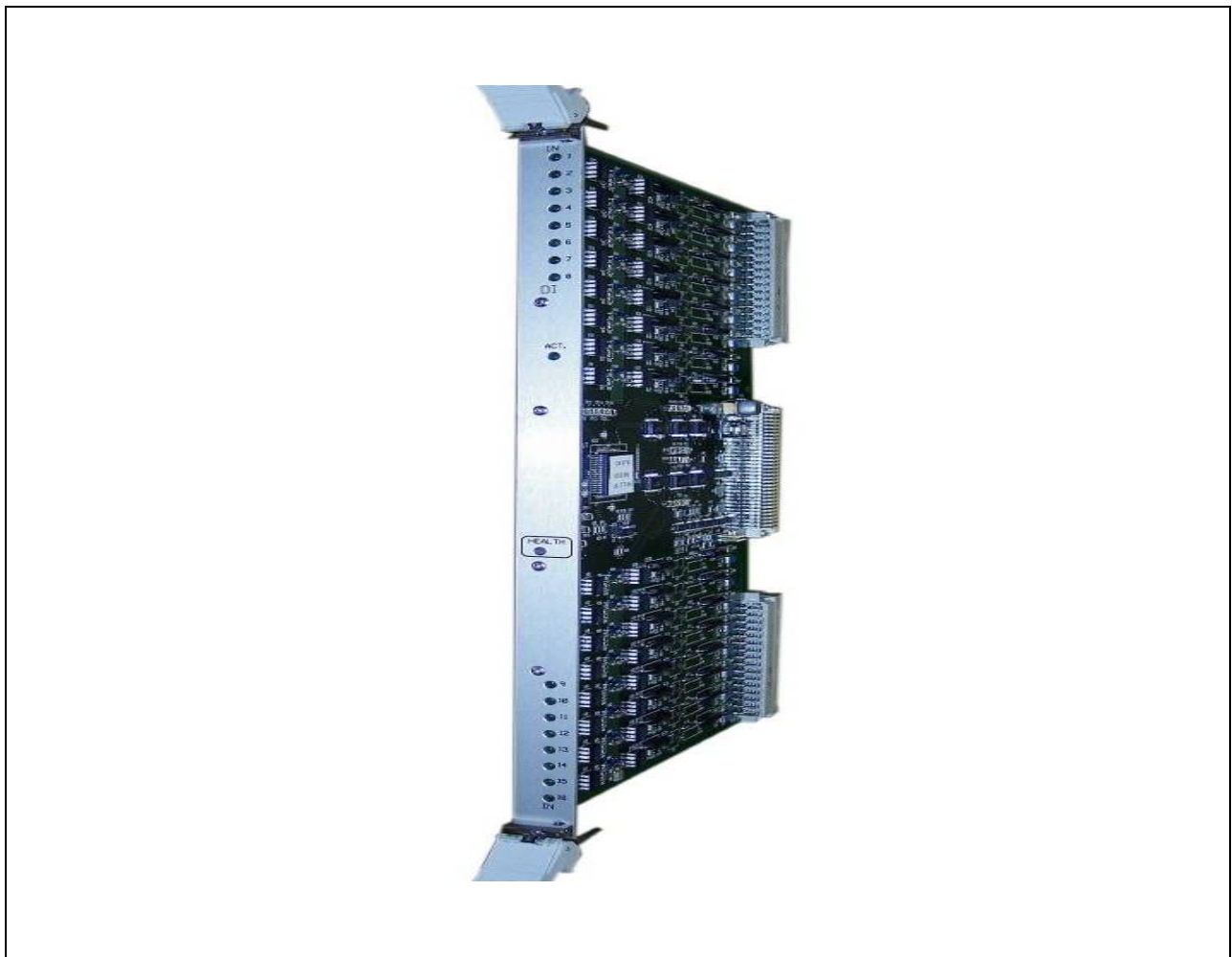

Figure 4–3. Direct Input Board

4.3.4. iVPI Vital Output Board Descriptions

These boards are used to control a wide variety of Vital devices such as switch machines, line circuits, signal lamps and a multitude of other Vital signal apparatus. Vital outputs are available in four distinct types: Single Break Outputs (SBO), Double Break Outputs (DBO), Lamp Drive Outputs (LDO), and AC Outputs (ACO).

These boards have 8 outputs divided into two groups of four. Outputs 1 through 4 are connected to one power supply input while outputs 5 through 8 are connected to a second power supply input.

In Vital applications, these power supply inputs are connected to a source that can be vitally turned off (usually a contact of the VRD relay or one of its repeaters).

4.3.4.1. Single Break Output

Single Break Output (SBO) boards contain eight vitally isolated outputs per board. Each output has one connection to field equipment (+OUT). The negative side of each group of four outputs is connected in common. This group reference is available at the board connector and each group of four outputs may be connected to a different reference. The output port on a SBO board is analogous to a relay circuit with a contact in the feed side of a circuit only. Supply voltage to the output board can be in the range of 9 to 30 VDC with loads up to 0.5 amps.

Appropriate points in the Vital output circuit have RF Bypass capacitors to ground to eliminate RF interference. Appropriate transient protection devices are also included in the output circuits on each PC board.

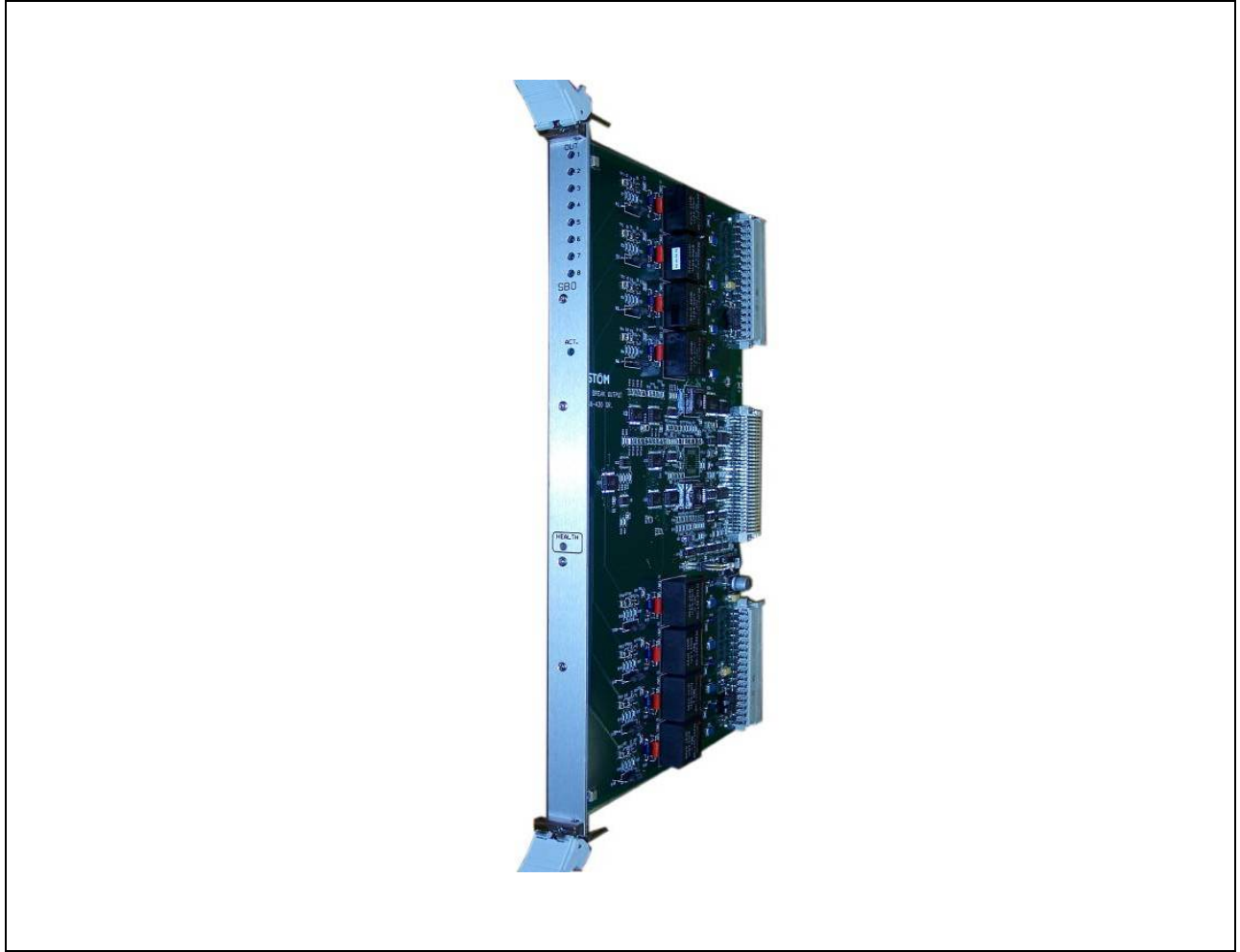

Figure 4–4. Single Break Output Board

4.3.4.2. Double Break Output

Double Break Output (DBO) boards contain eight vitally isolated outputs per board. Each output has two connections to field equipment (+OUT and –OUT) and two outputs may be connected with opposite polarity to form a Bipolar output circuit without requiring a separate external isolator interface for either the Double Break or the Bipolar mode of field connection. The output port on a DBO board is analogous to a relay circuit with contacts in both the feed and return sides of the circuit.

Each output circuit is vitally isolated from each other, from power and from ground. Supply voltage to the board can be in the range of 9 to 15 VDC with loads up to 0.6 amps. Additional board voltages are to be supported as required by specific applications. Being a fully isolated double break output circuit arrangement, this output can tolerate a single point failure to ground or to power without any damage.

Appropriate points in the Vital output circuit have RF Bypass capacitors to ground to eliminate RF interference. Appropriate transient protection devices are also included in the output circuits on each PC board.

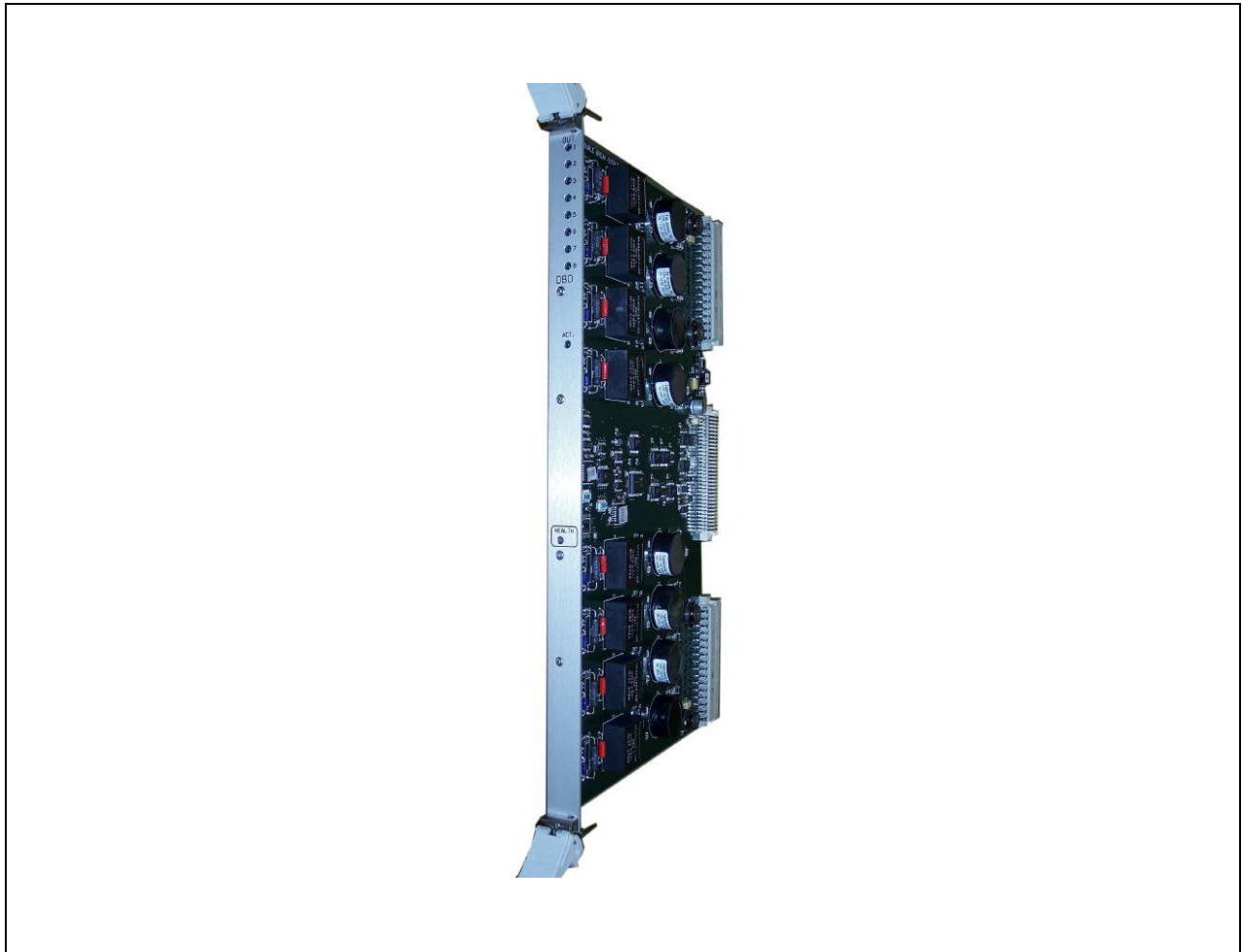

Figure 4–5. Double Break Output Board

4.3.4.3. Lamp Drive Output

Lamp Drive Output (LDO) boards contain eight Vital outputs per board designed to directly drive incandescent signal lamps or to directly drive signal lamp LED assemblies. Each output has a Sourcing Drive (positive side switch) capable of providing a maximum output current of 3.3 amps per port. The supply voltage to the board can be adjusted externally to account for line losses to the bulb/LED signal assembly in order to get the desired voltage at the bulb/LED Signal Assembly (provided the 3.3 amps per port is not exceeded). Each port has over-current protection and over-current detection with an appropriate diagnostic.

The LDO board includes hot and cold filament check for incandescent bulbs and for approved LED Signal Assemblies as well as an adjustable low level current detection threshold range for LED signal assemblies. Each group of four output ports shares a common reference signal. The positive side of each output circuit is vitally isolated from each other, from power and as a group of four outputs from ground.

Appropriate points in the Vital output circuit have RF Bypass capacitors to ground to eliminate RF interference. Appropriate transient protection devices are included in the output circuits on each PC board.

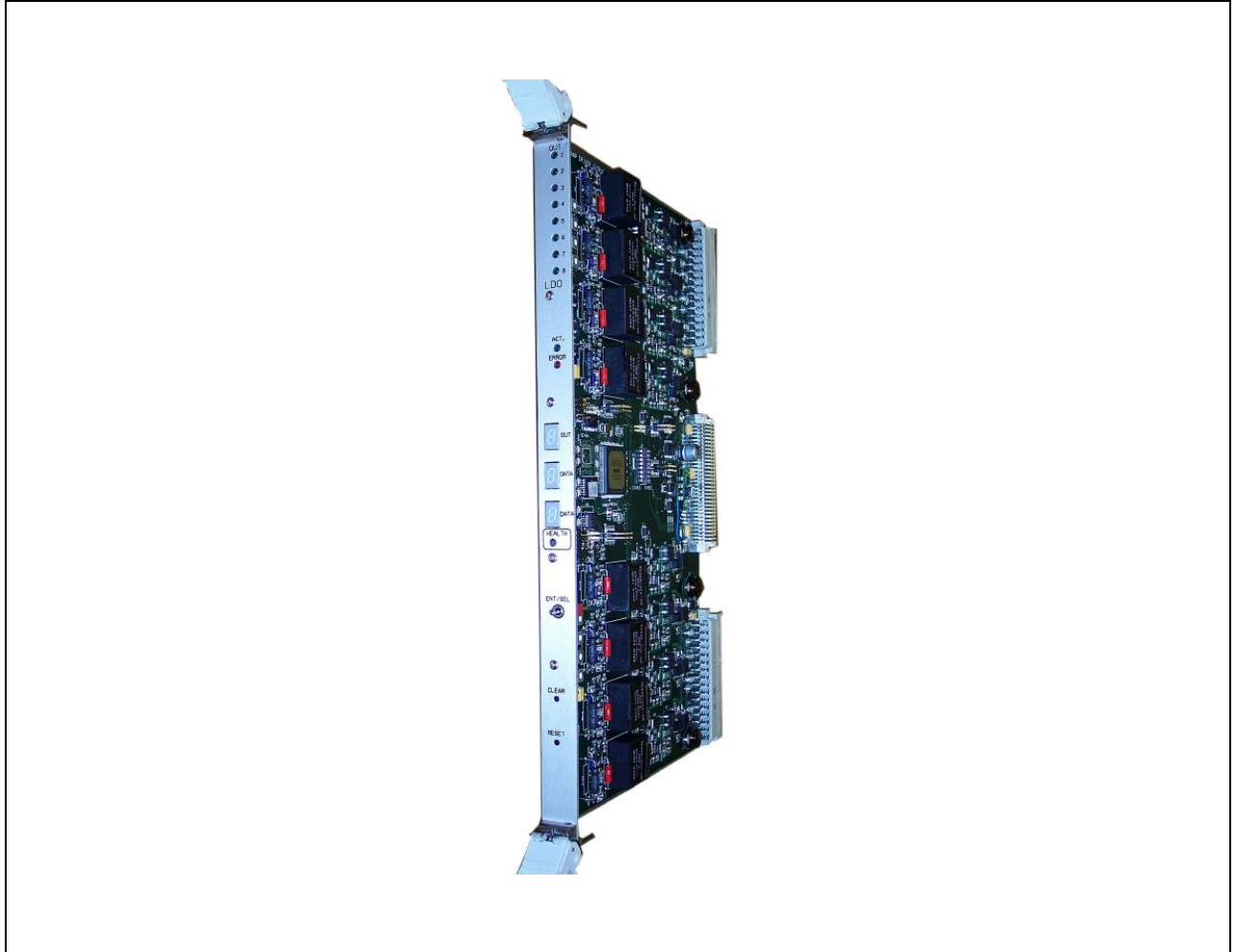

Figure 4–6. Lamp Driver Output Board

4.3.4.4. AC Output

The Vital AC Output (ACO) Board is used for lighting signal lamps or for operating other AC loads requiring less than 0.8 ampere.

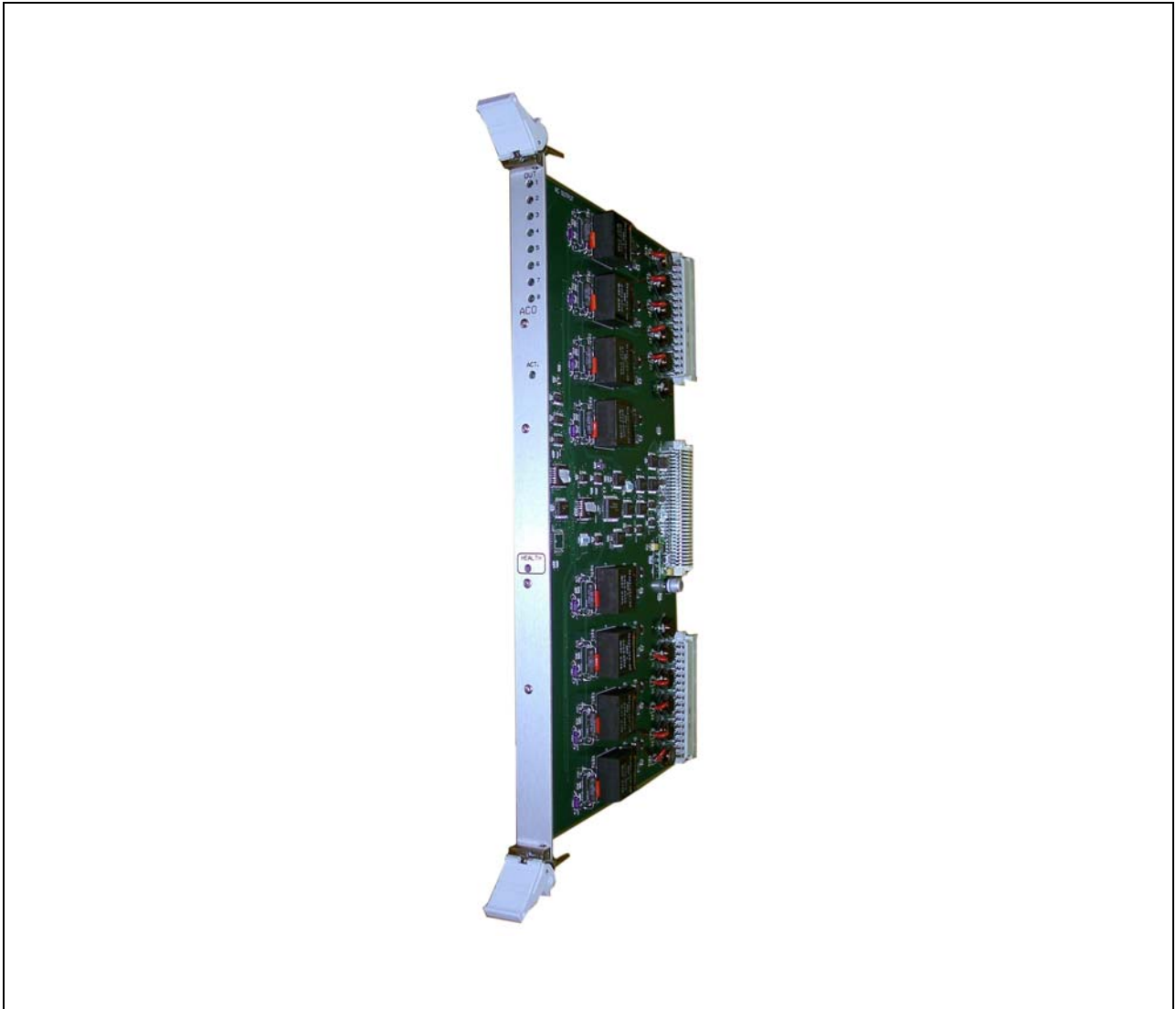

Figure 4–7. AC Output Board

4.3.4.5. Code Rate Generator

The Code Rate Generator (CRG) board contains eight vitally isolated outputs per board. The CRG board has its own Vital processor engine for generating and proving the pulsed outputs typically used to generate cab signal outputs. Each output has two connections to field equipment (+OUT and –OUT). The output port on a CRG board is analogous to a relay circuit with contacts in both the feed and return sides of the circuit.

The CRG communicates over the system Bus portion of the iVPI Motherboard to the VSP passing Vital code to be transmitted.

Each output circuit is vitally isolated from each other, from power and from ground. Appropriate points in the Vital output circuit have RF Bypass capacitors to ground to eliminate RF interference.

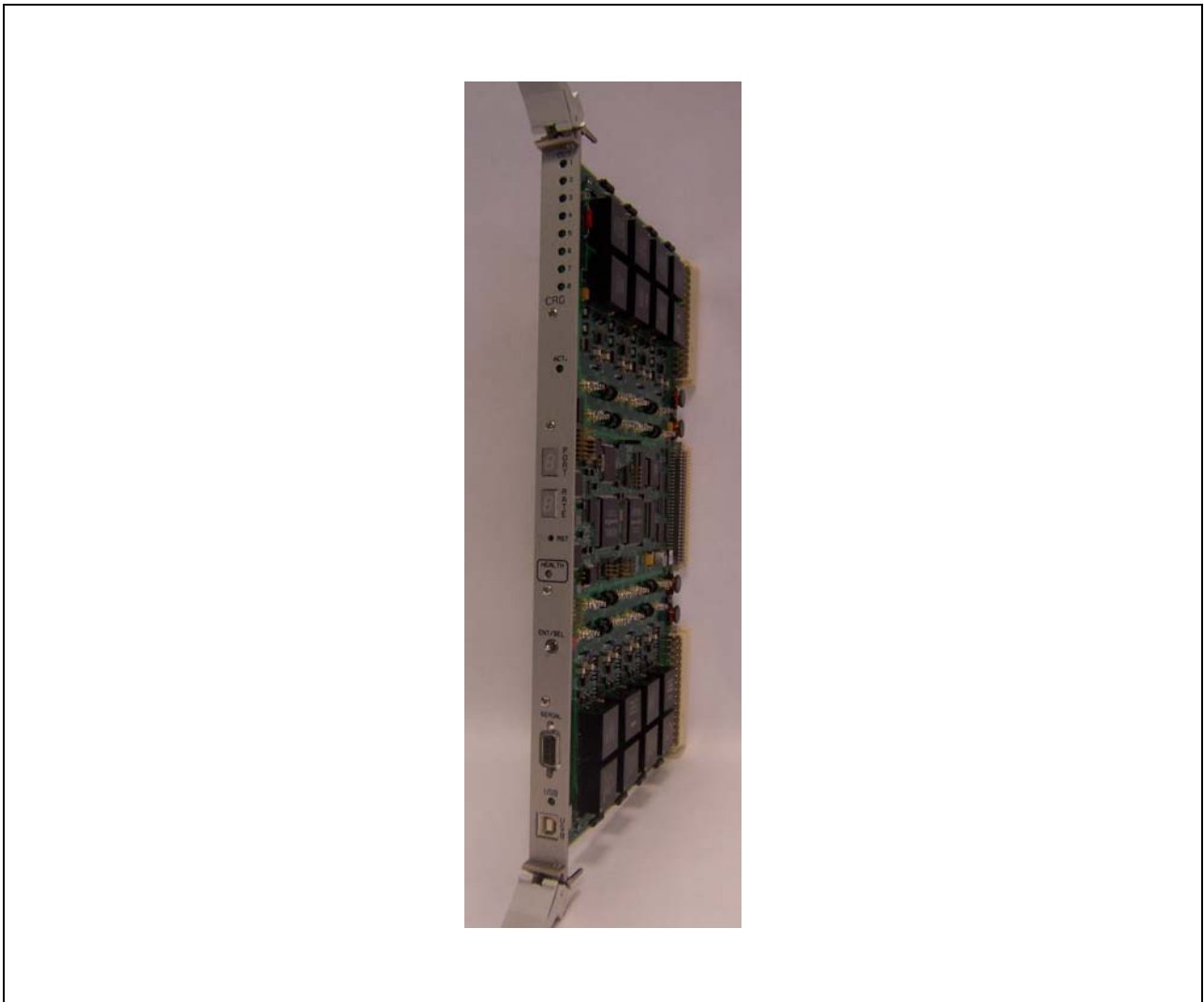

Figure 4–8. Code Rate Generator Board

THIS PAGE INTENTIONALLY LEFT BLANK.

5. SECTION 5 – NON-VITAL SUBSYSTEM

5.1. GENERAL

This section describes the Non-Vital Subsystem of the iVPI System.

5.2. INTRODUCTION

For non-vital applications, the iVPI System consists of one or more Non-Vital System Processor (NVSP) board(s), and the quantity of Non-Vital Input (NVI) and Non-Vital Output (NVO) boards required for a particular application. The non-vital iVPI System is contained either in a Subrack identical to the iVPI Vital System or within a section of a Vital iVPI SUBRACK. Communications between the non-vital System and the Vital System is via the Motherboard (within the System when non-vital and Vital Subsystems share the same System or an expansion cable when the two Subsystems are in different Subracks).

An iVPI System can include up to four NVSP boards on the System Bus, thus allowing many arrangements for load sharing, if required. The NVSP board can also operate in a completely standalone mode independent of being connected via the System Bus to a Vital processor. In either the standalone or in the connected arrangement, a NVSP board can interface with up to 20 non-vital I/O boards (housed in the same Subrack as the NVSP) of 32 I/O points each for a total of 640 non-vital I/O points per NVSP board.

The iVPI non-vital System board and the non-vital input/output boards are:

- NVSP – Non-Vital System Processor
- NVI – Non-Vital Input
- NVO – Non-Vital Output

Through the use of the VPI application tools, an engineer defines the logic, I/O functionalities, and communications to implement interlocking non-vital control functions. Application software is compiled by the tools and downloaded directly to the NVSP via a use type communication interface

5.3. INDIVIDUAL IVPI NON-VITAL BOARD DESCRIPTIONS

5.3.1. Non-Vital System Processor

The Non-Vital System Processor (NVSP) board has two Ethernet communication channels and four serial ports (three ports which are programmable, one port is always the MAC – Maintenance ACcess) available with each serial port being capable of operating up to 57.6KBPS. The NVSP board is designed such that it can also be interfaced directly to standard communication equipment such as Fiber Optic Modems, Multiplexers, and Network Adapters.

The NVSP board can be application programmed with non-vital logic to perform Human Machine Interfaces (HMI), entrance-exit logic and a multitude of other non-vital functions. The NVSP board can be used to interface with communications based Local Control Panel and/or HMI computers; or by using the NVI and NVO boards it can directly interface to discrete wired Local Control Panels and non-vital support functions.

The NVSP board also contains a battery backed-up memory section and clock/calendar to support the onboard DATALOGGER™ software used for logging both Vital and non-vital variables. Three of the communication ports in addition to the two Ethernet ports can be utilized for external non-vital communications. Each port may be configured with the same or with a different communication protocol. The choice of protocols is assigned and configured in the Computer Aided Application tools by the signal engineer.

A library of almost forty communication protocols common to the railroad and transit industry is included in the Computer Aided Application package. Typical protocols included are industry standards such as GENISYS, Data Train, MODBUS, and MODBUS/TCP among others.

5.3.2. Non-Vital Input

Non-Vital Input (NVI) boards provide 32 isolated inputs, which are read every 25 ms by the NVSP board. Optical isolators separate the power supplies of the 5VDC board logic from the field circuitry. Each of four groups of eight inputs shares a common signal return.

Transient protection devices are included in the input circuits.

5.3.3. Non-Vital Output

Non-Vital Output (NVO) boards provide 32 isolated outputs, which are controlled by the NVSP board. Optical isolators separate the power supplies of the 5VDC board logic from the field circuitry.

Transient protection devices are included in the output circuits.

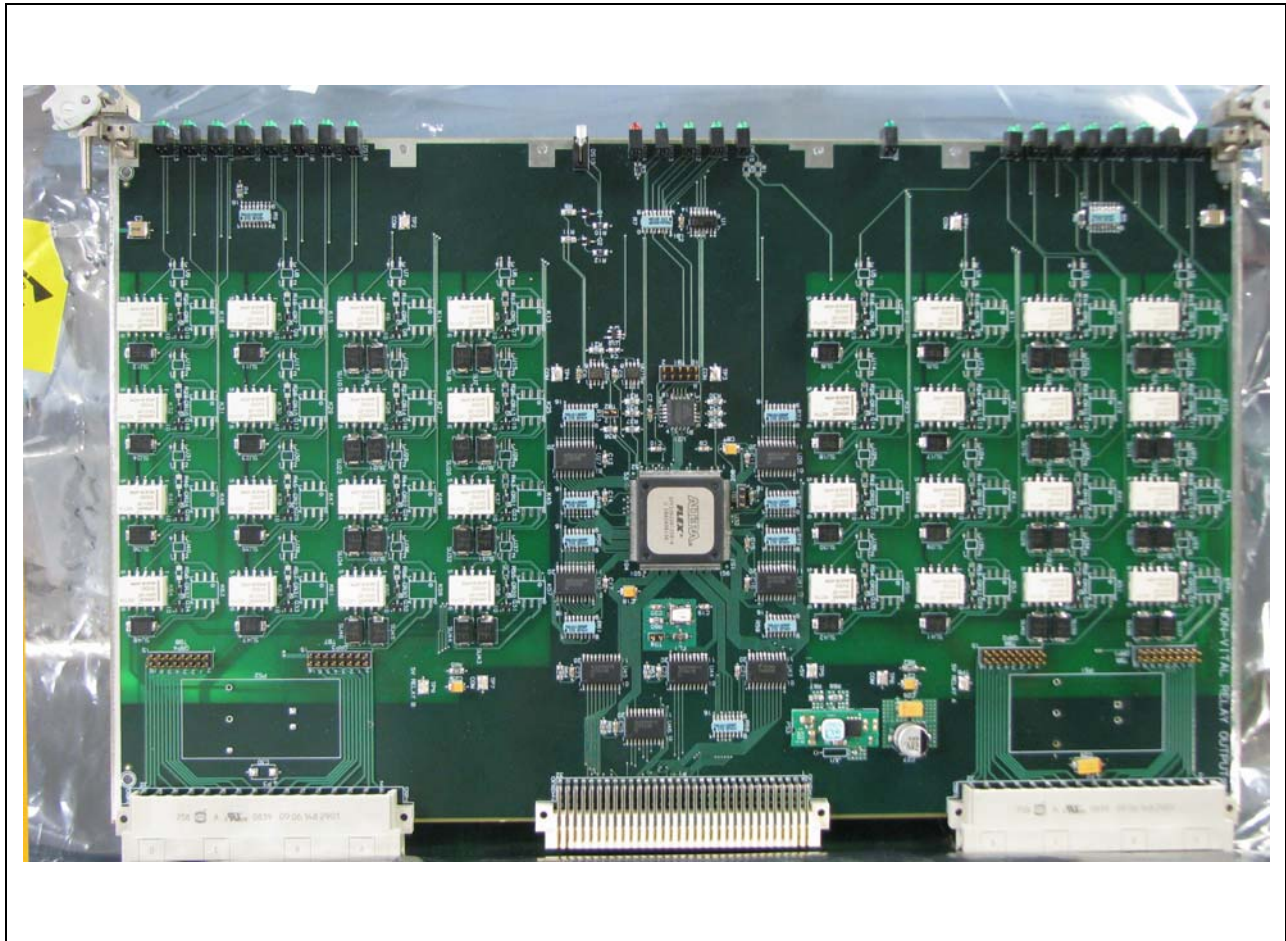

Figure 5–2. NVO Board

6. SECTION 6 – DESIGN, TEST AND VALIDATION TOOLS

6.1. GENERAL

This section describes the design, test and validation tools available for the iVPI System.

6.2. INTRODUCTION

The Vital System performs all Vital logic associated with interlocking control (switch control, locking, and signal control). At the user's option, this logic can be written in the form of Boolean equations or drawn as relay circuits in AREMA Drop-Line format, AREMA Straight Line format or as commercial PLC format that emulate traditional relay logic. No special programming language is used in the application thus allowing the source file(s) to be easily understood by a signal engineer.

After the Boolean equations or relay diagrams have been created by the Signal Engineer, the Computer Aided Application (CAA) software package is used to compile the equations into machine readable code for installation and verification on the application FLASH EPROM to be installed on the appropriate System's VSP board.

The non-vital System performs similar functions on all non-vital logic associated with interlocking control (switch position requests, signal clear requests, Local Control interface, remote control communications, local data logging). Through the use of ALsDload, the NVSP applications can be compiled without removing the FLASH EPROM.

Table 6–1. Design Test and Validation Tool Part Numbers

Description	Part Number
CAAPE CD-ROM	31754-008-GR.
Maintenance Management System (MMS) CD-ROM	51795-063
Relay Equivalent Drawing Package (REDP)	

6.3. APPLICATION DEVELOPMENT TOOL

The Computer-Aided Application Programming Environment (CAAPE) is a comprehensive set of development tools for creating iVPI Vital and non-vital applications. These tools are integrated together within a Windows based development environment for easy access.

The CAAPE package is intended for use by Alstom signal engineers, by railroad and transit signal engineers, and by third party signal engineering consultants. The iVPI CAAPE toolset is built on the same stable foundation that has become an industry-accepted favorite, and is backward compatible to all previous versions.

The top-level CAAPE program provides access to available tools and manages application data through the use of projects. A project is a collection of files describing one or more applications. Some of these files, such as report and prom files are meant to be directly accessible by the user; others are for internal use and are readable only by CAAPE. Typically, a CAAPE project describes all the applications in a particular iVPI System.

All the files for a given project are contained in a single directory. A single main project file acts as a directory to the rest of the files in the project and specifies the CAAPE options selected by the user for the project. When the CAAPE opens a project it reads the main file to determine the full list of files and options in the project. Tools to assist in software configuration control are included within the CAAPE package.

The lower-level tools such as compilers and application data verifiers, which are tied to a particular version of iVPI System software, comprise a CAA package. The CAAPE can provide access to the tools in multiple CAA packages (Windows versions only). The user can select which set of compiler and data verifier tools to use for a particular application by selecting a specific compiler version based on which version of Vital system software is used. This allows support of older versions of the VPI product line as well as newer versions in the same development environment.

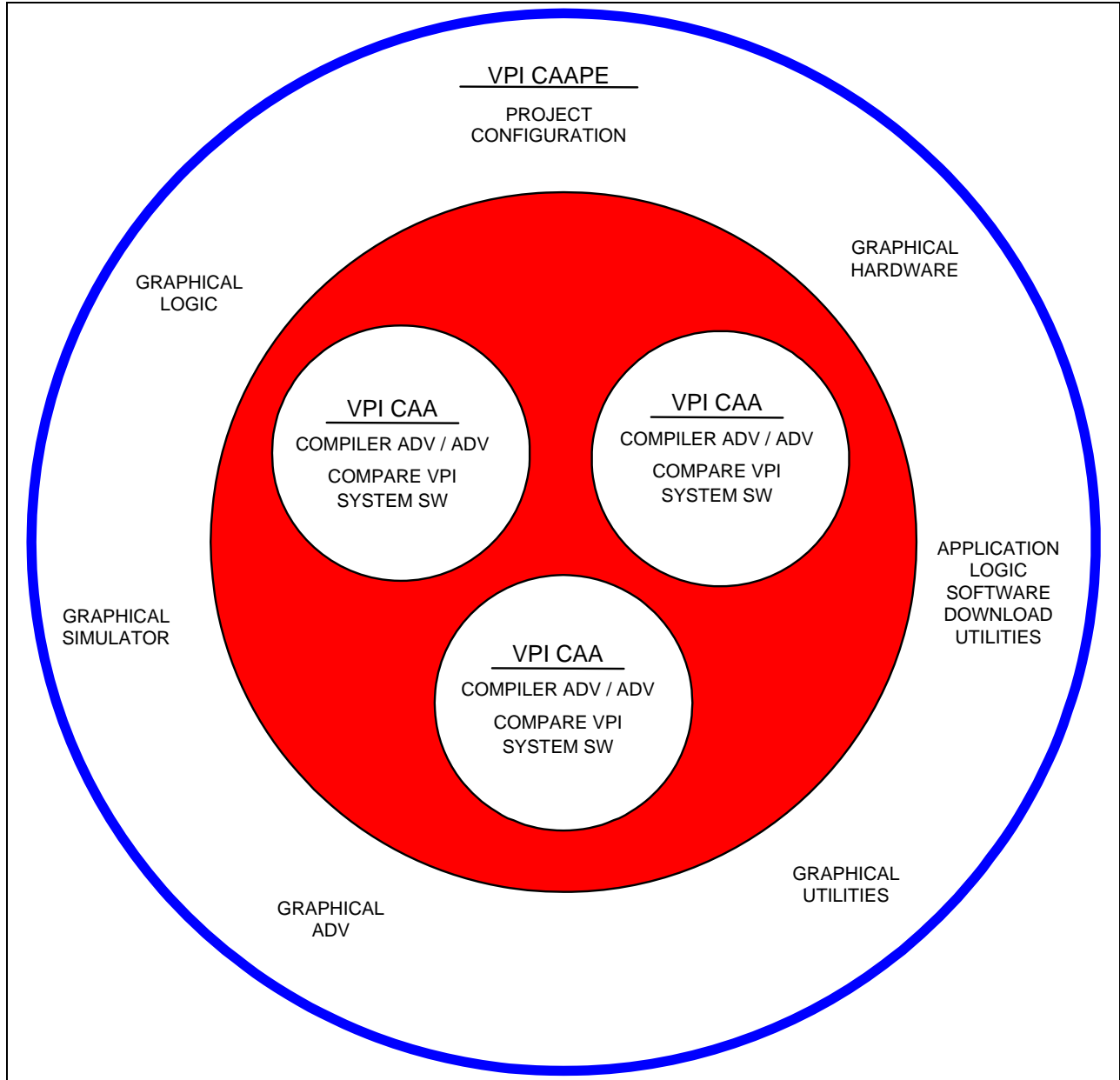

Figure 6–1. iVPI / VPI CAAPE/CAA Typical Arrangement

CAAPE, designed for Windows 95, Windows 98, Windows NT™, Windows 2000, Windows/XP, Windows Vista, and later operating systems, includes:

- Compilers for iVPI Vital and non-vital applications
- Application Data Verifier (ADV) for iVPI
- ADV Comparison for iVPI for identifying differences between two VPI Application Programs
- Graphical Simulators for both iVPI Vital and non-vital logic
- ALsDload – a FLASH program with a software configuration checker
- Utilities such as:
 - PROM file generation
 - I/O Label generation for printer/plotters
 - Consolidation report for iVPI ADV
 - Relay equivalent circuits for final documentation
 - System Hardware and Software Configuration Reports for Configuration Management
 - Utilities to convert to/from Text format (Boolean Equations) and Graphic Format (Relay/Ladder Logic Graphics)

The CAAPE package uses a project-based architecture that allows the user to create projects containing any number of iVPI applications. Computer programming experience is not required; applications can be built using either graphical or textual methods. The graphical methods include form entry, pull-down lists, extensive prompts, online documentation, and a HELP facility to guide the designer through the process. An extensive, stand-alone tutorial is also provided for easy training and reference.

The CAAPE package can be used for both Vital and non-vital applications, and includes a database function to store and organize all relevant data. An extensive documentation section makes it easy to track applications through various stages of development and provides enhanced revision control.

Online, context-sensitive assistance is available through the HELP facility in the form of a SEARCH window. Also accessible from the HELP menu, the comprehensive tutorial provides an easy reference guide and training tool for the CAAPE package. The program allows the viewer to follow the creation of a typical new application from the beginning to end, and also contains an index for handy access to the main control topics and a full set of user manuals.

6.3.1. CAAPE Operation

The CAAPE design tool shows project contents, graphical logic editing and compile results in a message window to illustrate the integrated nature of CAAPE. CAAPE provides:

- Integrated project-oriented environment for developing, compiling, and verifying applications and for managing input, output and report files.
- Graphical entry of application data, including graphical logic with AREMA Straight Line or Drop Line symbols, or PLC Ladder Logic symbols. The user can switch from any symbol set to another at any time.
- Traditional text-based (Boolean equations) application data entry is supported as well.
- Compiler configuration reports include date/time of input and output files, system software versions, calculated checksums and CRCs.

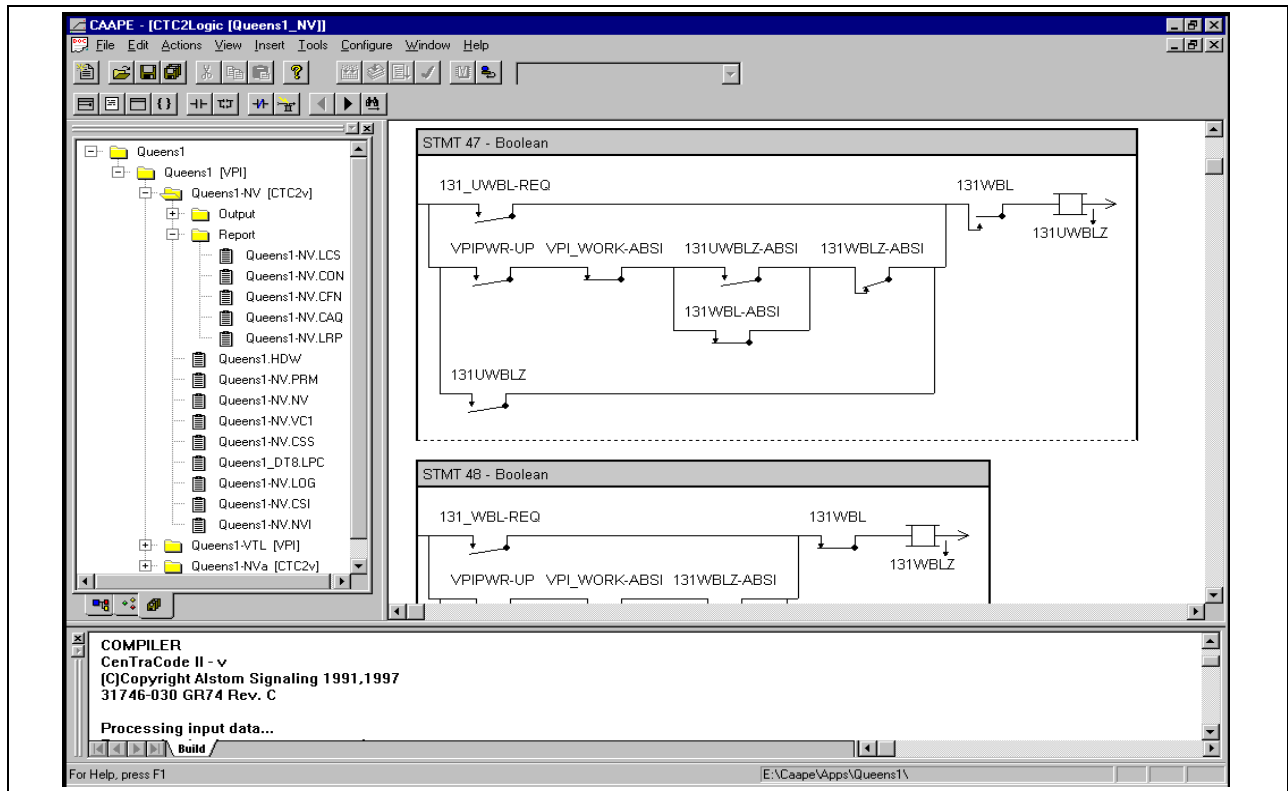

Figure 6–2. CAAPE Relay Application Logic Display (Depicting AREMA Drop Line Symbols)

6.3.2. Application Data Verification (ADV) and ADV Comparison

The ADV is a CAAPE utility that is used to verify a compiled design, as it is resident in iVPI System Memory. This feature has been an integral component of the VPI tool set since the first VPI entered revenue service in 1986 and has continued to evolve through all feature enhancements to the VPI and iVPI product line.

The ADV Comparison program highlights the differences between two versions of an iVPI Vital application. This feature was added in the early 1990's to support large multi phased distributed VPI installations and is a core component of the 'incremental' ('reduced') retest philosophy.

In general, the ADV:

- Reconstructs Application Design From Flash EPROM
- Generates Reports For Circuit Check
- Used to Reconstruct Entire Application From the Application .Hex File
- Creates the Equivalent of an Electronic Book Of Plans
- Provides for a Difference Utility that Highlights Changes
- Provides Security Far Beyond Simple Checksums
- Validates Configuration Management

Specifically:

- Application Data Verifier (ADV) helps verify that application prom data matches intended user input. New Consolidation Reports simplify analysis of ADV data.
- "Graphical ADV" helps verify that graphically entered logic matches prom data. ADV Compare program compares ADV reports to highlight differences between applications in their Vital logic, symbols, messages and I/O.
- ADV Compare program compares ADV reports to highlight differences between applications in their Vital logic, symbols, messages and I/O

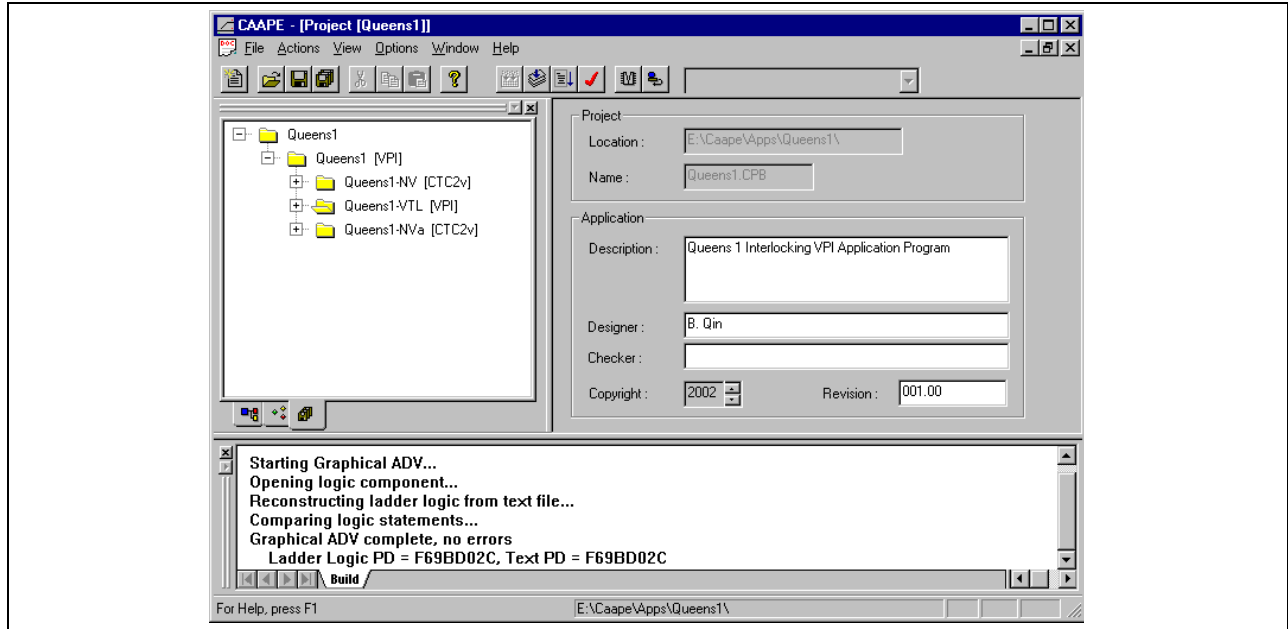

Figure 6–3. Graphical ADV – Compares Logic Input to Output Files With CRCs

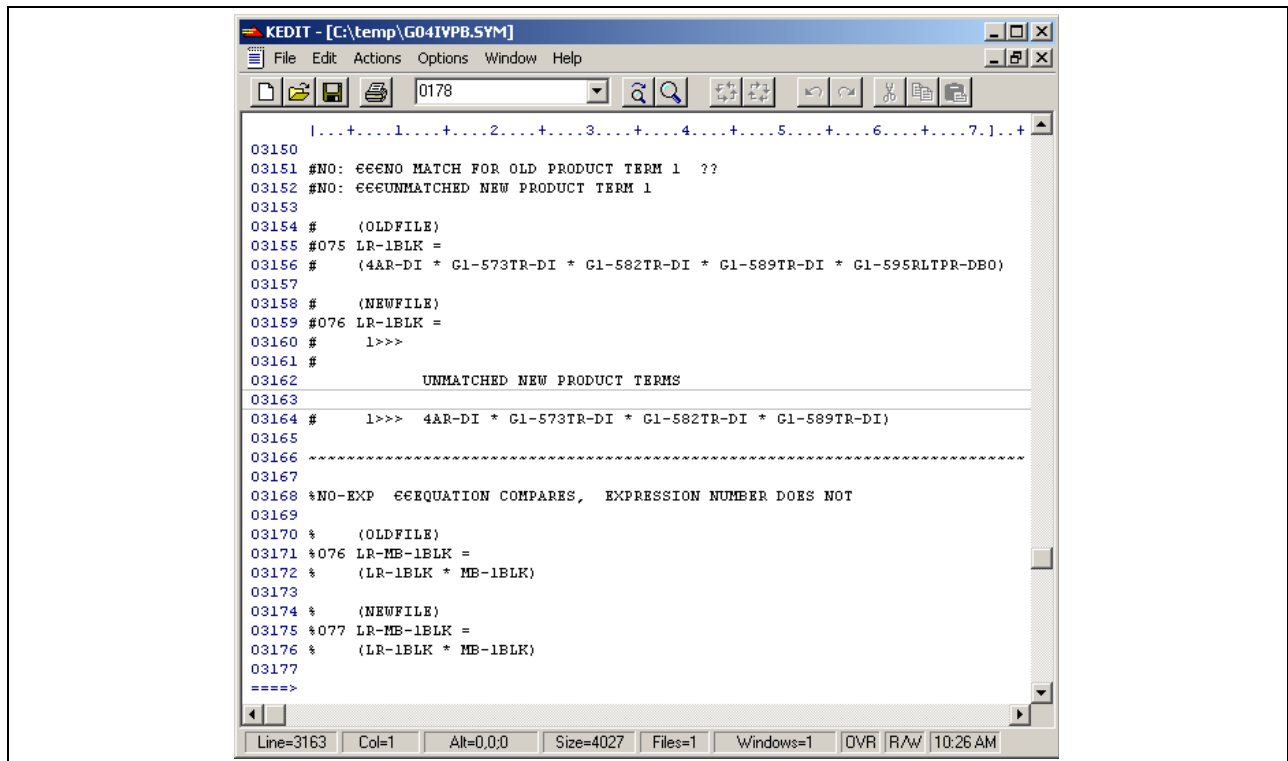

Figure 6–4. ADV Comparison Report Depicting Expression Changes on a Boolean Expression

6.3.3. Graphical Simulator – Integrated and Provided With the CAAPE Package

The Graphical Simulator shows project contents, watch window and track plan display (refer to Figures 6–5 and 6–6). It is used to:

- Simulate multiple Vital and non-vital applications simultaneously. Large distributed iVPI System arrangements can be simulated at one time with both discrete I/O and communication links simulated between systems as well as to field apparatus and control offices.
- Provide timing data to analyze iVPI System response time to the various operations.
- Inject many types of failures (broken filaments, blocked switch points, failed communication links).
- Easily manipulate and observe system behavior.
- Model many types of field apparatus. User can add additional simulated apparatus.
- Utilize a user defined track plan display to simulate operation of field devices.
- View status of application logic in graphical format, set breakpoints to stop simulation at specific points in the logic.
- Monitor and record the states of selected variables.
- Provide a project-oriented interface similar to CAAPE.
- Provide a Watch Window.
- Test Scripts and User defined Command Sequences.
- Support multiple physical and multiple virtual screens for large systems and large interlocking plant simulations.
- Function as an engineering aid to debug new designs, to investigate reported field problems, and as a training tool for new operators and engineers.

6.3.4. AlsDload

AlsDload is a tool for programming application and system software on VPI, WIU, iVPI, and PGK boards.

AlsDload provides the following capabilities:

- Download of application and/or system software from files on the PC to the programmable memory on the board.
- Upload of application and/or system software from the programmable memory on the board to files on the PC.
- Verification that board configuration data is identical to that in selected files.
- Access to board diagnostics.
- Basic VT100 terminal emulation.

6.3.5. CAAPE System Benefits

The exclusive and incomparable benefits that are offered as a result of implementing iVPI with the CAA tools package include:

- The CAAPE is a Computer Aided Application Programming Environment. The Package is set up to operate on a Windows Operating System and is compatible with Windows 9X, NT, 2000, XP, Vista, and later operating systems. The system allows for configuring, compiling and simulating VPI Systems.
- Overall test time is decreased, and application hardware can be tested without hardware. The "Application Data Verifier" (ADV) validates changes that are made to the Vital application software ensuring that only the desired changes are incorporated. This system generates configuration comparison reports automatically and compares then to the original program.
- The Vital processor supports future interfaces and in doing so has the aggregate capacity of processing up to 2,000-4,000 Boolean logic equations per second without any change in cycle time dependent upon the number of changed inputs. Programming can be either Boolean equations or relay equivalent circuits drawn in AREMA Drop Line, AREMA Straight Line or commercial PLC Ladder Logic format. The user can switch from any format to any other format as desired. Any format can be used to generate hard copy drawings of the equivalent circuits as a final system output for documentation.
- The CAAPE package for the iVPI Control System contains a tool called the Graphical Simulator that allows the user to generate control and indication panels, the field apparatus, and simulators to exercise the Vital and non-vital logic on a standard PC screen(s). The logic equations and variables can be viewed graphically with the corresponding states during the simulation run-time. Multiple iVPI Systems can be simulated simultaneously, and the states of selected equations can be monitored and recorded.

6.3.6. CAAPE System Requirements

Table 6–2. CAAPE System Requirements

Operating System (OS)	Windows® 95/98	Windows NT® 4.0/ Windows® 2000/XP
RAM	16 Meg	32 Meg
CPU	486/25 or compatible	586/Pentium or compatible
Hard Disk	200 Meg available	500 Meg available
Input Device	Keyboard and Mouse	Keyboard and Mouse
Display	VGA (640 x 480)	VGA (640 x 480)
Other	CD-ROM	CD-ROM

6.4. MAINTENANCE MANAGEMENT SYSTEM (MMS)

6.4.1. Introduction

The iVPI Maintenance Management System (MMS) is an Alstom diagnostic tool that can remotely monitor each iVPI Vital and Non-vital networked System.

The Maintenance Management System (MMS) runs on a PC under Windows NT 4 (SP 6), NT/2000, XP, Vista, or later operating systems. An MMS Editor is supplied to allow easy modification to any MMS Project. MMS is built of many Commercial Off The Shelf (COTS) components, which the end-user has access to in order to modify and customize the system to his needs.

MMS functionality includes:

- Fault Detection
- Logging
- Graphical User Interface
- Graphical System Diagnostics at the Board Level
- Verify the Installed Hardware and Software Components
- Quickly Select and Diagnose any System
- Troubleshooting using Application Explorer
- Watch Application Parameters and Logic while the Systems are Running
- Configuration Management
- Task Scheduler

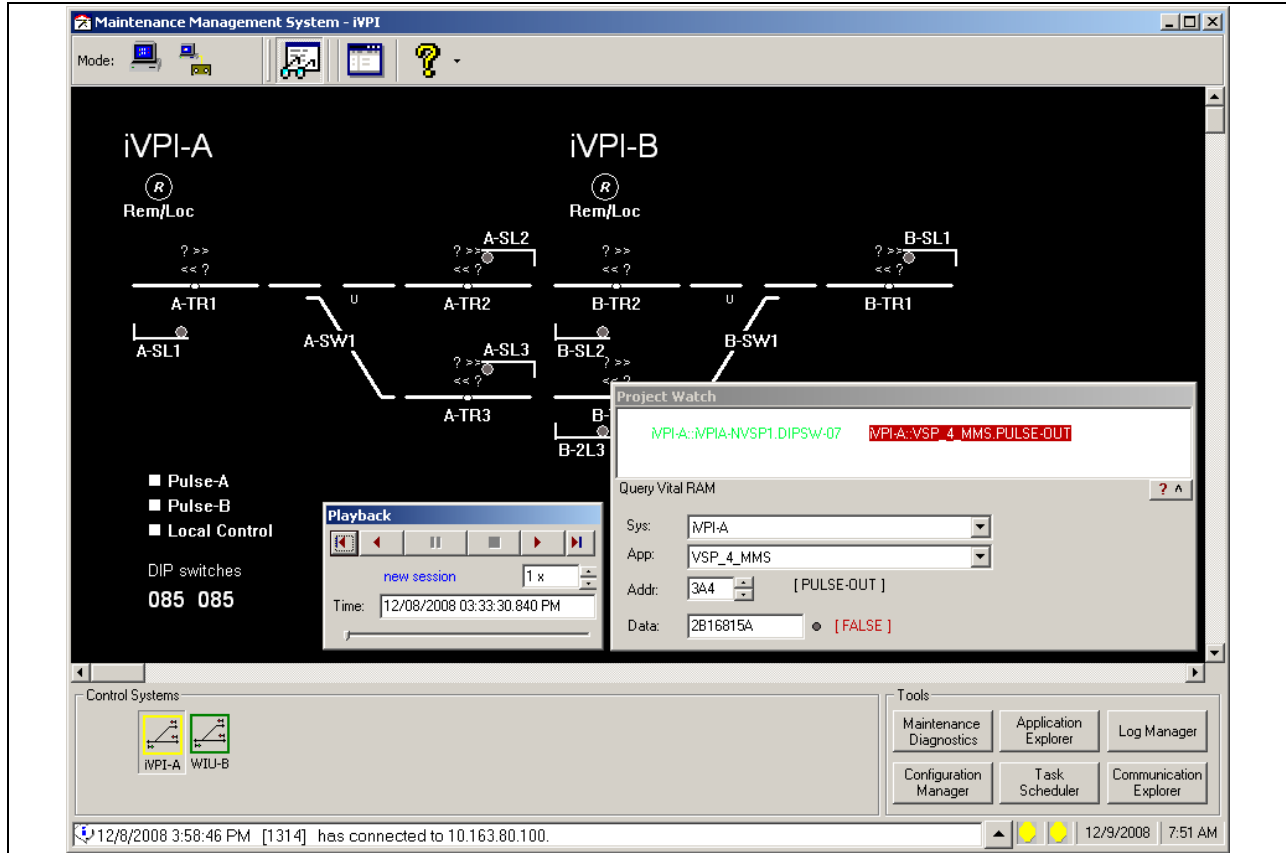

Figure 6-7. Maintenance Management System (MMS)

6.4.2. MMS Fault Detection

In the “REMOTE” setting, the MMS can provide either full-time or part-time monitoring of multiple field device sites simultaneously and can be configured to sound an alarm when a malfunction occurs. When a fault is detected, the MMS automatically diagnoses the problem to indicate the fault or field condition and displays this information to the operator. This helps ensure that proper spares are taken to the site for replacement, minimizing System downtime.

6.4.3. MMS Logging

MMS provides a historical log of errors detected, so that the events leading up to a particular failure can be analyzed later. System Diagnostics allow the user to add comments to the log through keyboard entry. Based on analysis of the log, preventive action can prevent future problems, minimizing System downtime.

6.4.4. MMS Graphical User Interface

MMS uses a graphical user interface, with user input coming from both the mouse and the keyboard. The user interface is designed to minimize confusion and to reduce the learning curve for the user.

6.4.5. MMS Graphical System Diagnostics

MMS provides a graphical view of the entire iVPI System, showing boards with alarms and time-stamped textual diagnostics showing current or historical events. User configurable processing of System commands using instruction files are easily modified using a COTS editor (such as Notepad). Additional comments can be added to the log through keyboard entry.

MMS offers online troubleshooting help with corrective action. The help is written as standard HTML text that can be easily modified using any COTS HTML editor. Changes can be made using a variety of COTS tools including graphics (any standard COTS format such as JPEG, BMP, and TIFF), trouble shooting charts (such as HTML format), text and links to other HTML text.

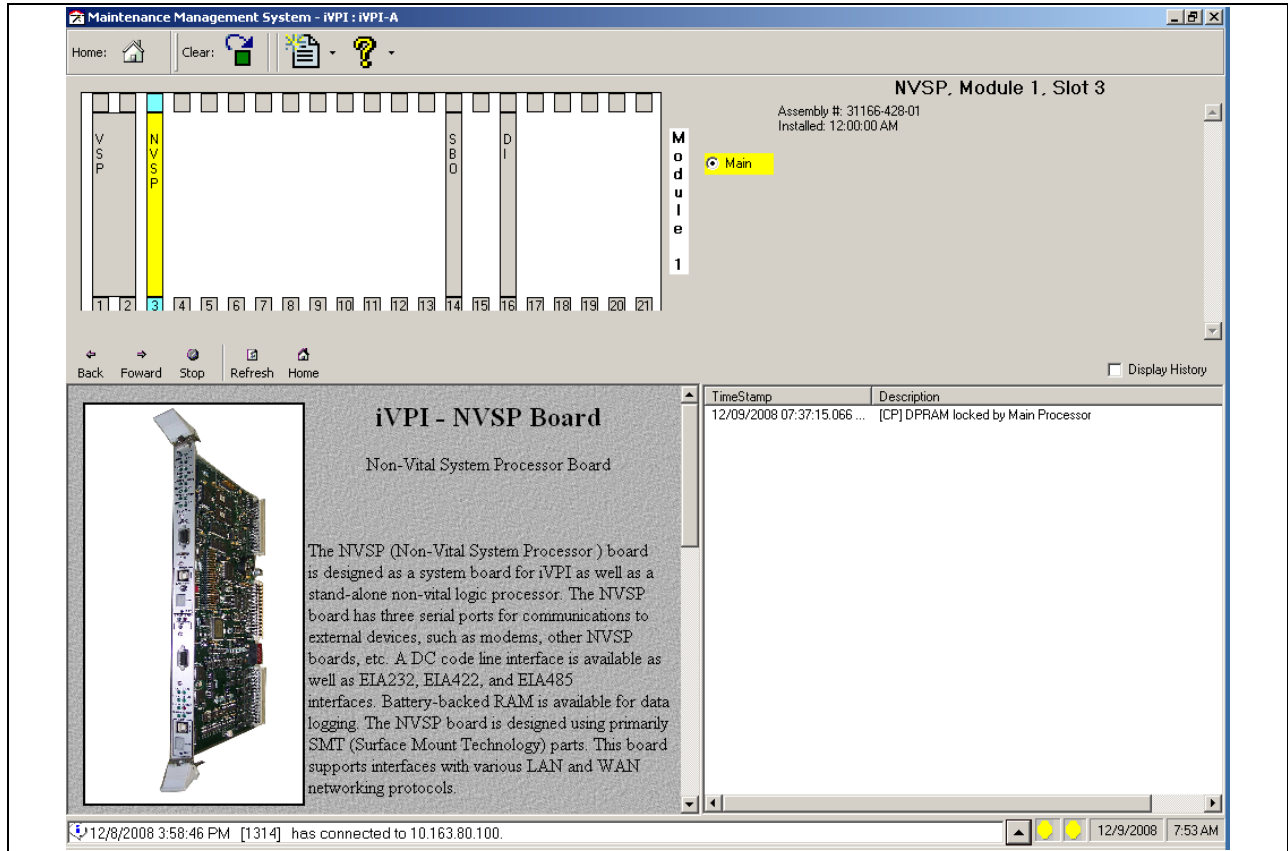

Figure 6–8. MMS Graphical System Diagnostics

6.4.6. MMS Application Explorer

The MMS Application Explorer function provides troubleshooting of the iVPI Systems by accessing variable data obtained through the diagnostic ports. The user may view application parameters and multiple logic, message or I/O variables in real time.

Variables are displayed using their assigned names and their current Boolean or integer values. Application logic statements can be displayed including the current state of the variables that comprise them. Variable states can be logged and saved in human-readable text files, and assigned alarms based on variable state changes.

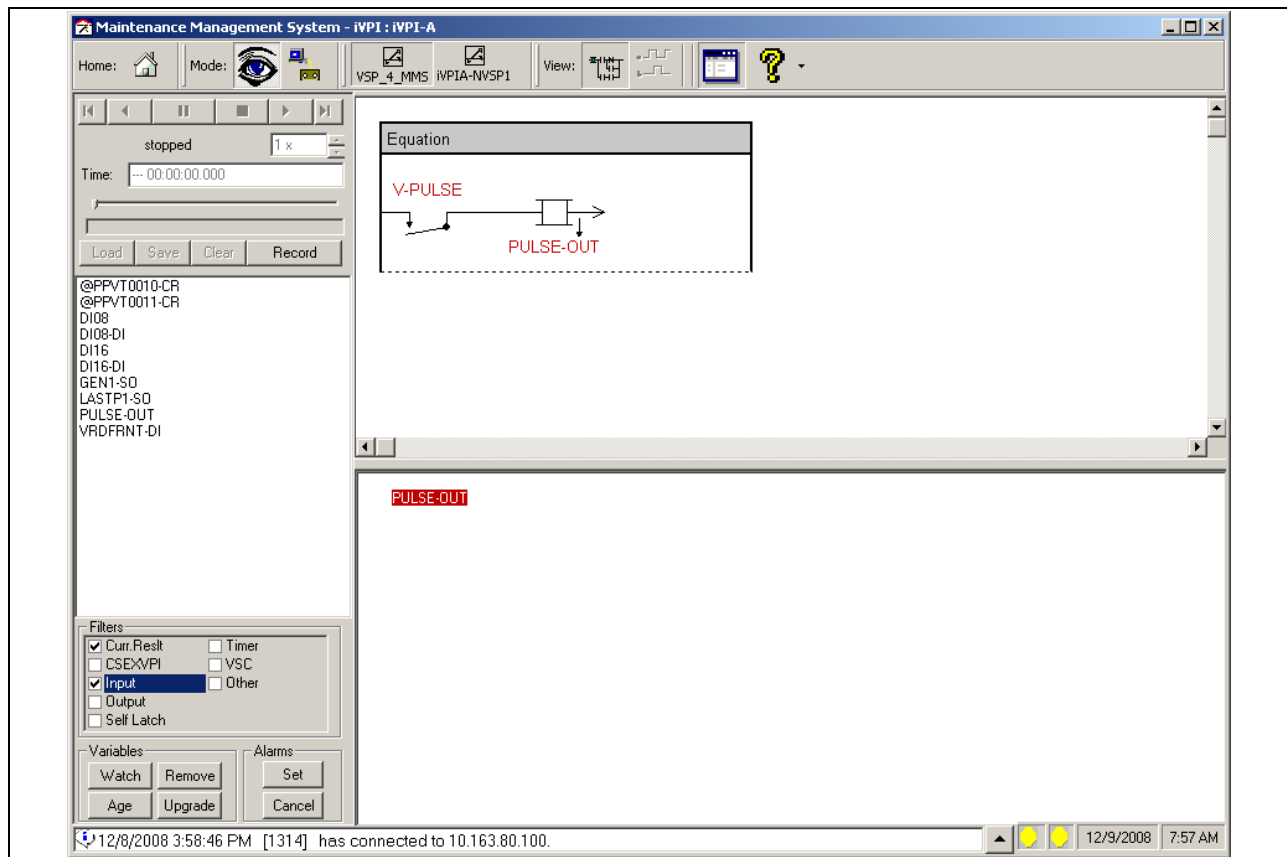

Figure 6–9. MMS Application Explorer (Depicting PLC Ladder Logic Symbols)

6.4.7. MMS Configuration Manager

MMS verifies the software that is installed on the client's iVPI Systems, allowing the user confirmation of what is running prior to making changes.

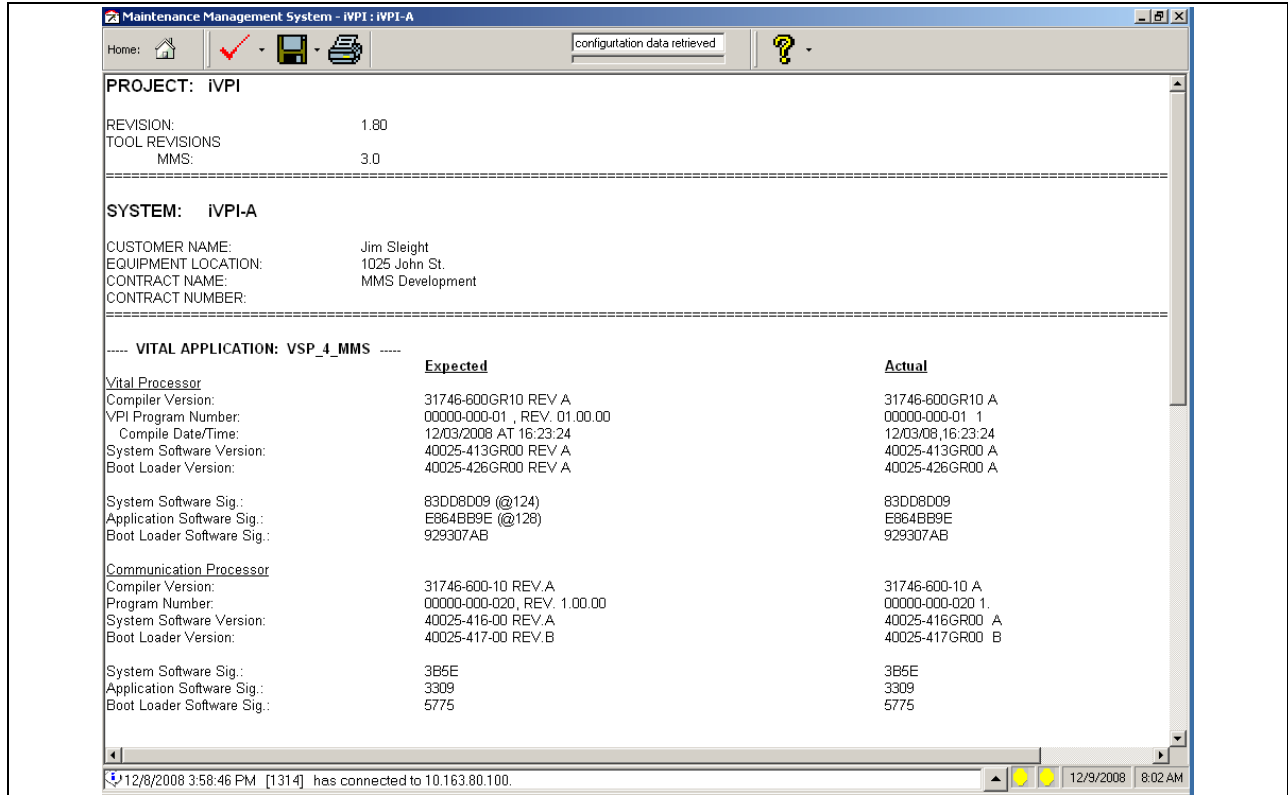

Figure 6–10. MMS Configuration Manager

6.4.8. Communication Explorer – VT 100 Screen

The Communication Explorer - VT100 screen provides a VT100 terminal emulation with macro and capture capabilities.

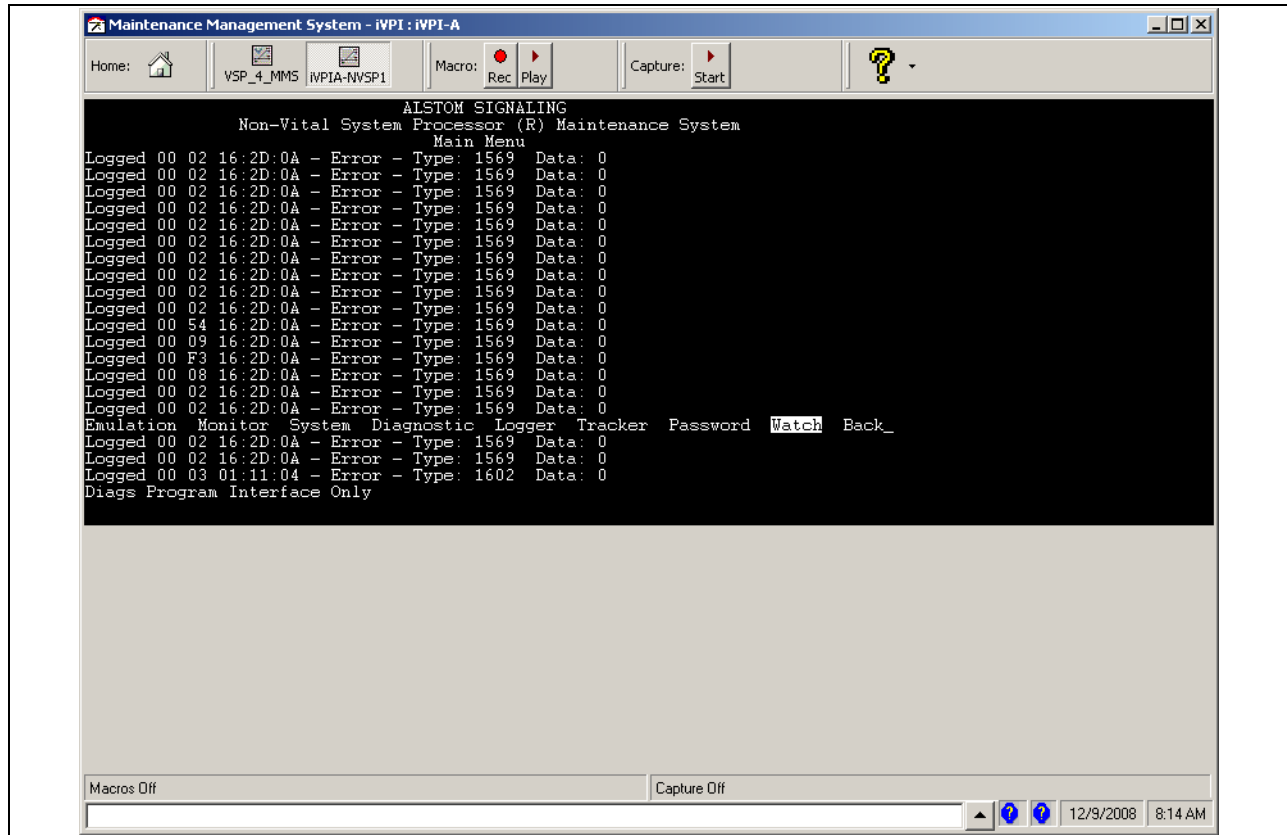

Figure 6–11. MMS Runtime, Communication Explorer – VT100 Screen

6.5. EMBEDDED DATALOGGER

A feature provided by the non-vital Subsystem, the embedded data logger permits viewing of time stamped events in log form or in near real-time chart recorder form. Multiple views are provided.

Key features are:

- View Events Historical, Real-Time
- Filters Unwanted Info
- Saves Data In Nonvolatile Memory
- Timeline and Timestamp Views
- Record time-stamped events to on-board battery-backed memory
- Event capacity is typically several days
- Automatically detect a change to a large number of user-specified application parameters, and record when changes occur in real-time
- On-line help is available to assist the operator

THIS PAGE INTENTIONALLY LEFT BLANK.

7. SECTION 7 – NON-VITAL SYSTEM AND COMMUNICATIONS SOFTWARE

7.1. GENERAL

This section describes the non-vital Subsystem and communications software used in the iVPI System.

7.2. INTRODUCTION

The non-vital Subsystem can support multiple communication/code system protocols simultaneously while performing non-vital input/output operations, application logic functions, train to wayside and wayside to train communications and data logging within the iVPI System. The data logged information is time-stamped and can be viewed real-time, can be selected by the user by run-time, or downloaded for off-line examination. The logic may be written using a combination of Boolean and higher-level programming techniques to control the communications and input/output functions.

7.3. APPLICATION

7.3.1. I/O

Non-vital inputs and outputs can interface to external equipment in order to provide indications to a remote office or to an adjacent location. Outputs are capable of flashing at 60 cycles per second or 120 cycles per second. Examples of inputs and outputs include the following:

- Local Control Panel
 - Switch Machine Normal and Reverse Request Controls
 - Switch Machine Normal and Reverse Position and Lock
 - Indications
 - Signal Request, Fleet and Cancel Controls
 - Signal Aspect and Fleeting Indications
 - Traffic Indications
 - Snow Melter
 - Controls and Indications
- Maintainer Calls
- Battery Power Alarms
- Ground Detection
- Fire Alarm
- Intrusion Alarm
- Room Temperature Monitor
- Track Indications
- System Health
- Redundancy Transfer

7.3.2. Logic

The non-vital logic can be written to perform a wide array of functions, including the following:

- N/X (Entrance/Exit) Interlocking Control
 - Controls provided from a local panel and/or a remote office
- Unilever Interlocking Control
- Remote Office Controls And Indications
- Train-to-Wayside and Wayside-to-Train Communications
 - Train Dwell Control
 - Train Identification
 - Train Berthing
- Automatic Train Operation
- Automatic Route Generation
- Auxiliary Train Tracking
- Interface to Vital Logic

7.3.2.1. Logic Statement Types

- Boolean Equations
- Timer Equations - delays the setting of an equation
- Integer Equations - arithmetic using variables and constants
- Program Flow Control: IF/ELSE, WHILE, GOTO
- User-Defined Subroutines: SUBROUTINE, CALL
- Predefined Subroutines: timer control, format conversion (e.g. Integer-Binary)
- Arrays

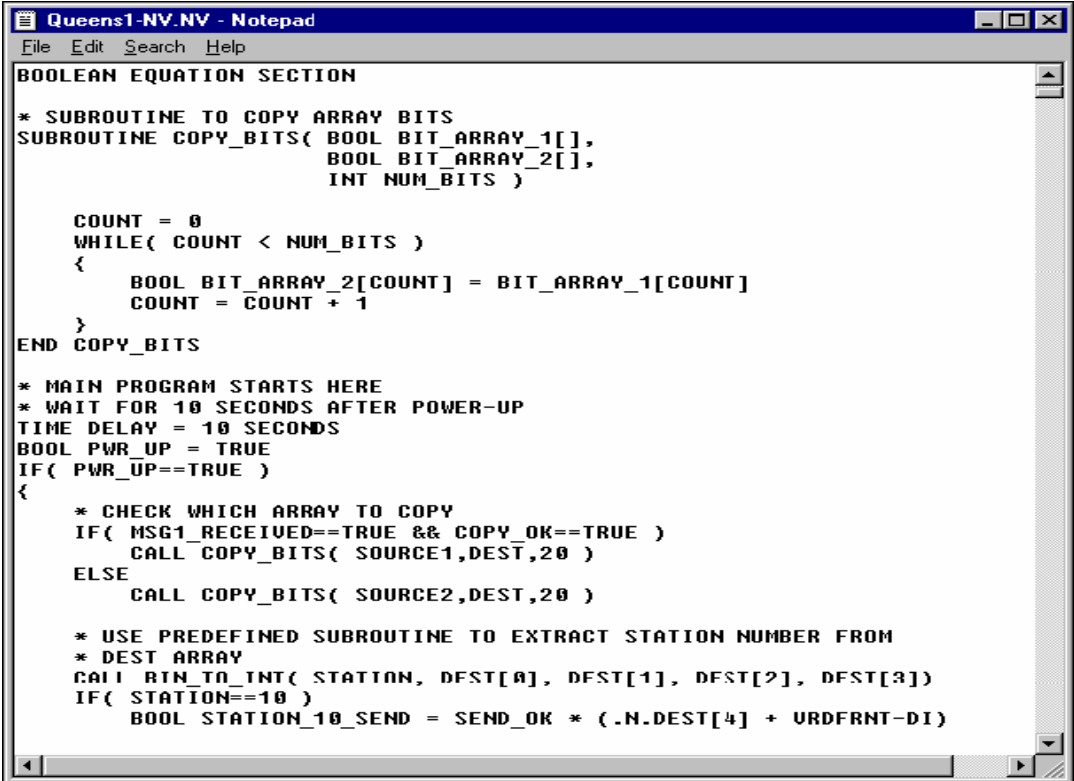

```

Queens1-NV.NV - Notepad
File Edit Search Help
BOOLEAN EQUATION SECTION

* SUBROUTINE TO COPY ARRAY BITS
SUBROUTINE COPY_BITS( BOOL BIT_ARRAY_1[],
                     BOOL BIT_ARRAY_2[],
                     INT NUM_BITS )

    COUNT = 0
    WHILE( COUNT < NUM_BITS )
    {
        BOOL BIT_ARRAY_2[COUNT] = BIT_ARRAY_1[COUNT]
        COUNT = COUNT + 1
    }
END COPY_BITS

* MAIN PROGRAM STARTS HERE
* WAIT FOR 10 SECONDS AFTER POWER-UP
TIME DELAY = 10 SECONDS
BOOL PWR_UP = TRUE
IF( PWR_UP==TRUE )
{
    * CHECK WHICH ARRAY TO COPY
    IF( MSG1_RECEIVED==TRUE && COPY_OK==TRUE )
        CALL COPY_BITS( SOURCE1,DEST,20 )
    ELSE
        CALL COPY_BITS( SOURCE2,DEST,20 )

    * USE PREDEFINED SUBROUTINE TO EXTRACT STATION NUMBER FROM
    * DEST ARRAY
    CALL RTN_TO_INT( STATION, DEST[0], DEST[1], DEST[2], DEST[3])
    IF( STATION==10 )
        BOOL STATION_10_SEND = SEND_OK * (.N.DEST[4] + URDFRNT-DI)
}

```

Figure 7–1. Logic Programming Sample

7.3.3. Communications

iVPI communications include:

- Office - This provides local or interlocking information to a remote office for display while allowing the office to control routing through the interlocking
- Remote Access Terminal
- Automatic Train Dispatch
- Platform Signs
- Intra- or Inter-system Communications - Allow expansion of the System or partitioning of the non-vital Subsystem into multiple processors; also allows neighboring locations to exchange interlocking information

The communications protocols are distributed with the CAAPE software package.

7.4. SYSTEM SOFTWARE INTERFACE MATRIX

See Table 7–1 for Alstom’s library of communications protocols.

Table 7–1. Communications Protocol Library

System Name
ATCS
DataTrain II, VI, VIII
DataTrain VIII over TCP
Genisys
Genisys over TCP
LCE
MCS1
MODBUS Master / Slave
MODBUS Master/Slave over TCP
MODBUS/TCP
SCS128
SCS128DC
S2

THIS PAGE INTENTIONALLY LEFT BLANK.

8. SECTION 8 – MIGRATION STRATEGIES

Because of the nature of the iVPI architecture, installation in the field can accommodate any phased alternative that best suits the need of the customer. From a simple non-vital Subsystem, to a Subsystem with Vital I/O, to a System with full non-vital and Vital I/O and Logic capability can be achieved.

Upgrading legacy installations on Transit applications can be performed as follows:

- Start with installing networking communications to replace older generation line wire carrier based communications systems at much lower Baud Rates
- Add NV Logic to replace older electronic or relay cabinets
- Make provisions for Vital add-on by defining the configuration of the boards populating a Subrack
- Add Vital communications or I/O Interfaces
- Add Vital Logic

For Commuter, Freight or LRT, follow a similar progression including the addition of train detection and cab signaling as required.

THIS PAGE INTENTIONALLY LEFT BLANK.

9. SECTION 9 – REDUNDANCY, AVAILABILITY AND ISOLATION

9.1. GENERAL

This section describes iVPI System redundancy, availability and isolation.

9.2. REDUNDANCY

The iVPI product is constructed to allow for Hot, Warm or Cold standby redundancy. The very high reliability of the electronics permits many applications to be implemented with only one controlling System in many cases.

Historically, failures encountered have been those effecting I/O circuitry. Therefore, full System redundancy is suggested, in line with a high availability System requirement. iVPI insures that all software and hardware is strictly configured and controlled internally, so proof (between the Systems) that the Systems are of the same version and revision is not required. Any change that effects the safety elements of the System is revealed to the user both in reports from the System tools and from the on-line System itself. Any configurability issue results in the effected System functioning in a more restrictive operating state until the failure is repaired.

9.3. AVAILABILITY

Hot Standby configurations can be implemented through the passing of active application parameters indicating the current state of the interlocking. During a transfer initiated due to failure(s) of one System, the standby System seamlessly transitions to control field elements as long as the application parameters are appropriate.

With iVPI's superior diagnostics capability, failures are identified quickly and repaired (MTTR <30min) without effecting the online System.

9.4. ISOLATION

The network capability of iVPI permits I/O to be isolated from the central interlocking logic based on customer preference or in unique harsh environments. The I/O Systems need only provide I/O interface functions. If an I/O System should fail, only that System is affected. This provides a higher level of availability for the interlocking.

The use of isolated Systems is a tradeoff between the amount of hardware and engineering and the installation logistics.

THIS PAGE INTENTIONALLY LEFT BLANK.

10. SECTION 10 – SUMMARY

The new iVPI platform represents a significant movement to a modular, scalable microprocessor control unit that can handle applications as small as a single control point or end of siding to large, complex interlockings. Built on the solid and safe foundation of its predecessor, VPI, the iVPI solution combines the power of Ethernet networking capability with industry standard diagnostic tools to form a powerful new control package offering.

iVPI presents a lower initial investment in material outlay, as well as installation and testing expenses. When combining this with the many value-added after sale savings in serviceability and maintainability, the iVPI platform presents significant cost reductions for both railroad and transit interlocking and wayside applications.

For additional information on this or any other Alstom Signaling Inc. product, including product manuals, contact our Customer Service Line at 800-717-4477 or visit our website at

www.alstomsignalingsolutions.com
--

THIS PAGE INTENTIONALLY LEFT BLANK.

A. APPENDIX A – HISTORY OF THE VPI PRODUCT LINE

A.1. GENERAL

This appendix describes the history of the VPI product line.

A.2. INTRODUCTION

Since its introduction in the 1986, the VPI® product line has undergone continuous evolution and improvement. At its initial introduction, VPI Systems were primarily designed to interface with the traditional Vital 12VDC systems that had become standard in North American Railroads. Families of Vital and non-vital AC I/O boards were also developed for interfacing to AC signals and AC equipment found in North American transit as well as in the international railroad and transit markets. For transit systems with higher degrees of automation, integrated families of Vital cab signal and non-vital train-wayside communication boards were also developed as integral features of the VPI product line.

With the advances of the last two decades in processor and communications technology, VPI Vital and non-vital processor boards have been updated at key points in time for more processing capacity, higher speed communications and protocols, more advanced diagnostics, and more sophisticated man-machine interfaces. VPI point-to-point Vital serial communications was introduced in 1990 and expanded to point-to-multipoint in 1994. VPI Vital communications can be transported over non-vital communication systems including fiber optic systems, both dedicated and multiplexed channels.

All of these updates have been performed in an upward compatible manner. In the recent years, some of the original VPI installations of the 1980's have been upgraded by customers by just a Vital and/or a non-vital processor board upgrade. These upgrades to existing installations incrementally bought these systems up to date with the latest communications technology, the latest advanced diagnostics, and the latest man-machine interfaces that did not exist at the time of the original installation the without necessity of a total system replacement.

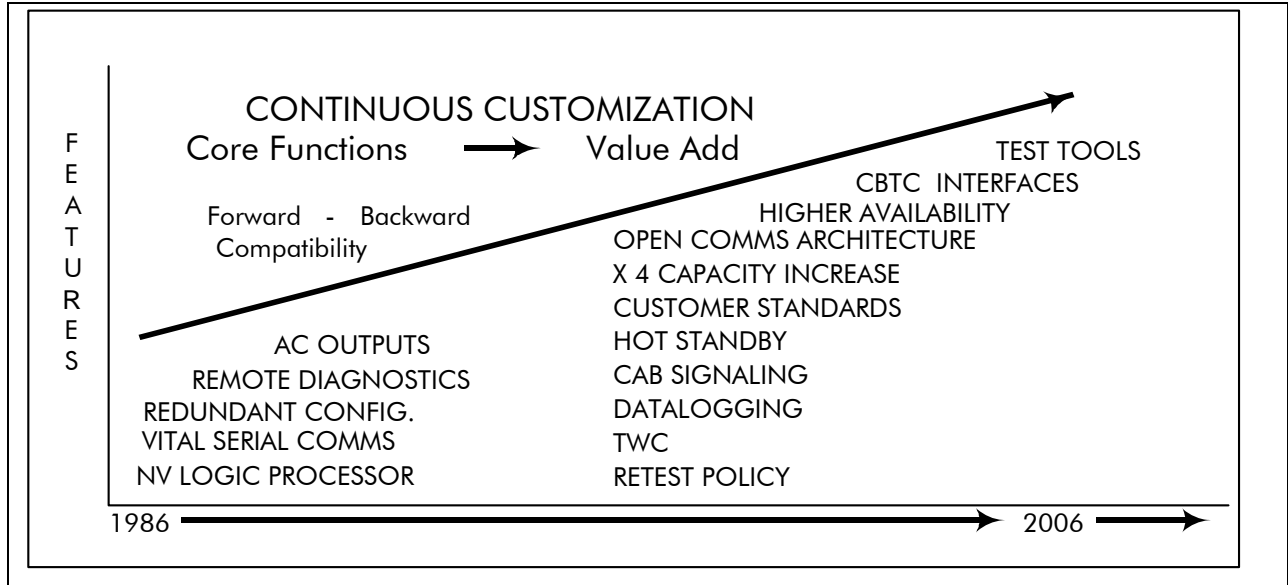

Figure A-1. Continuous Evolution of VPI®

In recent years, the VPI product line has undergone a series of major product upgrades known as VPI II. VPI II upgrades was a five year development plan that bought a number of advanced product enhancements, all of which are upward compatible with the existing installed base to the VPI product line. Several of the early products of this upgrade plan including the LDO board, the VPI II Maintenance Management System [described under Heading 6.4. MAINTENANCE MANAGEMENT SYSTEM (MMS)] and the VSC board which offers increased performance and an integrated network adapter while maintaining the same Vital software algorithms. The current iVPI System is the latest addition to this continuous product improvement program.

A.3. VPI OPERATING CONDITIONS

VPI Systems have seen years of successful operation in the northern reaches of Canada with winter temperatures frequently in the range of -40°C , in the hot, dry deserts of western Colorado and northern Queensland, Australia with summer temperatures in the bungalows approaching $+70^{\circ}\text{C}$ and in the hot, humid climates in the rain forests of Indonesia and Sri Lanka.

VPI Systems have been extensively tested and operated in the extremely harsh EMI environments including lightning that are generally seen within railroad and rail transit systems and especially within electrified railroad transit systems. VPI Systems are designed to operate within the guidelines for systems installed per AREMA Communication and Signal Manual Parts 11.1 to 11.4 regarding Electrical Surge Protection and Lightning Protection. VPI Systems are designed to operate with the traditional lightning protection equipment and proper wiring techniques utilized in the railroad and transit system environments.

More than half of the more than 1500 VPI Systems have been installed on rail and transit properties with electric traction power. These traction power systems have run the gamut of 25 Hz., 50 Hz., and 60 Hz. primary power converted to traction power for 600VDC, 750 VDC and 1000 VDC third rail and for 12.5 KVAC, 25KVAC high voltage catenaries. VPI Systems have been successfully installed and operated on many properties using radio communications for normal operations and for maintenance operations in the 160 MHz, 450 MHz and in the 900 MHz bands. VPI System neither interferes with nor is interfered with by equipment in these bands with normal installation arrangements.

THIS PAGE INTENTIONALLY LEFT BLANK.

**FOR QUESTIONS AND INQUIRIES, CONTACT CUSTOMER SERVICE AT
1-800-717-4477
OR
WWW.ALSTOMSIGNALINGSOLUTIONS.COM**

**ALSTOM SIGNALING INC.
1025 JOHN STREET
WEST HENRIETTA, NY 14586**