



VPI<sup>®</sup> II

## Vital Processor Interlocking Control System

## Chassis Configuration

Copyright © 2008 Alstom Signaling Inc.





VPI<sup>®</sup> II

## Vital Processor Interlocking Control System

## Chassis Configuration

Copyright © 2008 Alstom Signaling Inc.

Chassis Configuration Manual  
**Alstom Signaling Inc.**

P2511B, Volume 2, Rev. September 2008, Printed in U.S.A.



## LIST OF EFFECTIVE PAGES

### P2511B, Volume 2, VPI® II Chassis Configuration Manual

ORIGINAL ISSUE DATE: September 2008

CURRENT CHANGE AND DATE: September 2008

PAGE	CHANGE OR REVISION LEVEL
Cover	Sep/08
Title page	Sep/08
Preface	Sep/08
i thru vi	Sep/08
1-1 thru 1-14	Sep/08
2-1 thru 2-4	Sep/08
3-1 thru 3-72	Sep/08
4-1 thru 4-8	Sep/08

THIS PAGE INTENTIONALLY LEFT BLANK.

**PREFACE**

**NOTICE OF CONFIDENTIAL INFORMATION**

Information contained herein is confidential and is the property of Alstom Signaling Incorporated. Where furnished with a proposal, the recipient shall use it solely to evaluate the proposal. Where furnished to customer, it shall be used solely for the purposes of inspection, installation or maintenance. Where furnished to a supplier, it shall be used solely in the performance of the contract. The information shall not be used or disclosed by the recipient for any other purposes whatsoever.

**FOR QUESTIONS AND INQUIRIES, CONTACT CUSTOMER SERVICE AT  
1-800-717-4477  
OR  
WWW.ALSTOMSIGNALINGSOLUTIONS.COM**

**ALSTOM SIGNALING INC.  
1025 JOHN STREET  
WEST HENRIETTA, NY 14586**

**REVISION LOG**

<b>Revision</b>	<b>Date</b>	<b>Description</b>	<b>By</b>	<b>Checked</b>	<b>Approved</b>
0	September 2008	Original issue	MAS	KW	NI

THIS PAGE INTENTIONALLY LEFT BLANK.

## **ABOUT THE MANUAL**

This manual is intended to describe the Alstom Vital Processor Interlocking Control System, (VPI<sup>®</sup> II) chassis configuration, including part numbers and chassis illustrations. This manual is part of a 5 volume set of manuals. The set is summarized in Section 1.

The information in this manual is arranged into sections. The title and a brief description of each section follow:

**Section 1 – VPI II CHASSIS:** This section provides an overview of VPI II system chassis related options including part numbers and a brief explanation of their application.

**Section 2 – CIRCUIT BOARD KEYING:** This section provides the keying information for the VPI II circuit boards.

**Section 3 – MODULES AND CABLES:** This section provides examples of VPI II hardware, associated equipment, and connector plugs.

**Section 4 – SPECIAL TOOLS:** This section shows the special tools used for the VPI II chassis.

THIS PAGE INTENTIONALLY LEFT BLANK.

## **MANUAL SPECIAL NOTATIONS**

In the Alstom manuals, there are three methods used to convey special informational notations to the reader. These notations are warnings, cautions, and notes. Both warnings and cautions are readily noticeable by boldface type two lines beneath the caption.

### Warning

A warning is the most important notation to heed. A warning is used to tell the reader that special attention needs to be paid to the message because if the instructions or advice is not followed when working on the equipment then the result could be either serious harm or death. The sudden, unexpected operation of a switch machine, for example, or the technician contacting the third rail could lead to personal injury or death. An example of a typical warning notice follows:

#### **WARNING**

DISCONNECT MOTOR ENERGY WHENEVER WORKING ON SWITCH LAYOUT OR SWITCH MACHINE. UNEXPECTED OPERATION OF MACHINE COULD CAUSE INJURY FROM OPEN GEARS, ELECTRICAL SHOCK, OR MOVING SWITCH POINTS.

### Caution

A caution statement is used when an operating or maintenance procedure, practice, condition, or statement, which if not strictly adhered to, could result in damage to or destruction of equipment. A typical caution found in a manual is as follows:

#### **CAUTION**

Turn power off before attempting to remove or insert circuit boards into a module. Boards can be damaged if power is not turned off.

### Note

A note is normally used to provide minor additional information to the reader to explain the reason for a given step in a test procedure or to just provide a background detail. An example of the use of a note follows:

#### **NOTE**

A capacitor may be mounted on the circuit board with a RTV adhesive. Use the same color RTV.

THIS PAGE INTENTIONALLY LEFT BLANK.

## TABLE OF CONTENTS

Topic	Page
<b>1. SECTION 1 – VPI II CHASSIS .....</b>	<b>1-1</b>
1.1. INTRODUCTION .....	1-1
1.2. MANUAL SET ORGANIZATION .....	1-1
1.3. PLUG COUPLED CHASSIS.....	1-2
1.3.1. Case .....	1-3
1.3.2. Cables .....	1-4
1.4. DIRECT WIRED CHASSIS .....	1-5
1.4.1. Case .....	1-6
1.4.2. Cables .....	1-7
1.5. COVERS .....	1-7
1.6. INTERCONNECTIONS .....	1-8
1.6.1. P1 Interconnections.....	1-8
1.6.2. P2 Interconnection.....	1-8
1.6.3. P3 Interconnection.....	1-9
1.7. CABLE AND BACK PLANE CONNECTORS .....	1-10
1.8. POWER SUPPLY.....	1-13
1.9. MISCELLANEOUS .....	1-14
<b>2. SECTION 2 – CIRCUIT BOARD KEYING.....</b>	<b>2-1</b>
2.1. GENERAL .....	2-1
<b>3. SECTION 3 – MODULES AND CABLES.....</b>	<b>3-1</b>
3.1. INTRODUCTION .....	3-1
3.2. GENERAL .....	3-1
3.3. SYSTEM MODULE EXAMPLE.....	3-3
3.4. SYSTEM MODULE CIRCUIT .....	3-18
3.5. CABLE, MOTHERBOARD JUMPER, P/N 38216-402-01.....	3-19
3.6. MOTHERBOARD, CONTINUOUS BACKPLANE CIRCUIT, P/N 31166-166-01 .....	3-20
3.7. MOTHERBOARD ASSEMBLY (B1), P/N 59473-743-01 .....	3-25
3.8. MAIN BUS BOARD ASSEMBLY, P/N 31166-201-07 .....	3-28
3.9. VITAL AND NON-VITAL MOTHERBOARD INTERFACE CONNECTIONS ...	3-29
3.10. FILTER BOARD, 5V, P/N 59473-819-01 .....	3-32
3.11. CABLE, BOARD EDGE CONNECTOR, P/N 38216-392-01 THRU -06.....	3-34
3.12. CABLE, NON-VITAL I/O, P/N 38216-393-01 THRU -03.....	3-36
3.13. CABLE, VITAL I/O, P/N 38216-394-01 THRU -03.....	3-38
3.14. CABLE, SYSTEM BUS, P/N 38216-395-01 THRU -10 .....	3-42
3.15. CABLE, MODULE TO MODULE, P/N 38216-403-01 .....	3-44
3.16. CABLE, EXPANSION, P/N 38216-404-01 THRU -08.....	3-45
3.17. CABLE, NON-VITAL I/O, P/N 38216-497-01 THRU -03.....	3-46
3.18. CONNECTOR, PLUG, 14-WAY, P/N 58920-113-00 .....	3-48
3.19. CONNECTOR, PLUG, 28-WAY, P/N 58920-124-00 .....	3-50
3.20. CONNECTOR, PLUG, 50-WAY, P/N 58920-112-00 .....	3-52

## TABLE OF CONTENTS (CONT.)

Topic	Page
3.21. CONNECTOR, PLUG, 75-WAY, P/N 58920-116-00 .....	3-53
3.22. RECEPTACLE KEYING PLAN FOR SYSTEM MODULE, P/N 31038-249-003	55
3.23. 28-WAY CONNECTOR COMPLETE, P/N 42758-127-01 THRU -25 .....	3-57
3.24. 50-WAY CONNECTOR COMPLETE, P/N 42758-093-01 THRU -25 .....	3-59
3.25. 75-WAY CONNECTOR COMPLETE, P/N 42758-134-01 THRU -25 .....	3-61
3.26. DC/DC CONVERTER, P/N 42560-273-01 THRU -08 .....	3-63
3.27. EXTENDER BOARDS .....	3-69
3.28. RELAY, B1 NEUTRAL, REGULAR RELEASE, 100 OHM (USED WITH VRD BOARD), P/N 56001-787-05 .....	3-72
<b>4. SECTION 4 – SPECIAL TOOLS .....</b>	<b>4-1</b>
4.1. GENERAL .....	4-1

---

## LIST OF FIGURES

Description	Page
Figure 1–1. Plug Coupled Chassis.....	1–2
Figure 1–2. Plug Coupled Chassis Components.....	1–2
Figure 1–3. Example Extended System .....	1–4
Figure 1–4. Direct Wired Chassis.....	1–5
Figure 2–1. Registration Keying of Circuit Board .....	2–1
Figure 2–2. Registration Keying Numbering.....	2–2
Figure 3–1. Example Board Placement for Single Chassis VPI II System .....	3–1
Figure 3–2. Example VPI II Module Chassis .....	3–2
Figure 3–4. System Module Circuit .....	3–18
Figure 3–5. Cable, Motherboard Jumper, P/N 38216-402-01 .....	3–19
Figure 3–6. Motherboard, Continuous Backplane Circuit, P/N 31166-166-01 .....	3–20
Figure 3–8. Main Bus Board Assembly, P/N 31166-201-07 .....	3–28
Figure 3–9. Filter Board, 5V, P/N 59473-819-01 .....	3–32
Figure 3–10. Circuit, Filter Board, 5V, P/N 59473-819-01.....	3–33
Figure 3–11. Cable, Board Edge Connector, P/N 38216-392-01 thru -06.....	3–34
Figure 3–12. Wire Tables for Cables, P/N 38216-392-01 thru -06 .....	3–35
Figure 3–13. Cable, Non-Vital I/O, P/N 38216-393-01 thru -03.....	3–36
Figure 3–14. Wire Tables for Cables, P/N 38216-393-01, -02 and -03 .....	3–37
Figure 3–15. Cable, Vital I/O, P/N 38216-394-01 thru -03.....	3–38
Figure 3–16. Wire Tables for Cable, P/N 38216-394-01 .....	3–39
Figure 3–17. Wire Tables for Cable, P/N 38216-394-02 .....	3–40
Figure 3–18. Wire Tables for Cable, P/N 38216-394-03 .....	3–41
Figure 3–19. Cable, System Bus, P/N 38216-395-01 thru -10 .....	3–42
Figure 3–20. Cable, Module to Module, P/N 38216-403-01 .....	3–44
Figure 3–21. Cable, Expansion, P/N 38216-404-01 thru -08.....	3–45
Figure 3–22. Cable, Non-Vital I/O, P/N 38216-497-01 thru -03.....	3–46
Figure 3–23. Wire Tables for Cable, P/N 38216-497-01 thru -03 .....	3–47
Figure 3–24. Connector, Plug, 14-Way, P/N 58920-113-00 .....	3–48
Figure 3–25. Connector, Plug, 14-Way Mounting Assembly, AD61-41 .....	3–49
Figure 3–26. Connector, Plug, 28-Way, P/N 58920-124-00 .....	3–50
Figure 3–27. Connector, Plug, 28-Way, Mounting Assembly, AD61-31 .....	3–51
Figure 3–28. Connector, Plug, 50-Way, P/N 58920-112-00 .....	3–52
Figure 3–29. Connector, Plug, 75-Way, P/N 58920-116-00 .....	3–53
Figure 3–30. Connector, Plug, 50-Way and 75-Way, Mounting Assembly, AD61-30 .....	3–54
Figure 3–36. Extender Board, P/N 59473-744-01 .....	3–69
Figure 3–37. Extender Board, P/N 59473-745-01 .....	3–70
Figure 3–38. Extender Board, P/N 59473-746-01 .....	3–71
Figure 3–39. Relay, B1 Neutral, Regular Release, 100 Ohm (Used with VRD Board), P/N 56001-787-05.....	3–72

## LIST OF FIGURES (CONT.)

Description	Page
Figure 4–1. Extractor, B Relay Terminal, P/N 59688-000-00 .....	4–3
Figure 4–2. Extractor, Gold Leaf, P/N 59688-048-00 .....	4–3
Figure 4–3. Extractor, Type M, P/N 59688-005-00.....	4–4
Figure 4–4. Extractor, Gold Leaf, P/N 59688-009-00 .....	4–4
Figure 4–5. Insertion/Extractor, #24-20, P/N 59688-018-00.....	4–4
Figure 4–6. Thomas and Betts Shield Hand Crimp Tool WT740 with Crimping Die....	4–5
Figure 4–7. Hand Crimp Tool, Type M #22-20, P/N 24745-048-00 .....	4–5
Figure 4–8. Hand Crimp Tool, P/N 24745-074-00 .....	4–6
Figure 4–9. Hand Crimp Tool, Type C, P/N 24745-087-00 .....	4–6
Figure 4–10. Hand Crimp Tool, Twin Leaf, P/N 24745-126-00 .....	4–6
Figure 4–11. Hand Crimp Tool, Ring #22-16, P/N 24745-145-00 .....	4–7
Figure 4–12. Hand Crimp Tool, P/N 24745-149-00.....	4–7

---

## LIST OF TABLES

Description	Page
Table 1–1. Plug Coupled Chassis Part Numbers .....	1–3
Table 1–2. Direct Wired Chassis Part Numbers .....	1–6
Table 1–3. Interface PCB Cover Part Numbers .....	1–7
Table 1–4. Ribbon Cables for System Bus P1 Interconnections .....	1–8
Table 1–5. Ribbon Cables .....	1–9
Table 1–6. Cable Complete, P/N 38216-392.....	1–10
Table 1–7. Cable Complete, P/N 38216-393.....	1–11
Table 1–8. Cable Complete, P/N 38216-394.....	1–11
Table 1–9. Cable Complete, P/N 38216-497.....	1–11
Table 1–10. Plug Coupler Mating Connectors (AMP Type 'M') .....	1–12
Table 1–11. Melcher DC-DC Converters.....	1–13
Table 1–12. Miscellaneous Components .....	1–14
Table 2–1. Vital and Non-Vital PC Board Keying .....	2–3
Table 3–1. System Module Parts List, P/N 31038-249-XX.....	3–11
Table 3–2. Motherboard Assembly (B1) Parts List, P/N 59473-743-01.....	3–27
Table 3–3. Vital and Non-Vital Motherboard Interface Connections.....	3–29
Table 3–4. Motherboard Power Supply Interface .....	3–31
Table 4–1. Special Wiring Tools.....	4–2

---

THIS PAGE INTENTIONALLY LEFT BLANK.

# 1. SECTION 1 – VPI II CHASSIS

## 1.1. INTRODUCTION

This manual provides an overview of chassis related options including part numbers and a brief explanation of their application. Be aware that the chassis configurations provided are examples only, refer to the book of plans for your location to determine the components used in your configuration. Note that all part numbers are Alstom numbers unless otherwise noted.

See P2511B, Volume 1 for capacity overview and hardware criteria.

## 1.2. MANUAL SET ORGANIZATION

This manual is part of a 5 volume set supporting the VPI II system. The set is organized as follows:

- Volume 1, Installation, Operation, and Theory Manual includes general overview of the field installation and setup of the VPI II system; including capacity guidelines and allowable VSC/CSEX3 board combinations, system operation, and theory of operation.
- Volume 2, Chassis Configuration, is this document. It describes the chassis configuration including cables and power supplies.
- Volume 3, Vital Subsystem, includes the Vital subsystem board drawings, signature headers and proms, and board reference data.
- Volume 4, Non-Vital Subsystem, includes non-vital subsystem board drawings and board reference data.
- Volume 5, Maintenance and Troubleshooting, describes system maintenance and troubleshooting, including discussion of diagnostics and references for the applicable software and hardware manuals.

### 1.3. PLUG COUPLED CHASSIS

The VPI II plug coupled chassis includes internal cable harness assemblies. These assemblies connect the VPI II PCB I/O point(s) to a series of AMP type M-series plug couplers, mounted on the rear panel of the chassis. The rear panel also contains a 14-pin type M-series plug coupler for the 5 VDC power connection and provisions for up to four 60-way ribbon cable connectors for connecting to expansion chassis.



Figure 1–1. Plug Coupled Chassis

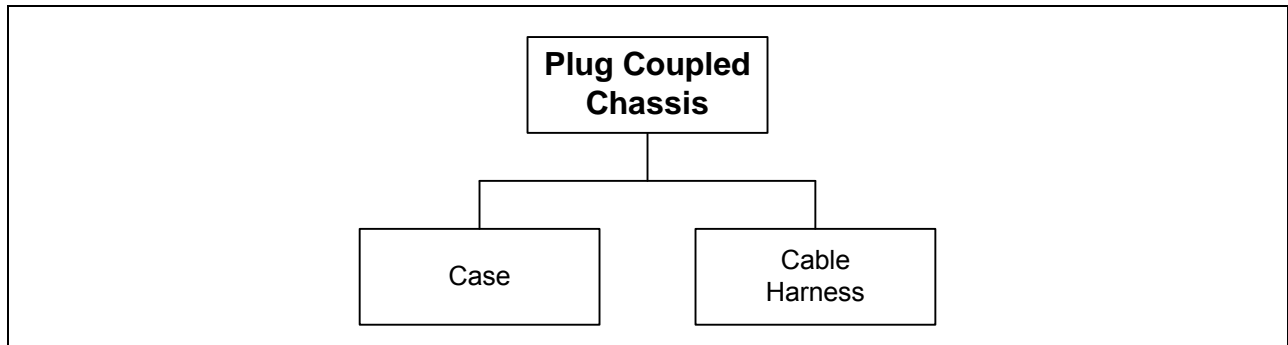

Figure 1–2. Plug Coupled Chassis Components

1.3.1. Case

The VPI II plug coupled chassis is available in two basic case configurations. One to four chassis can be used to complete a single system. The system may be a mixture of the two types of chassis. The two basic types are the split motherboard and the continuous motherboard that busses the center connector (P2) of the printed circuit boards together. Each chassis contains 21 printed circuit board slots.

The split motherboard version of the chassis is configured to connect the P2 connector traces from chassis slots one through five together and slots 6 through 21 together. Since the VPI II system uses the P2 connector as the I/O bus, this allows Vital and non-vital I/O to be housed in the same chassis. For example, the first five chassis slots could be used to house non-vital I/O and the non-vital processor. Slots from 6 to 21 could contain Vital I/O along with the Vital I/O controller (I/O bus).

**NOTE**

Other system boards may also be required to configure a proper operating system and several other arrangements could be possible.

The continuous motherboard version of the plug coupled module connects all the slots (1 –21) of the P2 connector together. This requires that all the I/O housed in the module be either Vital or non-vital. In addition, a CSEX3 board can be housed in this module with Vital I/O as long as no non-vital I/O is also housed in the module.

An extra deep, plug coupled chassis is offered to provide more space for internal cables such as the 38216-497-XX cable assemblies. For those systems with large numbers of I/O's this makes access to the back of the motherboard and 5 VDC power filter easier.

Table 1–1. Plug Coupled Chassis Part Numbers

Description	Part Number
Plug coupled chassis with split motherboard (5/16 slots), 5 VDC power filter and 38216-404 Bus Extension Cable	31506-015-01
Plug coupled chassis with split motherboard (5/16 slots), 5 VDC power filter and 38216-404 Bus Extension Cable - special	31506-016-01
Plug coupled chassis with continuous motherboard (21 slots), 5 VDC power filter and 38216-404 Bus Extension Cable	31506-015-11
Extra deep plug coupled chassis with rear cover, split motherboard, and 5 VDC power filter	31506-015-15
Extra deep plug coupled chassis with rear cover, continuous motherboard, and 5 VDC power filter	31506-015-16

### 1.3.2. Cables

The chassis require specific cable assemblies based on the PCB configuration. Up to four 60-way ribbon cables, located on the rear panel, are required for the main system bus, see Table 1–4. These cables connect the main system boards together. The number of positions or slots required for this cable is dependant upon the number of main boards being installed. The boards connected by this main bus are CSEX3, VRD, CPU II, IOB and VSC. The VRD board takes 2 slots.

Cable harnesses are also required to connect the PCB edge connectors to the plug couplers on the rear cover of the chassis. There are 21 available plug coupler locations on the rear panel. Blank plates are used to cover the unused locations. There are several variations of output and input cables to provide a variety of arrangements of plug couplers and board configurations.

To connect up to four VPI II systems, bus extension and module cables are used. See Figure 1–3 for an example arrangement. In this example P/N 38216-404-xx cable is used in the system module connected off the top connector of the I/O bus board to "extend" the system bus to the other modules. The same series cable is used in each extension module to create the system busses. An I/O bus, CSEX, or VSC board can be installed in any one of the extension modules to continue the extension. The 4-foot cables (P/N 38216-403-01 in the example) are used to connect between the modules. The 38216-395-xx is only used in the system module for the system bus. A 31166-201-07 System Bus board could be used instead and supports 7-slots.

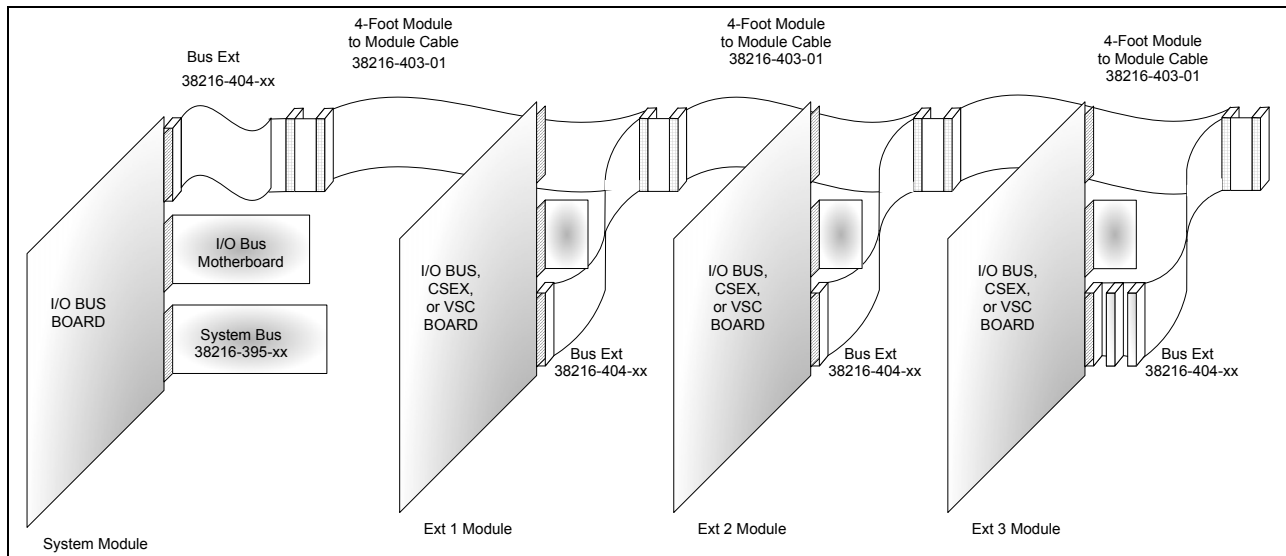

Figure 1–3. Example Extended System

#### 1.4. DIRECT WIRED CHASSIS

The direct wired chassis is configured to allow the I/O wiring to be economical by directly inserting wire into the PCB edge connectors in the chassis. This chassis configuration does not allow for quick removal of the chassis from a wired rack. However, all the PCBs can be removed and no active electronic components are left in the chassis. This version is intended for applications where the rack housing this chassis provides a plug-coupled connection to the other interlocking equipment.

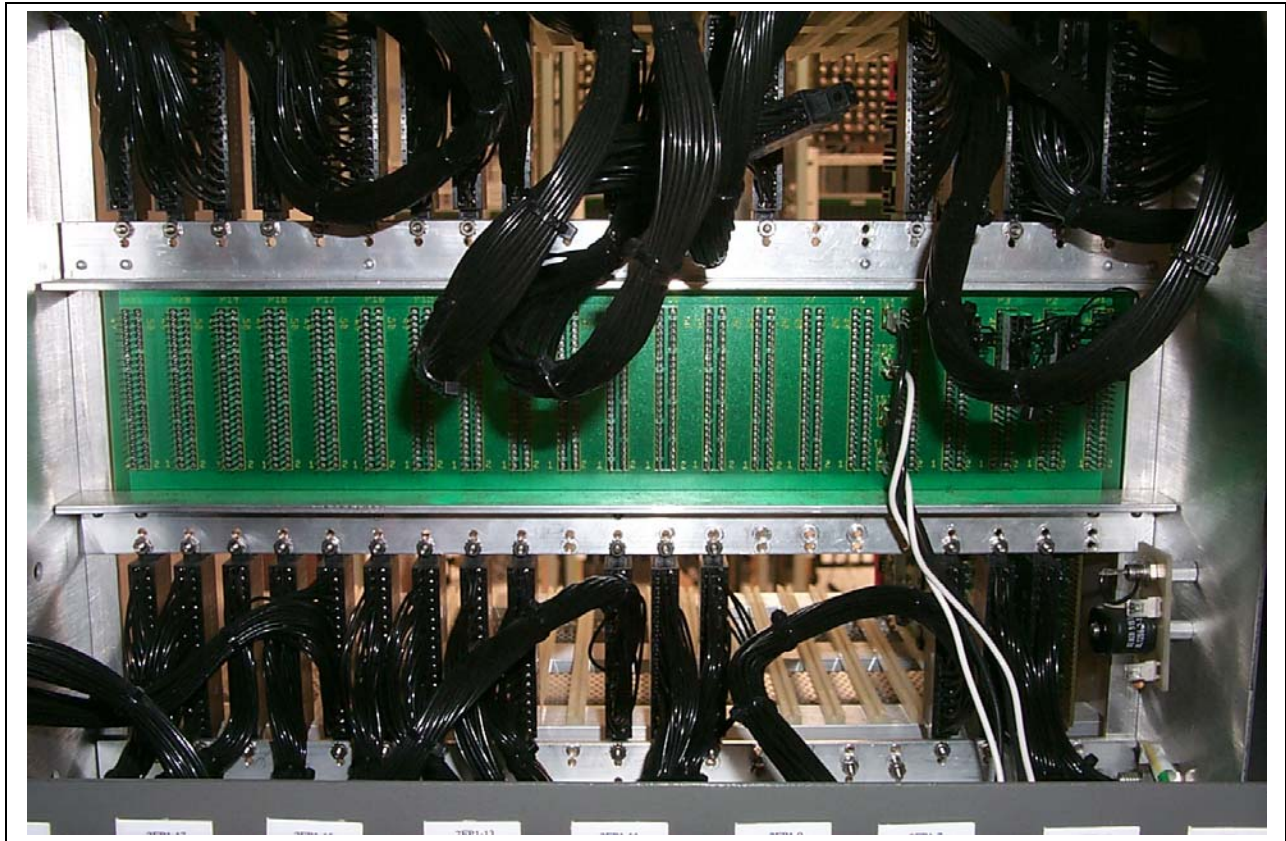

Figure 1–4. Direct Wired Chassis

1.4.1. Case

The VPI II direct wired chassis is available in two basic case configurations. One to four chassis can be used to complete a single system. The system may be a mixture of the two types of chassis. The two basic types are the split motherboard and the continuous motherboard that busses the center connector (P2) of the printed circuit boards together. All chassis contain 21 printed circuit board slots.

The split motherboard version of the chassis is configured to connect the P2 connector traces from chassis slots one through five together and slots 6 through 21 together. Since the VPI II system uses the P2 connector as the I/O bus, this allows Vital and non-vital I/O to be housed in the same chassis. For example, the first five chassis slots could be used to house non-vital I/O and the non-vital processor. Slots from 6 to 21 could contain Vital I/O along with the Vital I/O controller (I/O bus).

**NOTE**

Other system boards may also be required to configure a proper operating system and several other arrangements could be possible.

This chassis can also be supplied with an optional rear panel. This panel is used to provide connection points for diagnostic equipment connections; chassis to chassis ribbon cable connections and power supply connections.

The continuous motherboard version of the direct wired module connects all the slots (1 –21) of the P2 connector together. This requires that all the I/O housed in the module be either Vital or non-vital. In addition, a CSEX3 board can be housed in this module with Vital I/O as long as no non-vital I/O is also housed in the module.

Table 1–2. Direct Wired Chassis Part Numbers

Description	Part Number
Direct wired chassis with rear panel, split motherboard, and 5 VDC power filter Note: use with 38216-404-KN bus ext. cables	31506-015-02
Direct wired chassis with split motherboard, 5 VDC power filter, NO rear panel or rear cover	31506-015-03
Direct wired chassis with rear panel, continuous motherboard, and 5 VDC power filter	31506-015-12
Direct wired chassis with continuous motherboard, 5 VDC power filter, NO rear panel or rear cover	31506-015-13
Direct wired chassis with rear panel, split motherboard, and 5 VDC power filter Note: use with 38216-504-KN bus ext. cables	31506-015-14

### 1.4.2. Cables

The chassis require specific cable assemblies based on the PCB configuration. Up to four 60-way ribbon cables, located on the rear panel, are required for the main system bus, see Table 1–4. These cables connect the main system boards together. The number of positions or slots required for this cable is dependant upon the number of main boards being installed. The boards connected by this main bus are CSEX3, VRD, CPU II, IOB and VSC. The VRD board takes 2 slots.

### 1.5. COVERS

The VPI II chassis can be supplied with optional covers. The front cover is a hinged aluminum cover on which the PCB label is generally mounted. The chassis can also be supplied with either a top or bottom screen or both. This screen is generally used to prevent items from falling into the PCB area of the equipment.

Table 1–3. Interface PCB Cover Part Numbers

Description	Part Number
Front Cover	58605-043-02
Top/Bottom Screen Cover	50253-354-00

## 1.6. INTERCONNECTIONS

### 1.6.1. P1 Interconnections

P1 interconnection is the System Bus (connects CPU II, VRD, VSC, IOB, CSEX3).

Table 1–4. Ribbon Cables for System Bus P1 Interconnections

Part Number	Description
38216-395-01	6 slot
38216-395-02	5 slot
38216-395-03	2 slot (2 inch)
38216-395-04	2 slot (18 inch)
38216-395-05	7 slot
38216-395-06	8 slot
38216-395-07	9 slot
38216-395-08	10 slot
38216-395-09	11 slot
38216-395-10	12 slot

System Bus PC Board (P/N 31166-201-07) duplicates the functionality of ribbon cable P/N 58216-395-01.

### 1.6.2. P2 Interconnection

Split motherboard P/N 59473-743-01 has a bus split between slots 5 and 6. It is used with a mixed chassis containing a combination of Vital and non-vital boards or a chassis containing two subsystems of non-vital boards.

#### **NOTE**

Do not use Motherboard Jumper Cable P/N 38216-402-01 to create a backplane for all Vital and all non-vital chassis; use the continuous motherboard (P/N 31166-166-01).

Continuous backplane P/N 31166-166-01 has no bus split. It is used with either an all Vital I/O chassis or an all non-vital I/O chassis

### 1.6.3. P3 Interconnection

The main chassis P3 interconnection via ribbon cables is used for interfacing between the main chassis (I/O Bus board only) and extender chassis. A system can consist of multiple chassis by extending the system bus from the main chassis to the extender chassis.

Table 1–5. Ribbon Cables

<b>Main Chassis Connector</b>	<b>Ext Mod Edge Connector</b>	<b>Part Number</b>
1 Connector	1 Connector	38216-404-01
1 Connector	2 Connector	38216-404-02
2 Connector	1 Connector	38216-404-03
2 Connector	2 Connector	38216-404-04
2 Connector	3 Connector	38216-404-05
1 Connector	3 Connector	38216-404-06
2 Connector	6 Connector	38216-404-07
1 Connector	6 Connector	38216-404-08

## 1.7. CABLE AND BACK PLANE CONNECTORS

Cable P/N 38216-392-00 is the cable that runs from board edge to rear plug couplers (Amp type 'M').

Table 1–6. Cable Complete, P/N 38216-392

<b>Board</b>	<b>Board Edge Connector (Qty) Description</b>	<b>Back Plane Connector (Qty) Description</b>	<b>Coupler Row</b>	<b>Part Number</b>
Vital Relay Driver	(1) 36-pin Board Edge	(1) 28-way Plug Coupler	Bottom	38216-392-01
CSEX3,VSC	(1) 36-pin Board Edge	(1) 50-way Plug Coupler	Top	38216-392-02
Vital Relay Driver	(1) 36-pin Board Edge	(1) 28-way Plug Coupler	Middle	38216-392-03
CSEX3, VSC	(1) 36-pin Board Edge	(1) 50-way Plug Coupler	Middle	38216-392-04
Vital Relay Driver	(1) 36-pin Board Edge	(1) 28-way Plug Coupler	Top	38216-392-05
CSEX3, VSC	(1) 36-pin Board Edge	(1) 50-way Plug Coupler	Bottom	38216-392-06
CRG	(1) 20-pin Board Edge	(1) 28-way Plug Coupler	Bottom	38216-536-01
CRG	(1) 20-pin Board Edge	(1) 28-way Plug Coupler	Middle	38216-536-02
CRG	(1) 20-pin Board Edge	(1) 28-way Plug Coupler	Top	38216-536-03

### **NOTE**

38216-392-01, -03, -05 are 4-conductor cables; 38216-392-02, -04, -06 are 36-conductor cables.

Table 1–7. Cable Complete, P/N 38216-393

Board	Board Edge Connector (Qty) Description	Back Plane Connector (Qty) Description	Part Number
Non-Vital I/O	(2) 36-pin Board Edge	(1) 50-pin Plug Coupler, 10.5"	38216-393-01
Non-Vital I/O	(2) 36-pin Board Edge	(1) 50-pin Plug Coupler, 6.875"	38216-393-02
Non-Vital I/O	(2) 36-pin Board Edge	(1) 50-pin Plug Coupler, 2.5"	38216-393-03

Table 1–8. Cable Complete, P/N 38216-394

Board	Board Edge Connector (Qty) Description	Back Plane Connector (Qty) Description	Part Number
Vital Output	(2 × 3) 36-pin Board Edge	(3) 28-way Plug Coupler	38216-394-01
Vital Input	(2 × 2) 36-pin Board Edge	(3) 28-way Plug Coupler	38216-394-02
Vital Output	(2 × 2) 36-pin Board Edge	(3) 28-way Plug Coupler	38216-394-03

Table 1–9. Cable Complete, P/N 38216-497

Board	Board Edge Connector (Qty) Description	Back Plane Connector (Qty) Description	Coupler Row	Part Number
Non-Vital I/O	(2) 36-pin Board Edge	(1) 75-way Plug Coupler	Bottom	38216-497-01
Non-Vital I/O	(2) 36-pin Board Edge	(1) 75-way Plug Coupler	Middle	38216-497-02
Non-Vital I/O	(2) 36-pin Board Edge	(1) 75-way Plug Coupler	Top	38216-497-03

Table 1–10. Plug Coupler Mating Connectors (AMP Type 'M')

<b>Mating Connector</b>	<b>Part Number</b>	<b>AMP #</b>
28-way Plug Coupling	58920-124-00	205689-2
50-way Plug Coupling	58920-112-00	203622-2
75-way Plug Coupling	58920-116-00	201331-1

**NOTE**

When any of these connectors are used with Cable Assemblies 38216-392-01, -03, -05, only four pins should be placed in the mating connector (do not insert extra pins). This is necessary to maintain Vital spacing.

## 1.8. POWER SUPPLY

The complete power supply assembly comes on a 'B2' mounting plate. Various Melcher DC-DC converters are used, depending on the power requirements.

Table 1–11. Melcher DC-DC Converters

<b>Power Supply</b>	<b>Input Voltage</b>	<b>Output Voltage/Current</b>	<b>Part Number</b>
(1) Single IN/Single OUT	8-35 VDC	5.1 VDC/8A	42560-273-01
(2) Single IN/Single OUT	8-35 VDC each	5.1 VDC/8A	42560-273-02
(1) Single IN/Single OUT	20-100 VDC	5.1 VDC/25A	42560-273-03
(1) Single IN/Dual OUT	8-35 VDC	15 VDC/1.7A, 15 VDC/1.7A	42560-273-04
(2) Single IN/Single OUT	8-35 VDC each	12 VDC/4A	42560-273-05
(1) Single IN/Single OUT	8-35 VDC	12 VDC/4A	42560-273-06
(1) Single IN/Dual OUT	8-30 VDC	12VDC/4A, 5VDC/8A	42560-273-07
Single IN/Single OUT	7-30 VDC	5VDC/8A	42560-273-08
Single IN/Dual OUT	8-30 VDC	5.1VDC/8A	42560-287-01
(1) Single IN/Dual OUT	8-30 VDC	5.1VDC/25A	42560-287-02
Single IN/Single OUT	8-35 VDC	12 VDC/10A	42560-287-03
Single IN/Single OUT	8-35 VDC	12 VDC/4A	42560-287-05
Single IN/Single OUT	8-35 VDC	5.1VDC/20A	42560-287-09
Single IN/Single OUT	8-35 VDC	5.1VDC/8A	42560-287-10

## 1.9. MISCELLANEOUS

Table 1–12. Miscellaneous Components

Description	Part Number
Extender Board for IOB, CPU II	59473-744-01
Extender Board for DI, SBO, DBO, ACO, LDO, NVI, NVIDSW, NVO, NVOAC, NVR, NVTWC-MOD, NVTWC-MUX, NVTWC-FSK, CRG	59473-745-01
Extender Board for boards VRD, CSEX3, VSC, FSVT	59473-746-01
Diagnostic Control Cable	38216-452-00
Diagnostic Control Panel	42560-285-01
5 Volt Filter Board	59473-819-01
100 Ohm Type B Relay for VRD	56001-787-05
14-way connector	58920-113-00
Amp Terminal Crimp Tool (AMP No. 90285-1)	24745-149-00
Amp Terminal Crimp Tool (AMP No. 583649-6)	24745-074-00
Amp Terminal Extraction Tool (AMP No. 465195-1)	59688-003-00

## 2. SECTION 2 – CIRCUIT BOARD KEYING

### 2.1. GENERAL

This section provides the keying information for the VPI II circuit boards. All circuit boards used in the VPI II system are mechanically keyed to a specific slot in the VPI II module.

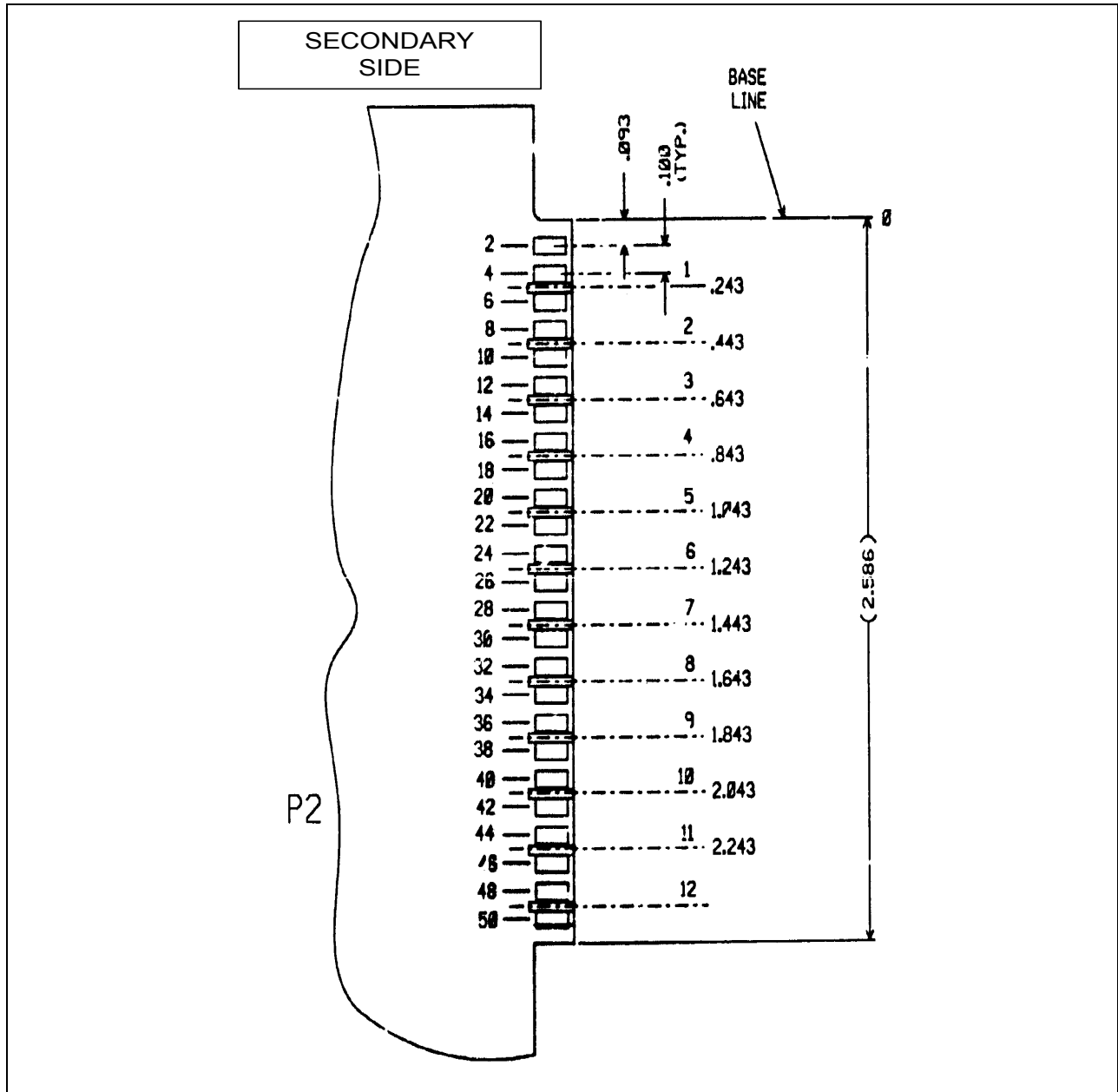
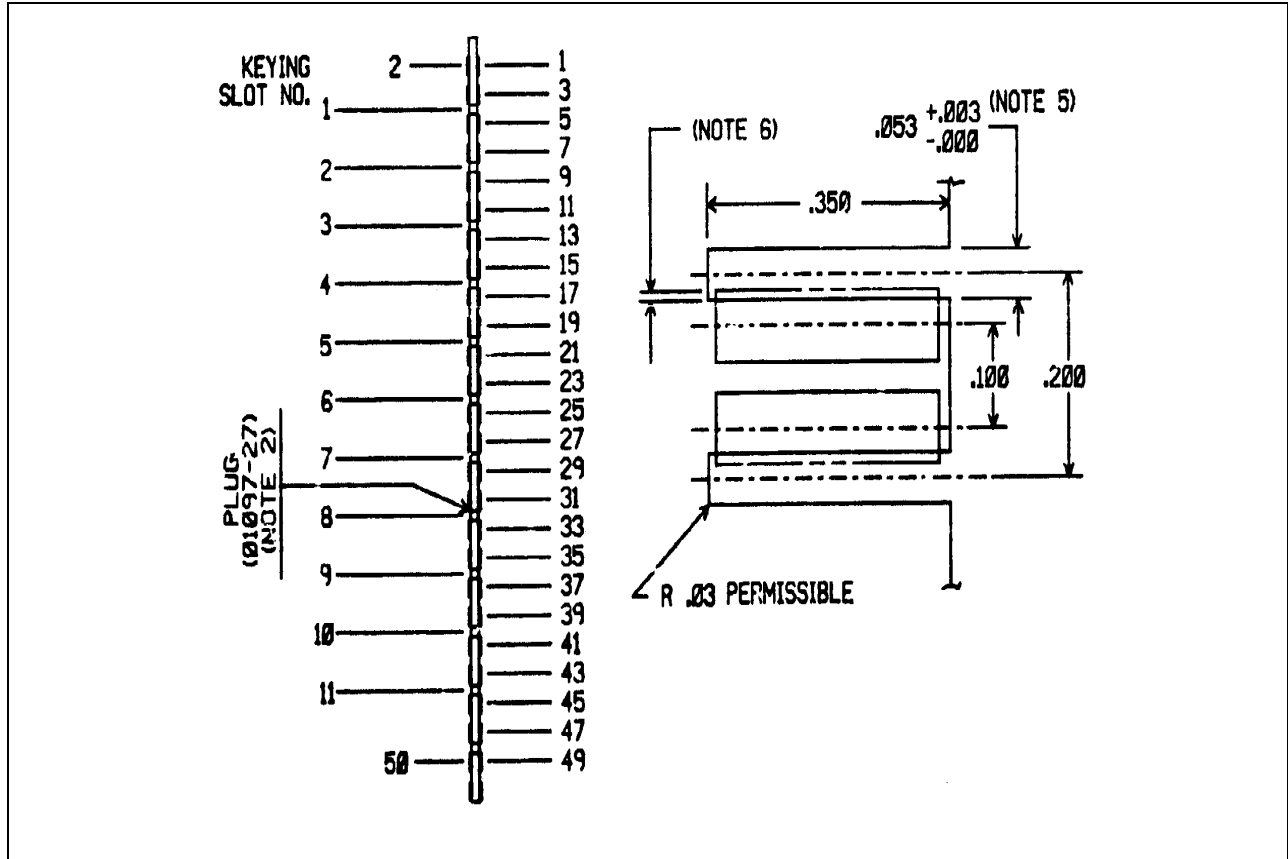

Figure 2–1. Registration Keying of Circuit Board



- Note 1: Spaces 1 through 11 only are used for registration.
- Note 2: Insert plug (01097-027), narrow end first as far as it goes into keying plug slot.
- Note 3: Minimum finger dimension after slotting -0.050 inches.
- Note 4: Numbering shown from secondary side. P1 and P3 not shown.
- Note 5: Keying slots to be milled in per dimensions shown.
- Note 6: Code indicates the location of keys. See registration code chart.

Figure 2-2. Registration Keying Numbering

Vital and non-vital PC board keying information is provided in Table 3–1.

Table 2–1. Vital and Non-Vital PC Board Keying

<b>Board Type</b>	<b>Keying Code</b>
CPU II (P/N 31166-374-01, -02)	2-4-5
VRD (P/N 59473-740-02)	3-4
VSC (P/N 59473-939-10 to -14)	2-8
CRG (P/N 31166-261-03)	2-11
CRG (P/N 31166-261-04)	3-10
IOB (P/N 59473-827-01)	2-3
DI (P/N 59473-867-01 , -02)	1-2
DI (P/N 59473-867-03)	1-8
DI (P/N 59473-867-04, -05)	3-7
DI (P/N 59473-867-07)	5-11
SBO (P/N 59473-739-01, -02)	1-3
DBO (P/N 59473-747-01, -02)	1-4
DBO (P/N 59473-747-03)	4-8
DBO-50V (P/N 59473-977-01, -02)	2-10
LDO (P/N 59473-749-02, -03, -04)	1-5
LDO2 (P/N 31166-340-01, -02)	8-10
ACO (P/N 59473-937-01, -02, -03)	1-10
FSVT (P/N 59473-894-01, -02)	3-6
CSEX3 (P/N 31166-175-02, -03)	1-3-5-7-8-11
NVI (P/N 59473-757-02)	1-6
NVI (P/N 59473-757-03)	2-6
NVIDSW (P/N 31166-276-01, -02)	6-10
NVIDSW (P/N 31166-276-03, -04)	6-9
NVO (P/N 59473-785-01, -03)	1-7
NVO (P/N 59473-785-02, -04, -05)	2-7
NVOAC (P/N 59473-936-01, -02)	1-9
NVO-SNK (P/N 31166-123-01)	1-4
NVR (P/N 31166-238-01)	7-9
NVR (P/N 31166-238-02)	7-10

Table 2–1. Vital and Non-Vital PC Board Keying (Cont.)

<b>Board Type</b>	<b>Keying Code</b>
NVTWC-MOD (P/N 31166-099-02)	6-8
NVTWC-MUX (P/N 31166-100-02)	5-10
NVTWC-FSK (P/N 31166-119-02 to -06)	6-11

### 3. SECTION 3 – MODULES AND CABLES

#### 3.1. INTRODUCTION

This section provides examples of VPI II hardware, associated equipment, and connector plugs. See P2511B, Volume 3 for Vital boards and P2511B, Volume 4 for non-vital boards.

#### 3.2. GENERAL

Illustrations of example VPI II supporting hardware, except for circuit boards, appear on the following pages. The illustrations are arranged in this general order: cases, motherboards, internal and external module cables, connector plugs, extender boards, and Vital VRD relay.

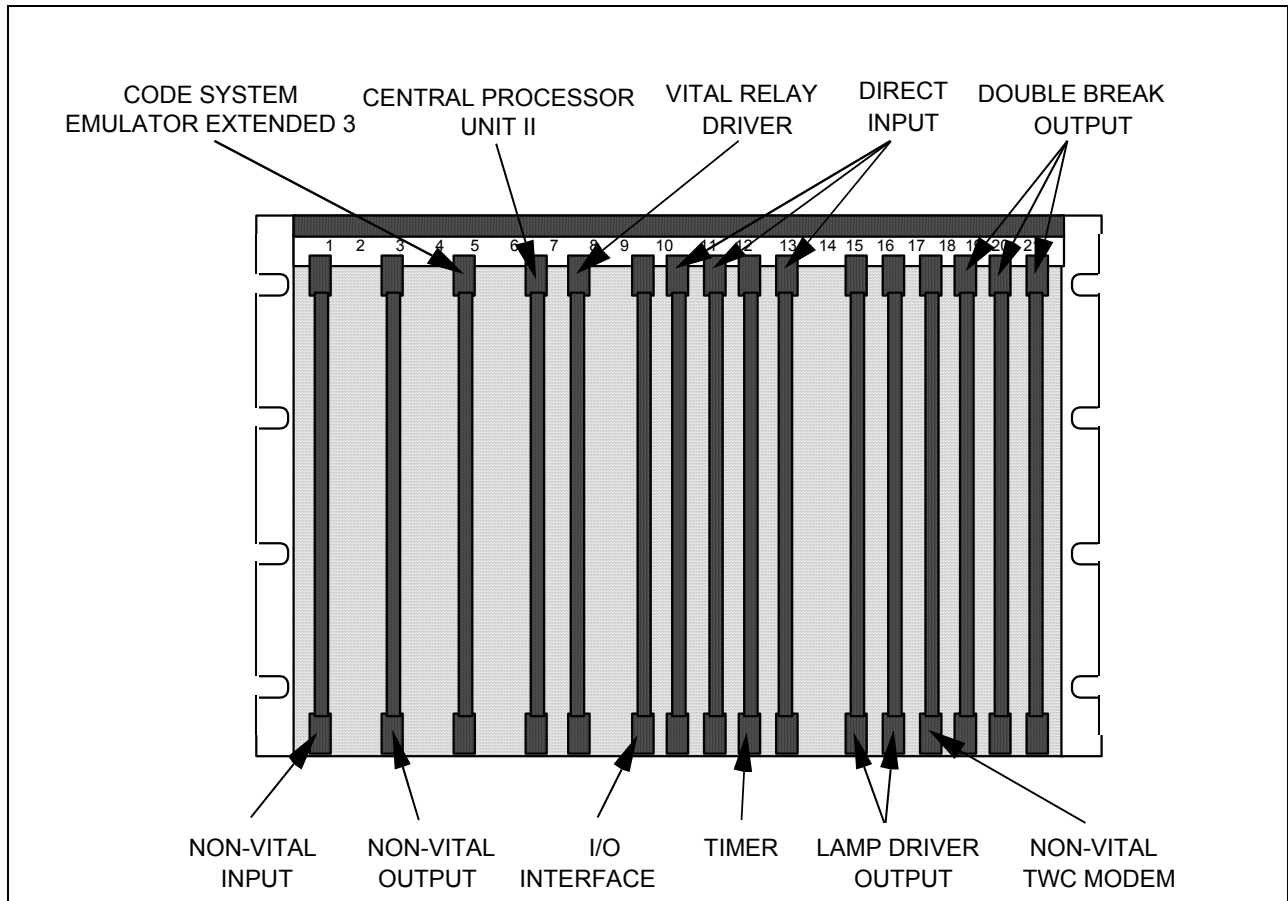

Figure 3–1. Example Board Placement for Single Chassis VPI II System

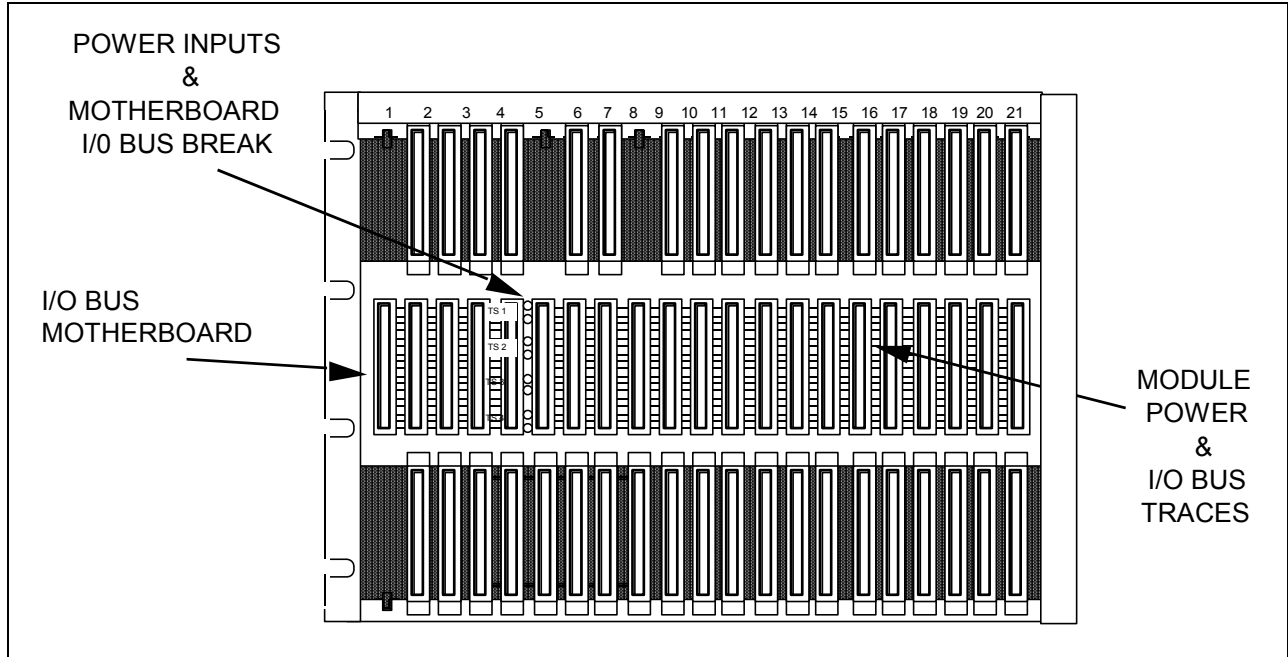

Figure 3-2. Example VPI II Module Chassis

3.3. SYSTEM MODULE EXAMPLE

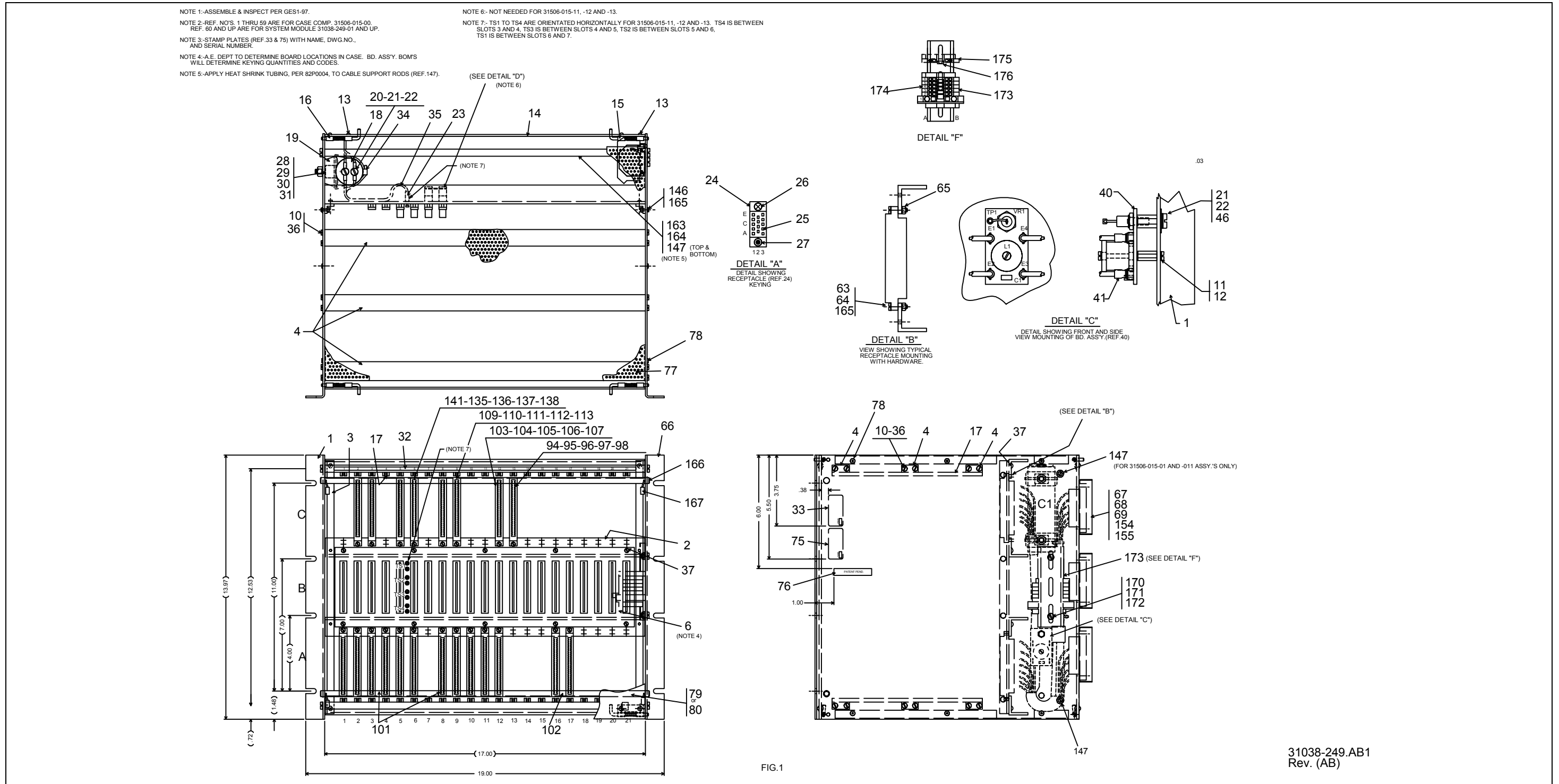

Figure 3-3. System Module, P/N 31038-249-00 (Sheet 1 of 4)

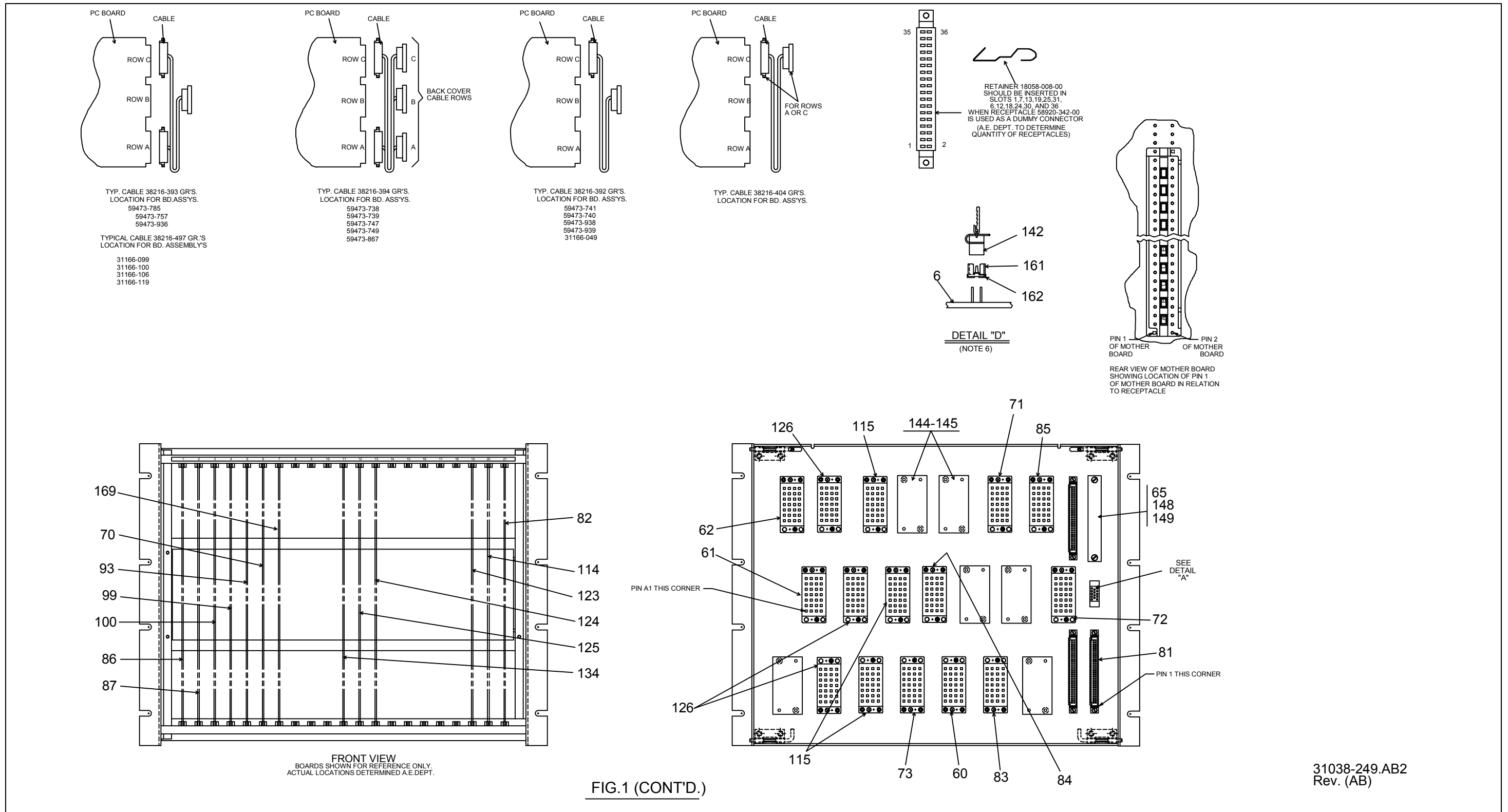
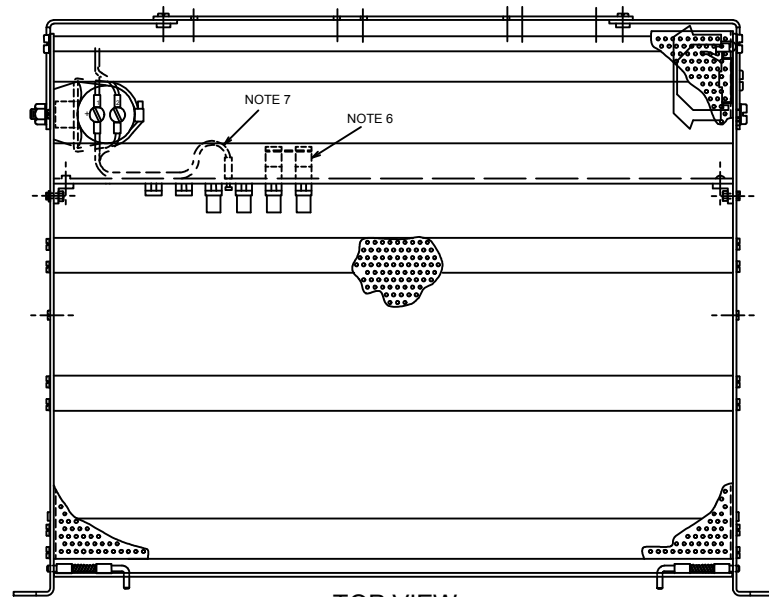
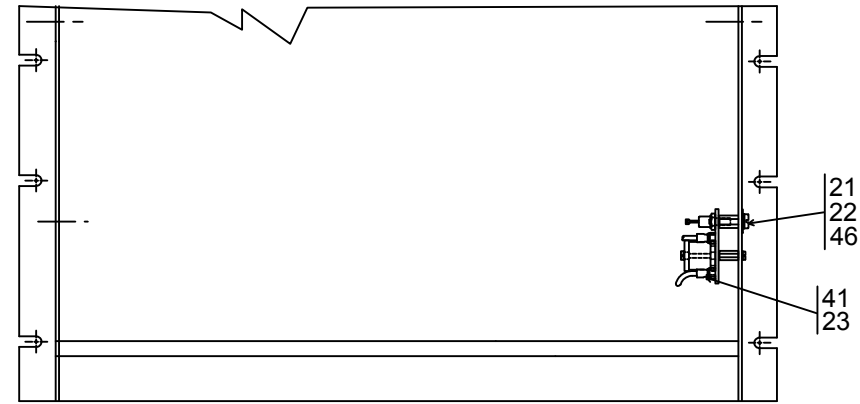

Figure 3-3. System Module, P/N 31038-249-00 (Sheet 2 of 4)

NOTE: BACK PLATE 31038-249-02 ONLY.



TOP VIEW  
FIG.2  
OTHERWISE SAME AS FIG.1



BACK VIEW

FIG.3  
OTHERWISE SAME AS FIG.2

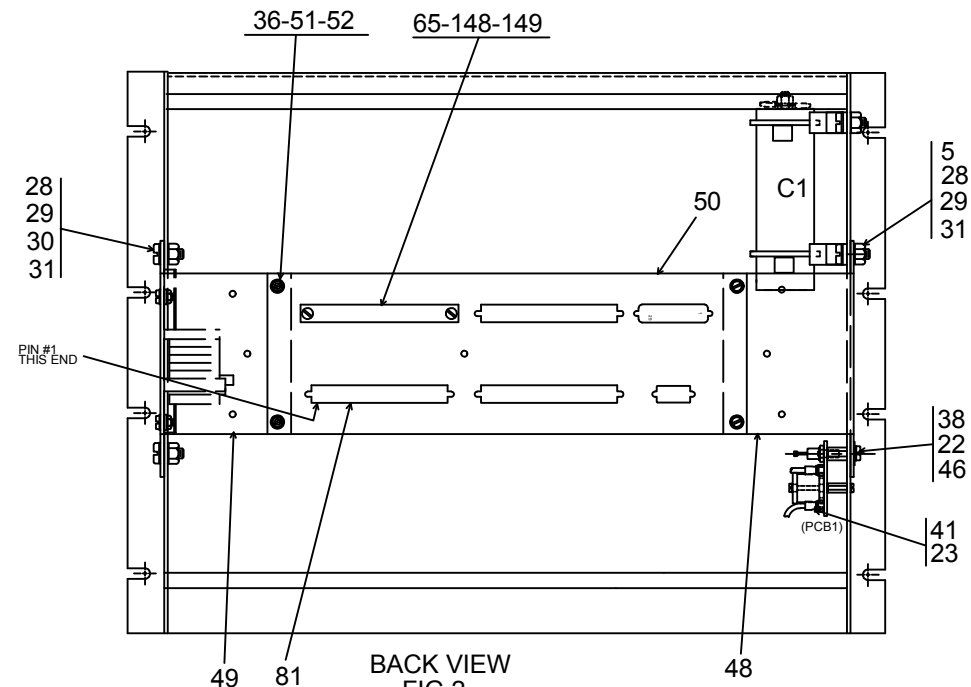

BACK VIEW  
FIG.2  
OTHERWISE SAME AS FIG.1

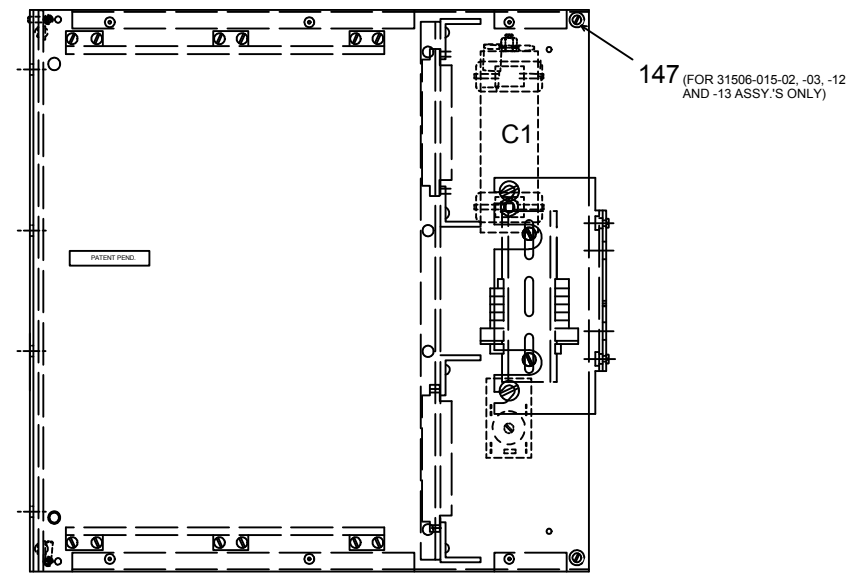

RIGHT VIEW  
FIG.2  
OTHERWISE SAME AS FIG.1

31038-249.AB3  
Rev. (AB)

Figure 3-3. System Module, P/N 31038-249-00 (Sheet 3 of 4)

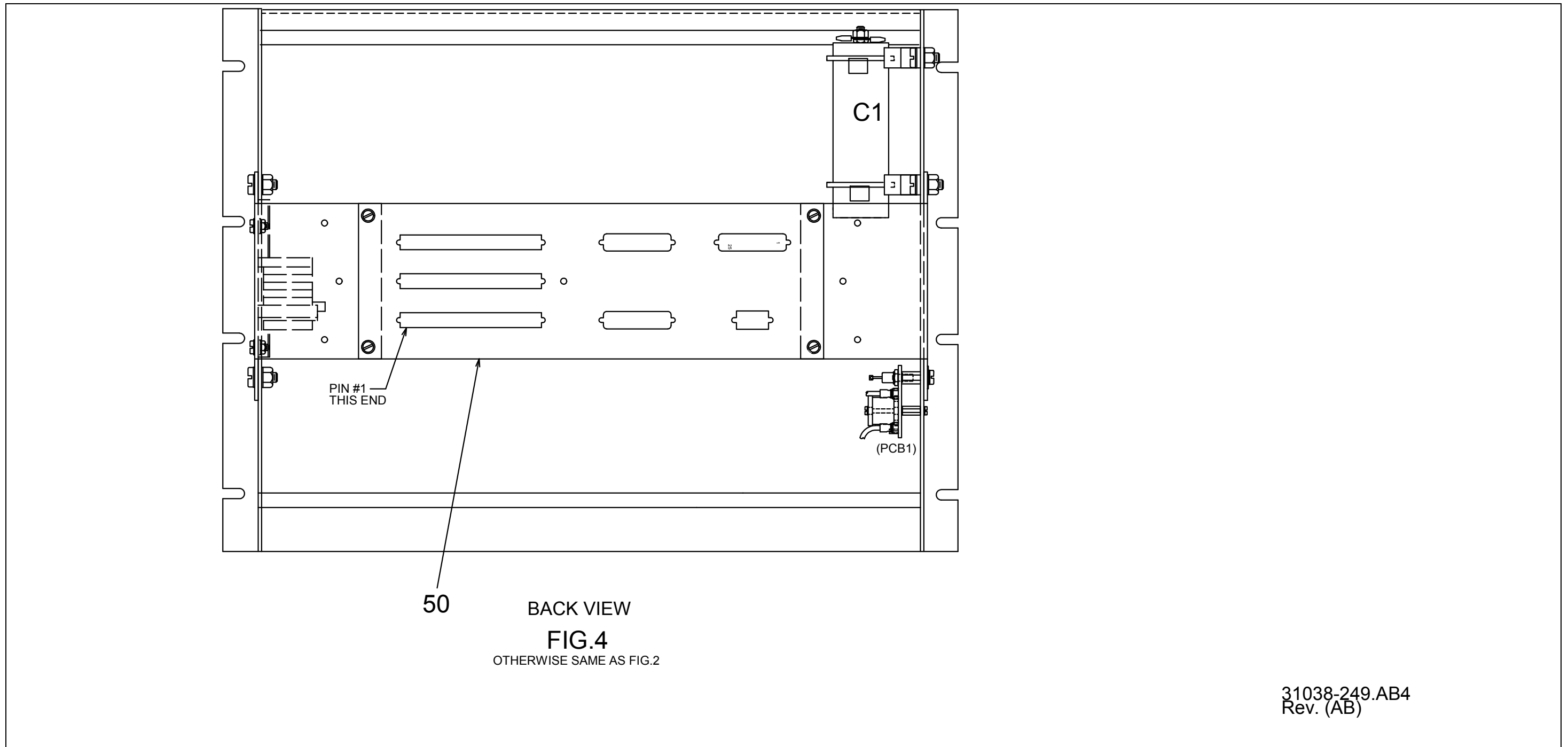

Figure 3-3. System Module, P/N 31038-249-00 (Sheet 4 of 4)

Table 3–1. System Module Parts List, P/N 31038-249-XX

Ref.	Description	Qty.	Part Number
1	Plate, Side	2	41885-223-00
2	Angle, Receptacle Mtg.	4	55696-062-00
3	Angle, Mtg	2	55696-061-00
4	Guide Mtg	6	01096-064-ON
6	Board Assembly, Mother	1	59473-743-01
10	Screw, .138-32 x .50 Lg Self Tapping	24	07606-016-ON
11	Washer, .112 ID, .270 OD, .019 Thk Lock	1	53029-066-00
12	Screw, .112-40 x .31 Lg Pan Hd	1	03604-010-ON
13	Rivet, .125 x .23 Pop	8	34496-031-00
14	Cover, Rear	1	50253-353-00
15	Hinge, Pull-Pin Release (Right)	2	53666-017-00
16	Hinge, Pull-Pin Release (Left)	2	53666-016-00
17	Guide, Card	42	01096-063-ON
18	Capacitor, 2600 $\mu$ F/50V	1	58281-370-00
19	Cable Mount, Nylon	2	00641-074-00
20	Terminal, .190 Ring, #16-14 Wire	4	59825-059-00
21	Screw, .190-32 x .31 Lg Pan Hd	3	03610-110-ON
22	Washer, .190 ID, .381 OD, .025 Thk Lock	3	53029-069-00
23	Terminal, .250 Faston, #18-14 Wire	8	59825-078-00
24	Receptacle, 14-Way "M" (SEE AD61-41)	1	58920-113-00
25	Terminal, Pin #14 Wire (SEE AD061-41)	4	00997-012-ON
26	Stud, Male (SEE AD061-41)	1	08885-171-00
27	Stud, Female	1	08885-172-00
28	Nut, .250-20, .19 Thk Hex	2	01272-008-ON
29	Washer, .250 ID, .478 OD, .028 Thk Lock	2	53029-075-00
30	Screw, .250-20 x .50 Lg Pan Hd	2	03615-016-ON
31	Washer, .266 ID, .500 OD, .031 Thk Flat	2	01250-011-ON
32	Strip, Marker	1	57617-121-00

Table 3–1. System Module Parts List, P/N 31038-249-XX (Cont.)

Ref.	Description	Qty.	Part Number
33	Plate, Name	1	00401-765-00
34	Tie, Cable 7.5 Lg	4	01232-001-ON
35	Tie, Cable 3.9 Lg	10	01232-000-ON
36	Washer, .156 ID, .312 OD, .032 Thk Flat	24	01250-004-ON
37	Rivet, .125 x .357 Pop	18	34496-032-00
40	Board Assembly, 5V Filter	1	59473-819-01
41	Terminal, #18-14 Wire, .250 Faston	4	59825-137-00
46	Washer, .190 ID, .562 OD, .040 Thk Flat	1	01250-010-ON
	Cable, #14 Tw Pr (Per 82A0006)	6.00	65156-175-01
	Circuit	---	40185-501-00
66	Case Comp (W/Rear Panel W/ split backplane)	1	31506-015-01
66	Case Comp (W/Rear Panel, W/O Rear Cover W/ split backplane)	1	31506-015-02
66	Case Comp (W/O Rear Panel, W/O Rear Cover W/ split backplane)	1	31506-015-03
75	Plate, Name	1	00401-765-00
76	Label (Pat. Pend.)	1	37947-032-00
146	Screw, .112-40 x .50 Lg Hex w/Serrated Washer	8	53141-021-00
147	Rod, Cable Support	2	59712-007-00
163	Washer, .112 ID, .270 OD, .019 Thk Lock	4	53029-066-00
164	Screw, .112-40 x .313 Lg Pan Hd	4	03604-010-ON
165	Nut, .112-40 x .11 Thk Keps	8	18466-002-00
	Arrangement Plan		59591-827-00
	Tubing, .500 Shrink Blk (Per 82P0004)	3	81411-001-01
<b>THE FOLLOWING PARTS ARE TO BE SPECIFIED AS REQUIRED</b>			
	Wire, #26 Solid Tefzel(Per 82A0006)	20	80559-068-01
	Jumper, Daisy Chain Type	50	01196-023-ON
77	Cover, Top/Bottom		50253-354-00
78	Rivet, .125 x .294 Pop (6 Per Ref. 77)		34496-054-00
79	Cover Comp. (Plastic)		58605-043-01

Table 3–1. System Module Parts List, P/N 31038-249-XX (Cont.)

Ref.	Description	Qty.	Part Number
80	Cover Comp. (Aluminum)		58605-043-02
86	Board Assembly, Non-Vital (Output)		59473-785-01 or-02
87	Board Assembly, Non-Vital (Input)		59473-757-02 or-03
60	Cable Comp, Row A ( Back Cover)		38216-393-01
61	Cable Comp, Row B ( Back Cover )		38216-393-02
62	Cable Comp, Row C (Back Cover )		38216-393-03
(1 REF. 60, 61, 62 IS REQUIRED FOR EACH REF. 86, 87, OR 169)			
70	Board Assembly, CSEX3		31166-175-KN
71	Cable Comp., Row C		38216-392-02
72	Cable Comp., Row B (Back Cover)		38216-392-04
73	Cable Comp., Row A (Back Cover)		38216-392-06
(1 REF. 71, 72, OR 73 IS REQUIRED FOR EACH REF. 70 AND FOR EACH REF. 74)			
74	Board Assembly, VSC (No. Spec By AE Dept)		59473-938 KN
82	Board Assembly, VRD		
83	Cable Comp., Row A(Back Cover)		
84	Cable Comp., Row B (Back Cover)		
85	Cable Comp., Row C		
(1 REF. 83, 84, OR 85 IS REQUIRED FOR EACH REF. 82)			
94	Receptacle, 60-Way		58920-252-00
(REF. 99 IS COMPRISED OF 59473-742-01 AND 40025-XXX-01 AND 40025-XXX-02 SYSTEM SOFTWARE)			
99	Board Assembly, CPU II		31166-374-01 or -02
100	Board Assembly, I/O Bus		59473-827-01
169	Board Assembly, Non-Vital (AC Out)		59473-936-01
101	Cable Comp. (Main Buss Cable) (No. Spec. By AE Dept) (-01 = 6 Pos., -02 = 5 Pos.) (1 Ref. 101 Req'd for each Ref. 99)		38216-395 KN
102	Cable Comp. (CPU-CPU Cable) (1 Ref. 102 Req'd for 2 Ref. 99)		38216-395-03

Table 3–1. System Module Parts List, P/N 31038-249-XX (Cont.)

Ref.	Description	Qty.	Part Number
114	Board Assembly Vital Input (No. Spec. By AE Dept) (-01 - Filtered, -02 - Standard, -03- Rectified)		59473-867 KN
115	Cable Comp., Input (1/2 Per Ref. 114)		38216-394-02
123	Board Assembly, SBO (No. Spec by A.E. Dept.)		59473-739 KN
124	Board Assembly, DBO (No. Spec by A.E. Dept.)		59473-747 KN
125	Board Assembly, LDO (No. Spec by A.E. Dept.)		59473-749 KN
127	Board Assembly, ACO		59473-937 KN
126	Cable Comp., Output (1/3 Per Each Ref.123 or 124 or 125 or 127)		38216-394-01
134	Board Assembly, Timer (No. Spec. By A.E. Dept)		59473-894 KN
139	Receptacle, Dual 18 (1 Per Ref. 134 Bd. Edge Row C)		58920-342-00
140	Retainer (12 Per Ref. 134)		18058-008-00
142	Cable Comp. (MB JPR Slot 5/6) [RESTRICTED USE] (If slots 5 & 6 need to be connected, use 31506-015-11, -12, -13 which contain continuous backplane)		38216-402-01
143	Plug, Keying (Per AD047-11)(2 or 3 Per Bd. Assy)		01097-027-ON
144	Cover (Coupler Holes, Rear Cover)		56029-088-00
145	Ring, (2 Per Each Ref. 144)		05713-083-00
148	Cover (Expansion Buss Receptacle)		56029-089-00
149	Screw, .112-40 x .44 Lg Pan Hd		03604-014-ON
161	Receptacle, Keying Header (2 Per Ref. .142)		58920-339-00
162	Retainer, (4 Per Ref. 142)		18058-013-00
63	Screw, .112-40 x .63 Lg Pan Hd (4 Per PC Board Slot)		03604-020-ON
64	Washer, .112 ID, .250 OD, .025 Thk Flat		01250-002-ON
65	Nut, .112-40 x .11 Thk Keps. (Plus 2 Per Ref. 149) (4 Per PC Board Slot)		18466-002-00
67	Shell		59367-010-00

Table 3–1. System Module Parts List, P/N 31038-249-XX (Cont.)

Ref.	Description	Qty.	Part Number
68	Stud, Male Per A.E. Dept. Arrangement Plan See AD061-34		08885-171-00
69	Stud, Female Per A.E. Dept. Arrangement Plan See AD061-34		08885-172-00
154	Stud, Male Per A.E. Dept. Arrangement Plan See AD061-34		08885-196-00
155	Stud, Female Per A.E. Dept. Arrangement Plan See AD061-34		08885-197-00
81	Cable Expansion Buss, (No. Spec. By AE Dept) (-01- Single; -02 = Double) Flat Cable Module to Module		38216-404 KN
170	Screw, .164-32 x .38 Lg Pan Hd		03608-012-ON
171	Washer, .168 ID, .381 OD, .023 Thk Lock		53029-062-00
172	Nut, .164-32 x .13 Thk Hex		01272-005-ON
173	Strip, Terminal		29173-197-00
174	Tag, Marker		59539-648-00
175	Terminal Block		29407-075-00
176	Jumper		01196-014-ON
NOTE: FOR INTERCONNECTION OF MODULES USE CABLE 38216-403-01, FOR MODULE POWER SUPPLY SEE 42560-273-01 (SINGLE), -02 (DOUBLE)			
159	Signature Header, Board Assembly "Vital Input"(No. Spec. By Alstom) (-01 upwards for I/O Buss Boards Ref. 100; -16 downwards for Input Boards Ref. 114)		59473-871 KN
160	Signature Prom, Integrated Circuit. "Vital Output"(Nos. Spec. By Alstom)(-01 upward for each Output Board Ref. 123,124,125 and 127)		39780-003 KN
166	Shaft	As Req'd	47544-085-00
167	Seal (2 per Ref. 166)	As Req'd	35285-000-00

Table 3–1. System Module Parts List, P/N 31038-249-XX (Cont.)

Ref.	Description	Qty.	Part Number
SOME OR ALL OF THE FOLLOWING PARTS ARE REQUIRED TO COMPLETE CIRCUIT BOARD ASSEMBLIES ABOVE THE BASE (-01) LEVEL.			
THE FOLLOWING PARTS MAY BE REQUIRED PER EACH REF. 70 CSEX3 CIRCUIT BOARD ASSEMBLY.			
	Jumper, (17 per Ref 70)		01196-012-ON
	IC, Unprogrammed EPROM(27C128)(2 Per Ref 70)		01169-646-ON
	IC, Ram 32K x 8 (2 Per Ref 70)		01169-525-ON
	IC, Unprogrammed EPROM (27C512)(2 per Ref 70)		01169-563-ON
THE FOLLOWING MAY BE REQUIRED PER EACH REF. 74 VSC BOARD.			
	IC, EPROM (27C128)(2 Per Ref 74)		01169-646-ON
THE FOLLOWING MAY BE REQUIRED PER EACH REF. 99 CPU/PD BOARD.			
	IC, EPROM (27H010) (2 Per Ref 99)		01169-648-ON
THE FOLLOWING CABLES ARE REQUIRED WHEN PLATE ASSEMBLY (DIAGNOSTIC CONTROL PANEL) 42560-285-01 IS REQUIRED.			
	Row A		38216-452-01
	Row B Rear cover		38216-452-02
	Row C		38216-452-03
177	NVTWC MODEM (NON FSK)	1	31166-099-02
178	NVTWC MUX (NON FSK)	1	31166-100-01
179	NVI (6 volt)	1	31166-106-01
180	NVTWC MODEM (NON Manchester FSK)	1	31166-119-02
181	NVTWC MODEM (Manchester FSK)	1	31166-119-03
182	Cable Comp, Row A (Back Cover)	1	38216-497-01
183	Cable Comp, Row B (Back Cover)	1	38216-497-02
184	Cable Comp, Row C (Back Cover)	1	38216-497-03
1 REF. 182, 183, OR 184 IS REQUIRED FOR EACH REF. 171, 178, 179, 180, OR 181.			
66	Case Comp (W/Rear Panel W/ continuous backplane)	1	31506-015-11
66	Case Comp (W/Rear Panel, W/O Rear Cover W/ continuous backplane)	1	31506-015-12

Table 3–1. System Module Parts List, P/N 31038-249-XX (Cont.)

<b>Ref.</b>	<b>Description</b>	<b>Qty.</b>	<b>Part Number</b>
66	Case Comp (W/O Rear Panel, W/O Rear Cover W/ continuous backplane)	1	31506-015-13
66	Case Comp (W/ Rear Panel, W/O Rear Cover W/ split backplane)	1	31506-015-14
66	Case Comp (DEEP)(W/ Rear Cover, W/split backplane)	1	31506-015-15
66	Case Comp RTU (DEEP)(W/ Rear Cover, W/ Continuous backplane)	1	31506-015-16
WHEN EITHER 3156-015-15 OR 31506-015-16 IS REQUIRED, DELETE CABLE SUPPORT RODS 59712-007-00 (ITEM 7) AND TUBING 81411-001-01 (ITEM 12). ALSO, ADD THE FOLLOWING:			
77	Cover, Top/Bottom (DEEP)	2	50253-404-00
78	Rivet, .125 x .294 POP	16	34496-054-00

3.4. SYSTEM MODULE CIRCUIT

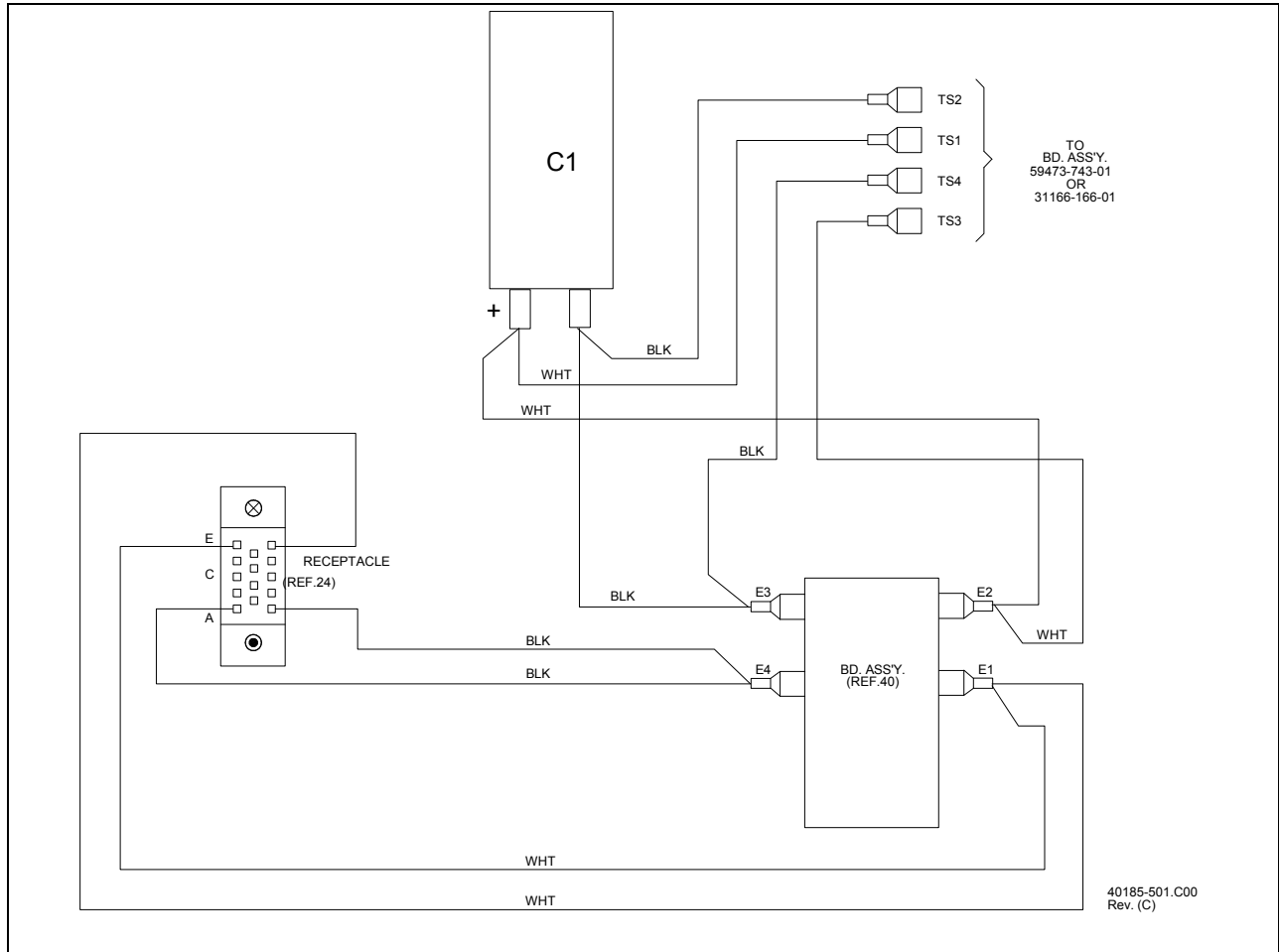

Figure 3-4. System Module Circuit

3.5. CABLE, MOTHERBOARD JUMPER, P/N 38216-402-01

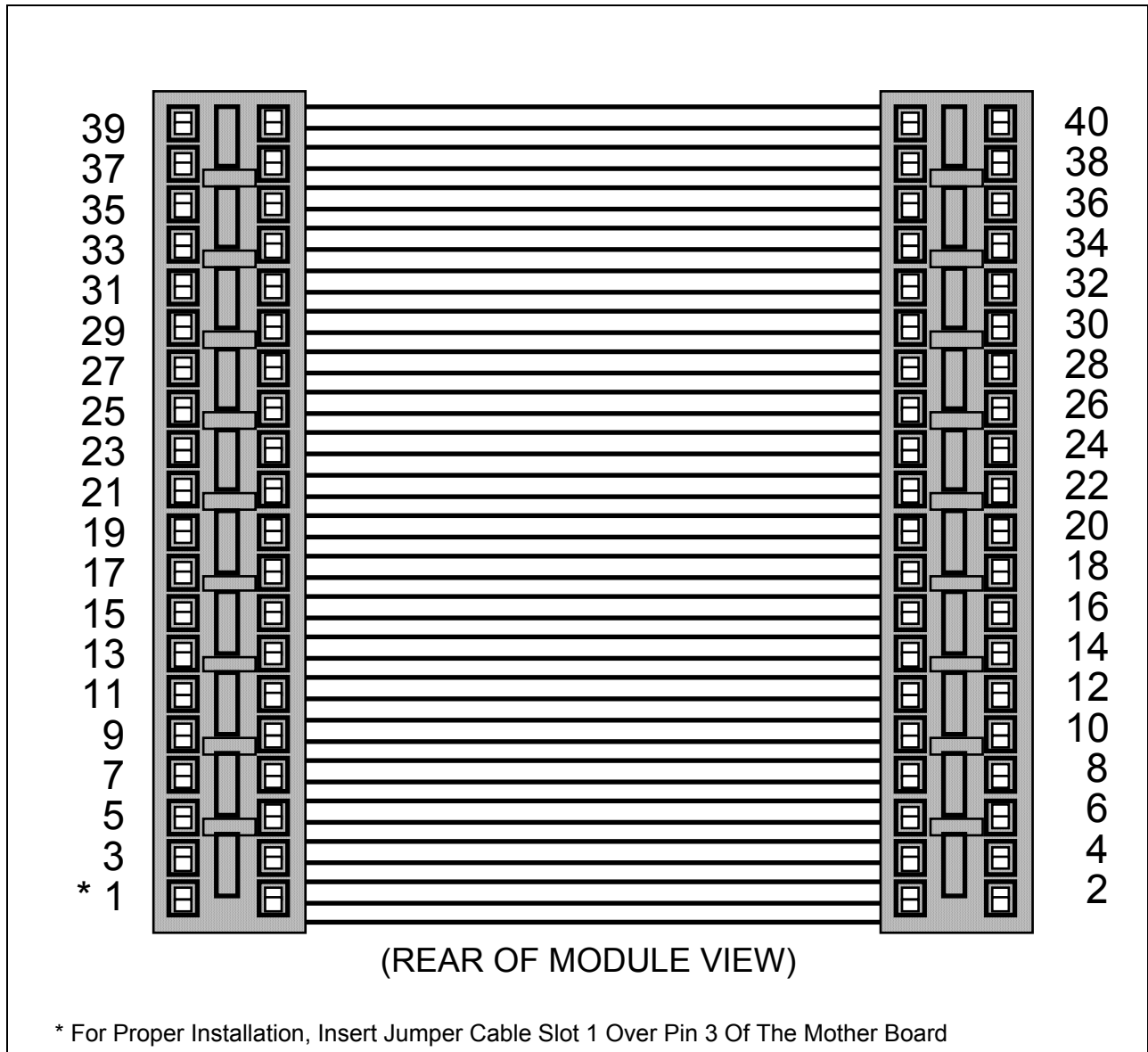
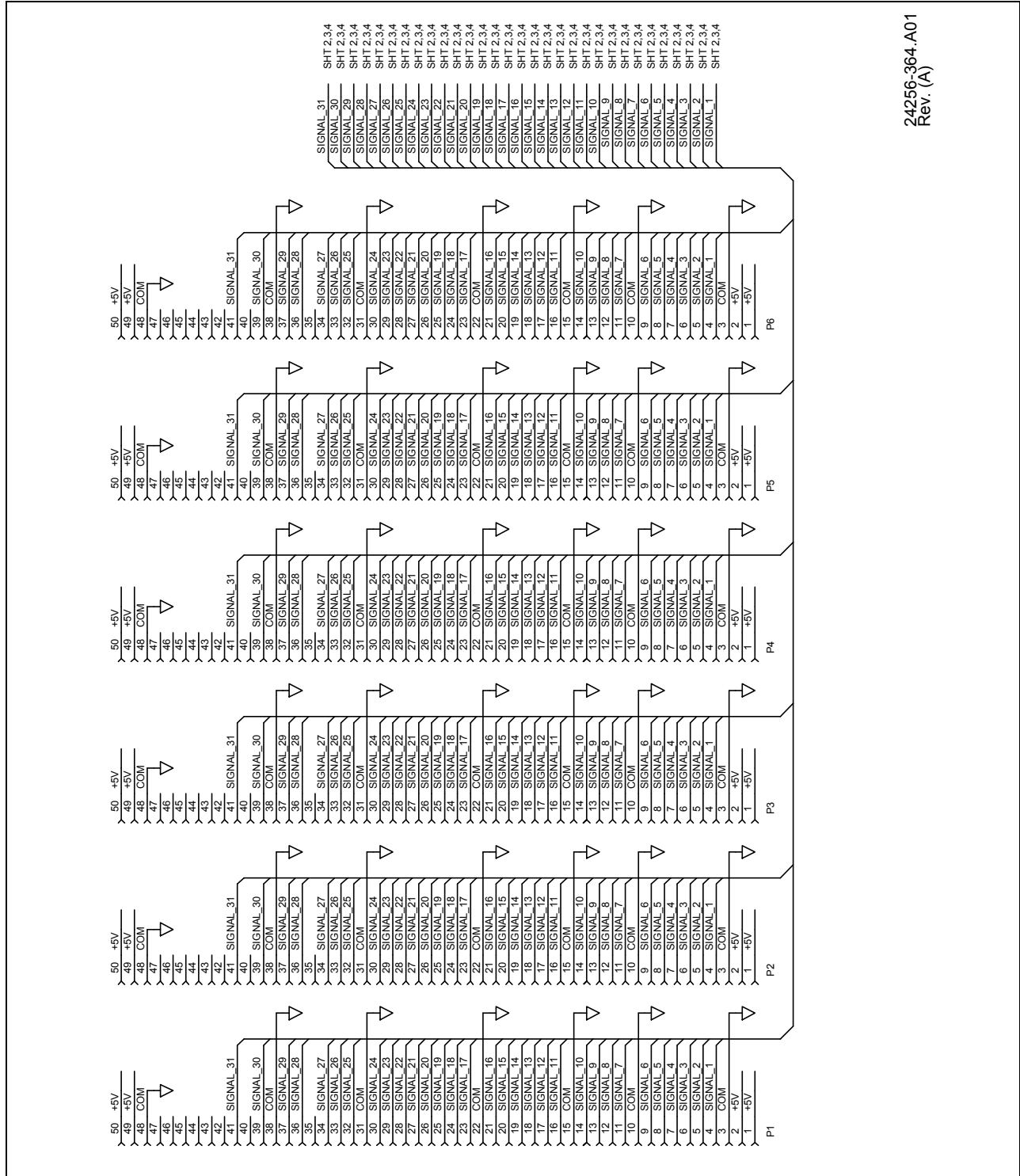

Figure 3–5. Cable, Motherboard Jumper, P/N 38216-402-01

3.6. MOTHERBOARD, CONTINUOUS BACKPLANE CIRCUIT, P/N 31166-166-01



24256-364-A01  
Rev. (A)

Figure 3–6. Motherboard, Continuous Backplane Circuit, P/N 31166-166-01 (Sheet 1 of 4)

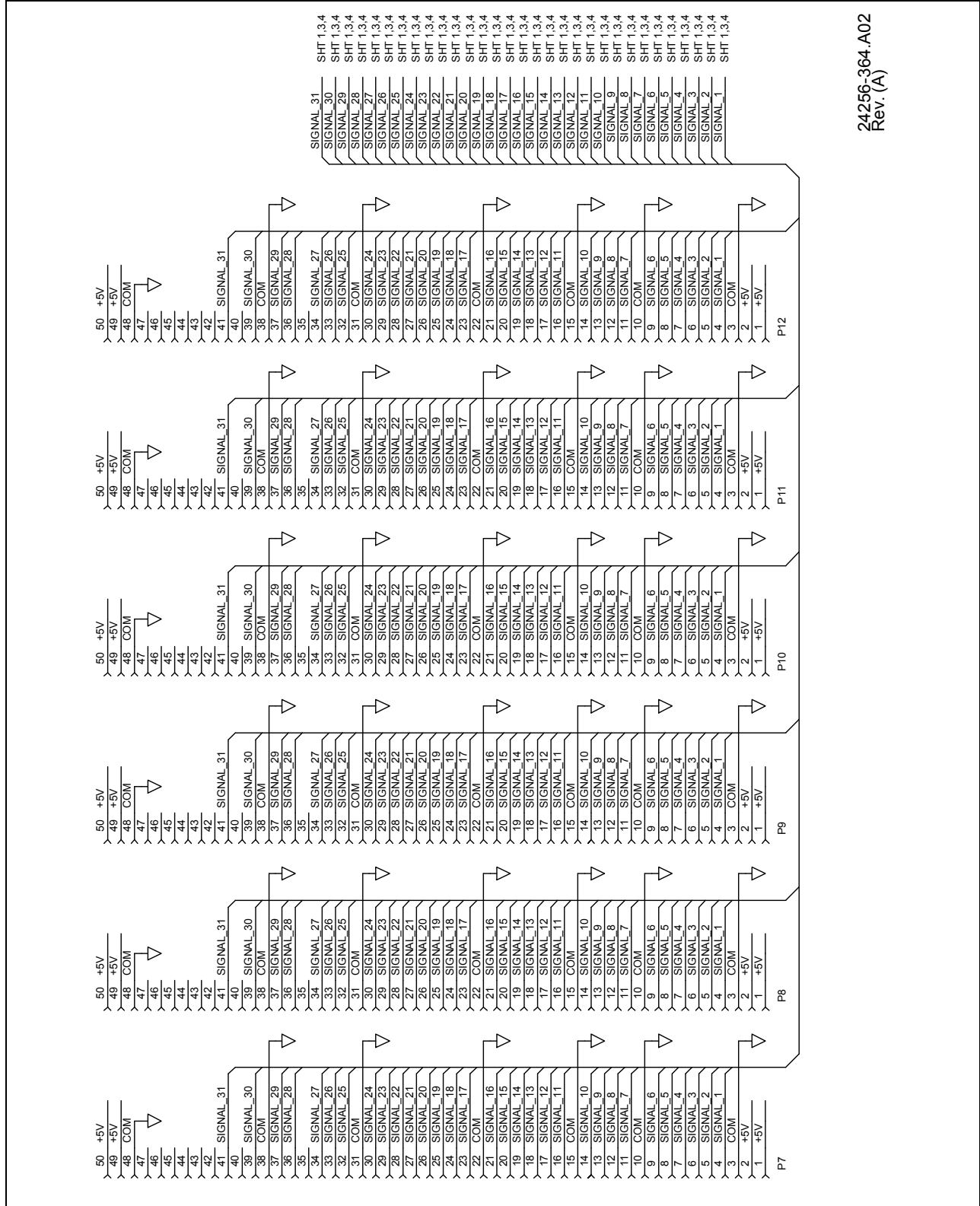

24256-364.A02  
Rev. (A)

Figure 3–6. Motherboard, Continuous Backplane Circuit, P/N 31166-166-01  
(Sheet 2 of 4)

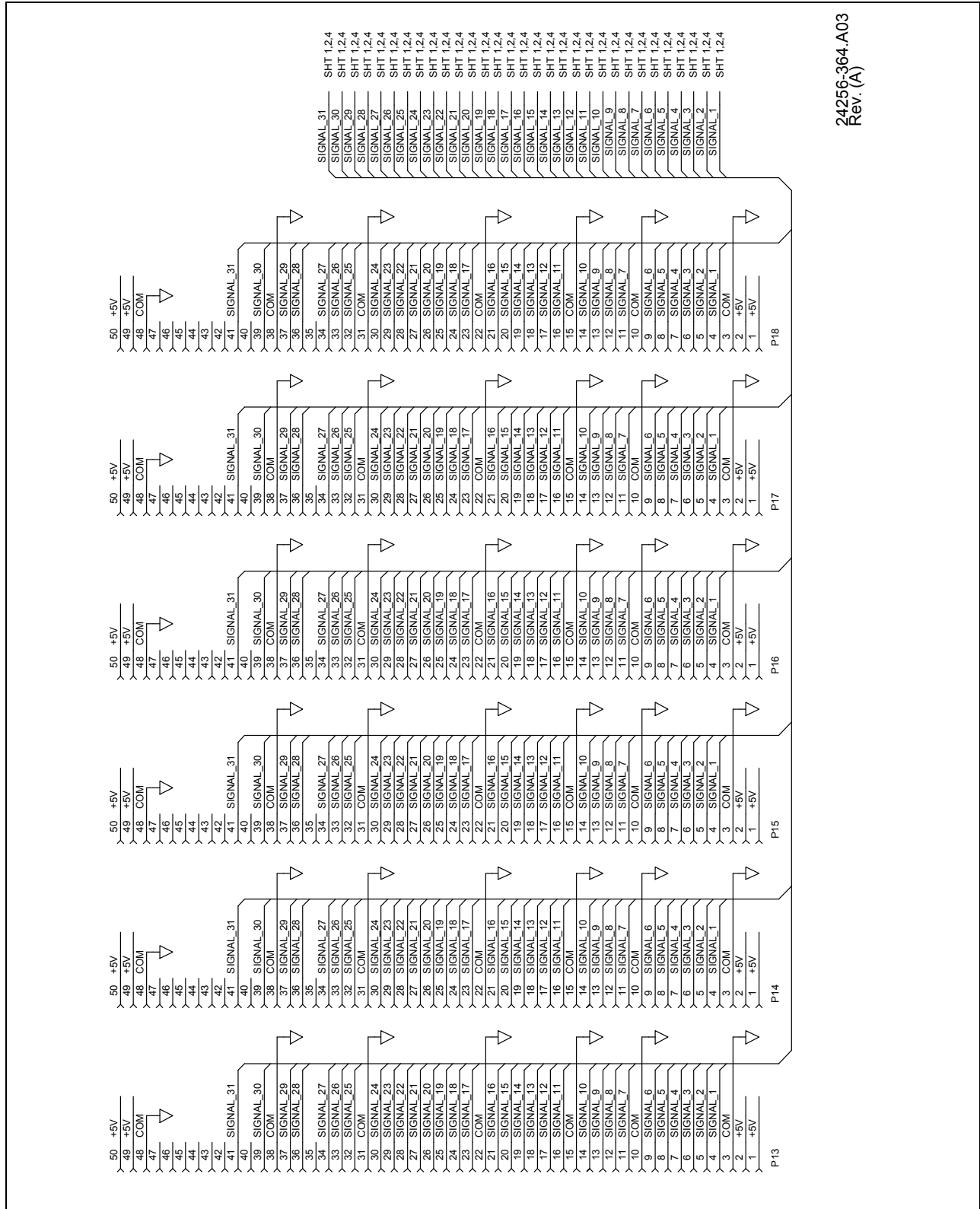

24256-364.A03  
Rev. (A)

Figure 3–6. Motherboard, Continuous Backplane Circuit, P/N 31166-166-01  
(Sheet 3 of 4)

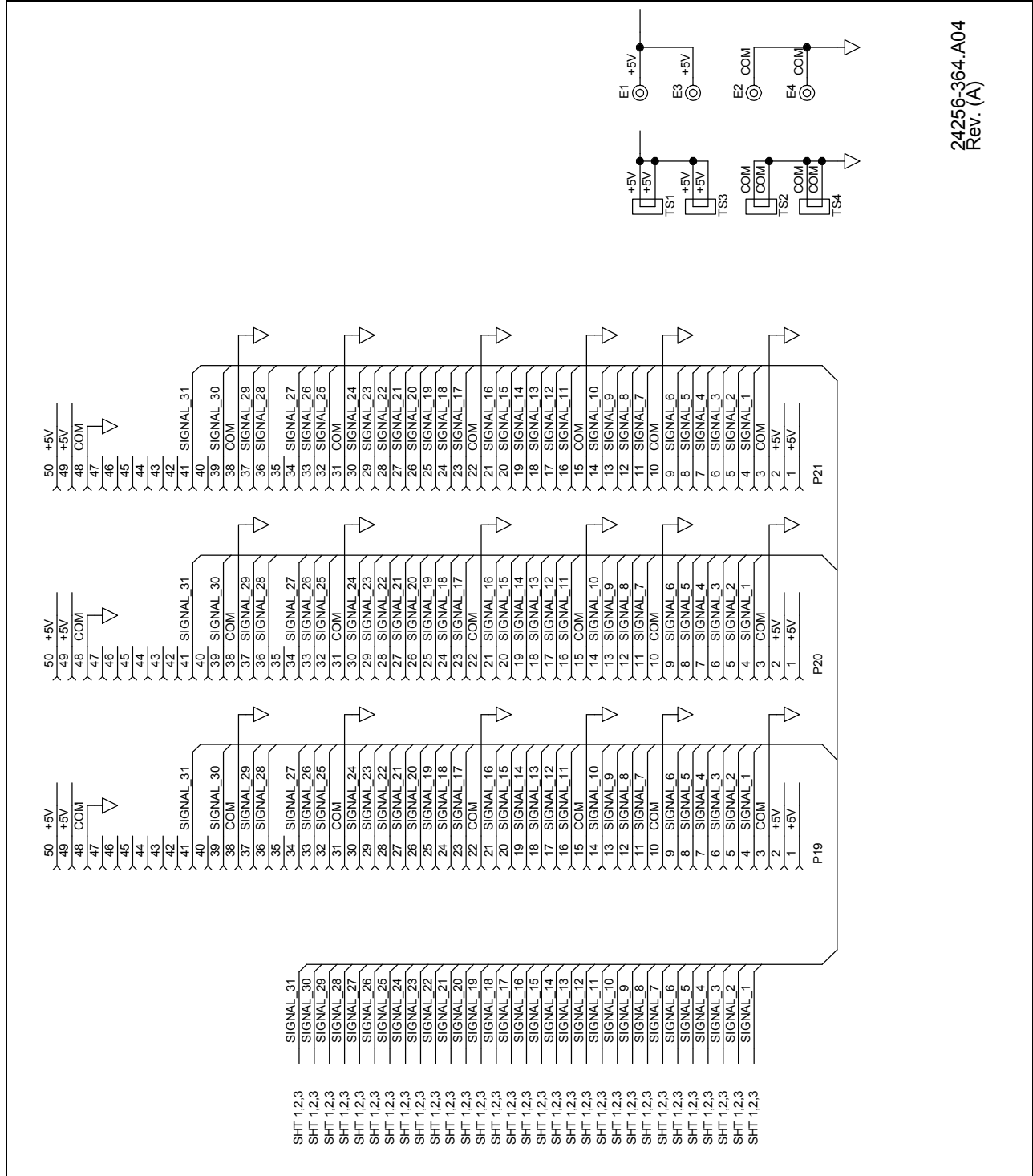

24256-364.A04  
Rev. (A)

Figure 3–6. Motherboard, Continuous Backplane Circuit, P/N 31166-166-01  
(Sheet 4 of 4)

THIS PAGE INTENTIONALLY LEFT BLANK.

3.7. MOTHERBOARD ASSEMBLY (B1), P/N 59473-743-01

NOTE 1:- ASSEMBLE AND INSPECT PER STD-109, EXCEPT FOR CONFORMAL COATING. DO NOT CONFORMAL COAT.  
 NOTE 2:- STAMP GROUP NUMBER WITH 1/8 INCH HIGH BLACK NUMERAL AS REQUIRED.  
 NOTE 3:- NO COMPONENT TO PROJECT HIGHER THAN 9/16 FROM BOARD.  
 NOTE 4:- MOUNT P1 THRU P21 ON COMPONENT SIDE.  
 NOTE 5:- MOUNT TS1 THRU TS4 ON SOLDER SIDE AS SHOWN.  
 NOTE 6:- SILKSCREEN IS TO APPEAR ON SOLDER SIDE.

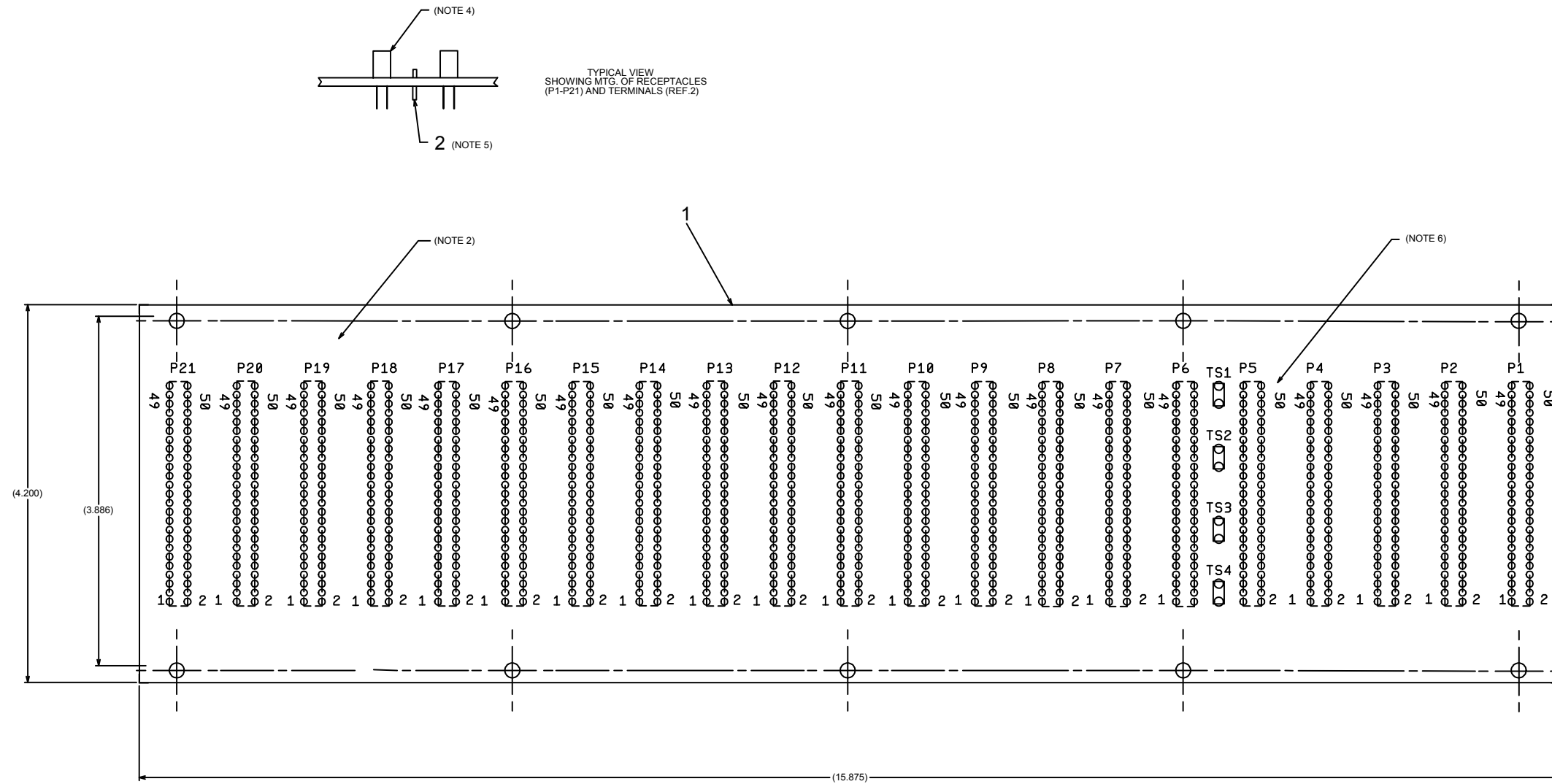

VIEW SHOWING SOLDER SIDE OF BOARD

59473-743.C00  
 Rev. (C)

Figure 3-7. Motherboard Assembly (B1), P/N 59473-743-01

Table 3–2. Motherboard Assembly (B1) Parts List, P/N 59473-743-01

<b>Ref.</b>	<b>Description</b>	<b>Qty.</b>	<b>Part Number</b>
1	Board (Printed)	1	
2	Terminal, Faston (TS1 - TS4)	4	
	Receptacle, 50-Way (P1 - P2)	21	

3.8. MAIN BUS BOARD ASSEMBLY, P/N 31166-201-07

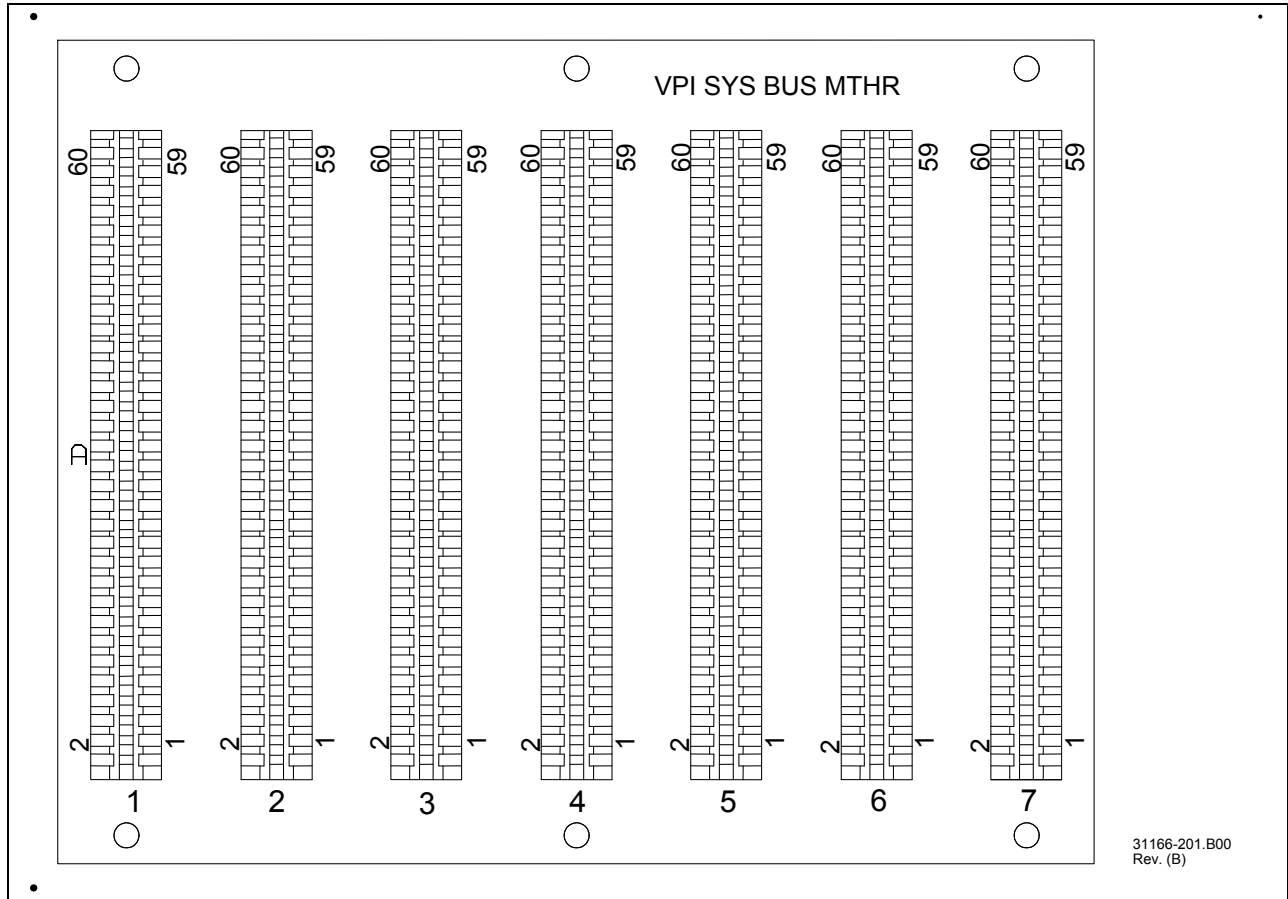

Figure 3–8. Main Bus Board Assembly, P/N 31166-201-07

3.9. VITAL AND NON-VITAL MOTHERBOARD INTERFACE CONNECTIONS

Table 3–3. Vital and Non-Vital Motherboard Interface Connections

<b>Pin No.</b>	<b>Description (Vital I/O)</b>	<b>Description (Non-Vital I/O)</b>
1	+5V	+5V
2	+5V	+5V
3	5V COM	5V COM
4	IODB0	NVDB0
5	IODB1	NVDB1
6	IODB2	NVDB2
7	IODB3	NVDB3
8	IODB4	NVDB4
9	IODB5	NVDB5
10	5V COM	5V COM
11	IODB6	NVDB6
12	IODB7	NVDB7
13	IODB8	EMSEL/
14	IODB9	NVA0
15	5V COM	5V COM
16	IODBA	NVA1
17	IODBB	NVA2
18	IODBC	NVA3
19	IODBD	NVA4
20	IODBE	NVA5
21	IODBF	NVA6
22	5V COM	5V COM
23	ENIORD/	NVIORD/
24	ENIOWR/	CLR.IREQ/
25	T-OUTC3	NVA7
26	TIMC4	NVA8
27	IOAB1	NVA9
28	IOAB2	NVA10
29	IOAB3	NVA11

Table 3–3. Vital and Non-Vital Motherboard Interface Connections (Cont.)

Pin No.	Description (Vital I/O)	Description (Non-Vital I/O)
30	IOAB4	NVA12
31	5V COM	5V COM
32	CLR/	NVA13
33	125 KHZ CLK	NVIOWR/
34	OUTC1/	POLL/
35	SEL DISABLE ON-OFF/ (See Note 1)	5V COM
36	DISABLE ON-OFF/	NVMRD/
37	IODT-R/	NVMWR/
38	5V COM	5V COM
39	RCHK CLK	INT/REQ/
40	SEL 1 (See Note 2)	Not Used
41	OUTC2/	PROG
42	SEL 2 (See Note 2)	MISC SEL 2
43	SEL 3 (See Note 2)	MISC SEL 3
44	ADD SEL 0 (See Note 3)	ADD SEL 0 (See Note 3)
45	ADD SEL 1 (See Note 3)	ADD SEL 1 (See Note 3)
46	ADD SEL 2 (See Note 3)	ADD SEL 2 (See Note 3)
47	ADD SEL 3 (See Note 3)	ADD SEL 3 (See Note 3)
48	5V COM	5V COM
49	+5V	+5V
50	+5V	+5V

**NOTE**

1. SEL DISABLE ON-OFF/ signal is wire wrapped to pin 36 when an output board requires pin 35 output current checking. This function is used with the lamp drive outputs to permit hot and cold filament tests.
2. SEL 1 is wire wrapped to SEL 2 to select the lower data bus. SEL 1 is wire wrapped to SEL 3 to select the upper data bus. This is only for the Vital output boards.
3. Pins are wire wrapped to 5V COM as required for the board address.

Table 3–4. Motherboard Power Supply Interface

<b>Power Supply Connections</b>	<b>Terminal Labels</b>	<b>Motherboard Pins Connected</b>
Filtered 5 Volt	TS1, TS3	1, 2, 49, 50
Common	TS2, TS4	3, 10, 15, 22, 31, 38, 48

Split and Continuous Backplanes - Split backplane terminals (TS1 through TS4) are located between slots 5 and 6. Continuous backplane terminals are located as follows: TS1 between slots 6 and 7, TS2 between slots 5 and 6, TS3 between slots 4 and 5, and TS4 between slots 3 and 4.

Grounding Considerations for all Chassis - The Filter Board (59473-819-01) is grounded to the chassis via its mounting hardware. The Motherboard (P/N 59473-743-01 or P/N 31166-166-01) is also grounded to the chassis via its mounting hardware. Each chassis is also grounded to the rack shelf. The rack is then connected to earth ground.

3.10. FILTER BOARD, 5V, P/N 59473-819-01

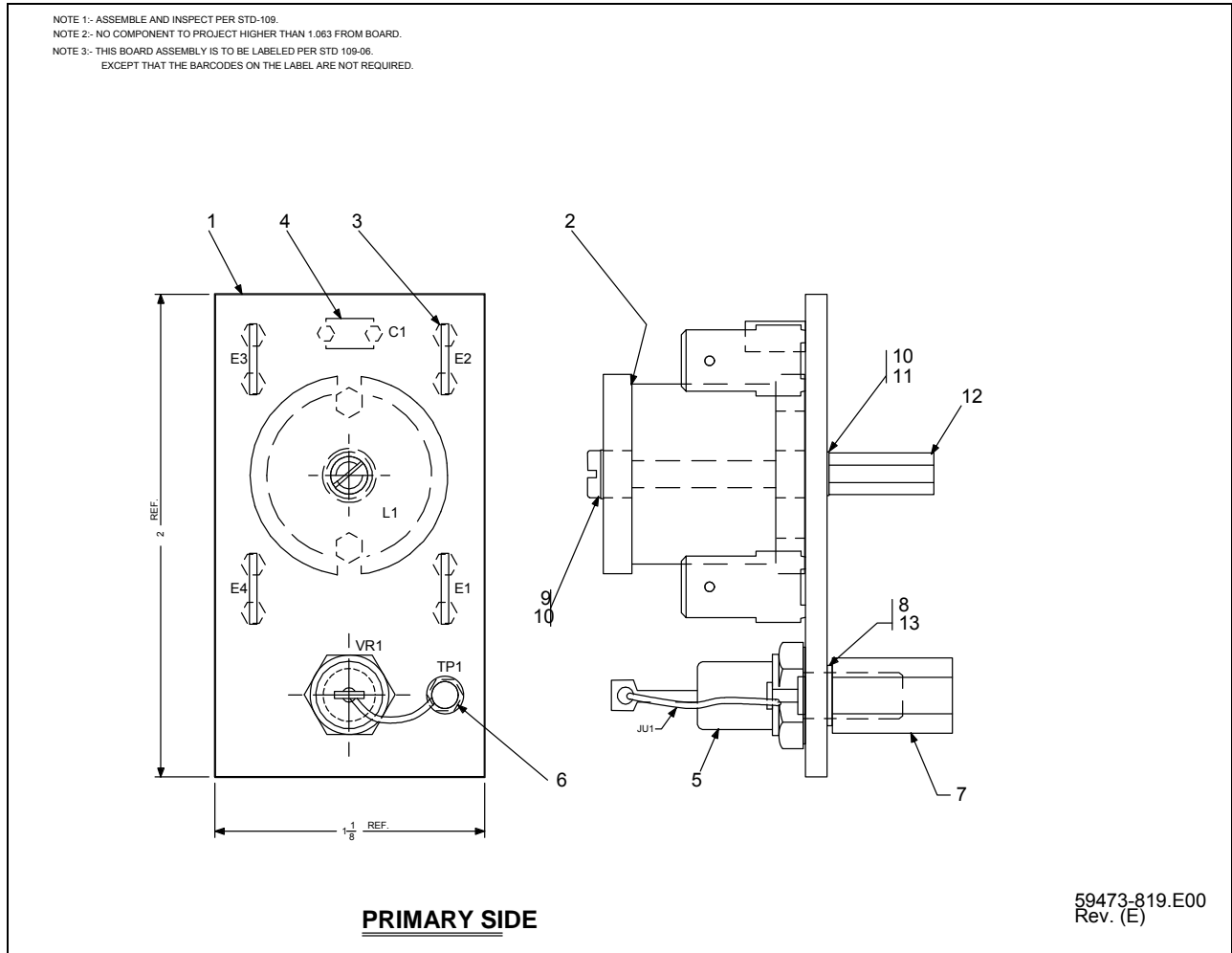

Figure 3-9. Filter Board, 5V, P/N 59473-819-01

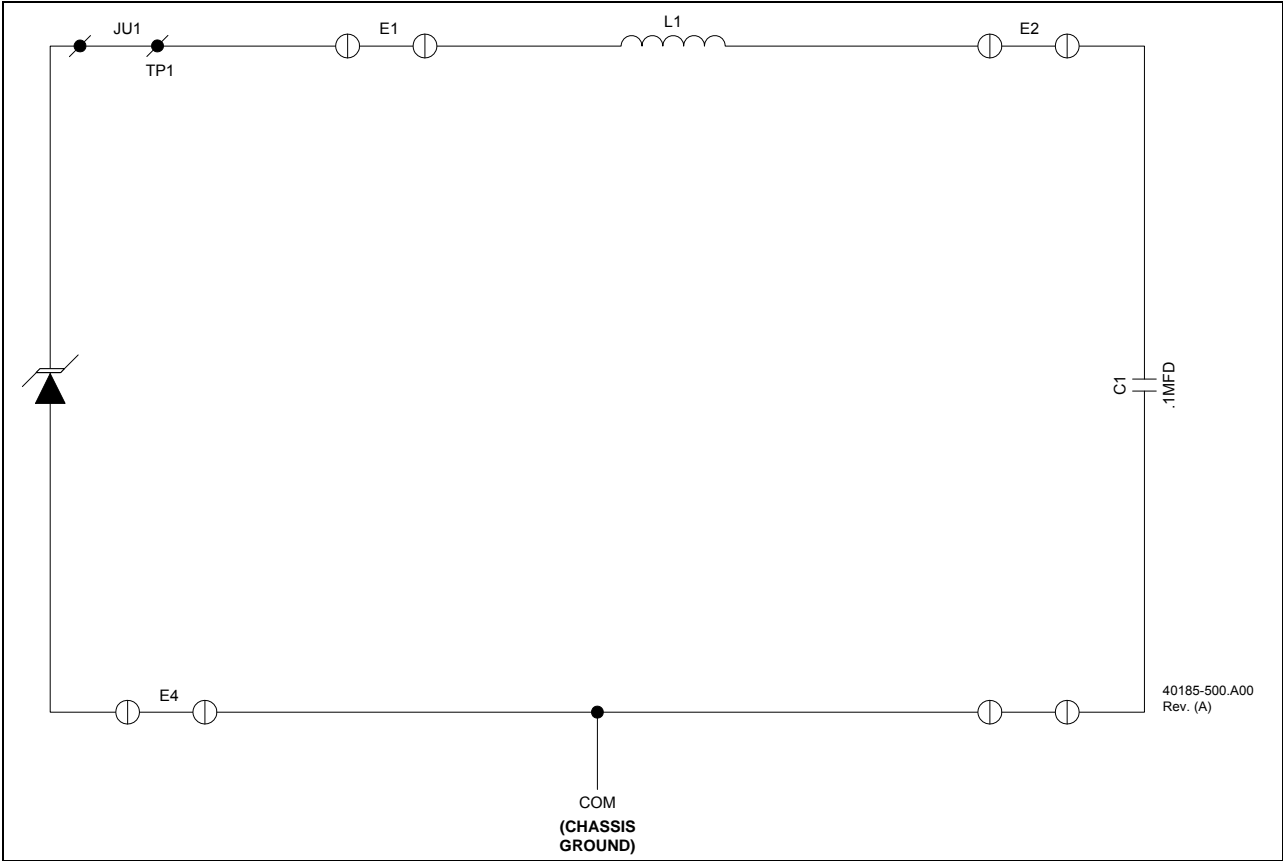

Figure 3-10. Circuit, Filter Board, 5V, P/N 59473-819-01

3.11. CABLE, BOARD EDGE CONNECTOR, P/N 38216-392-01 THRU -06

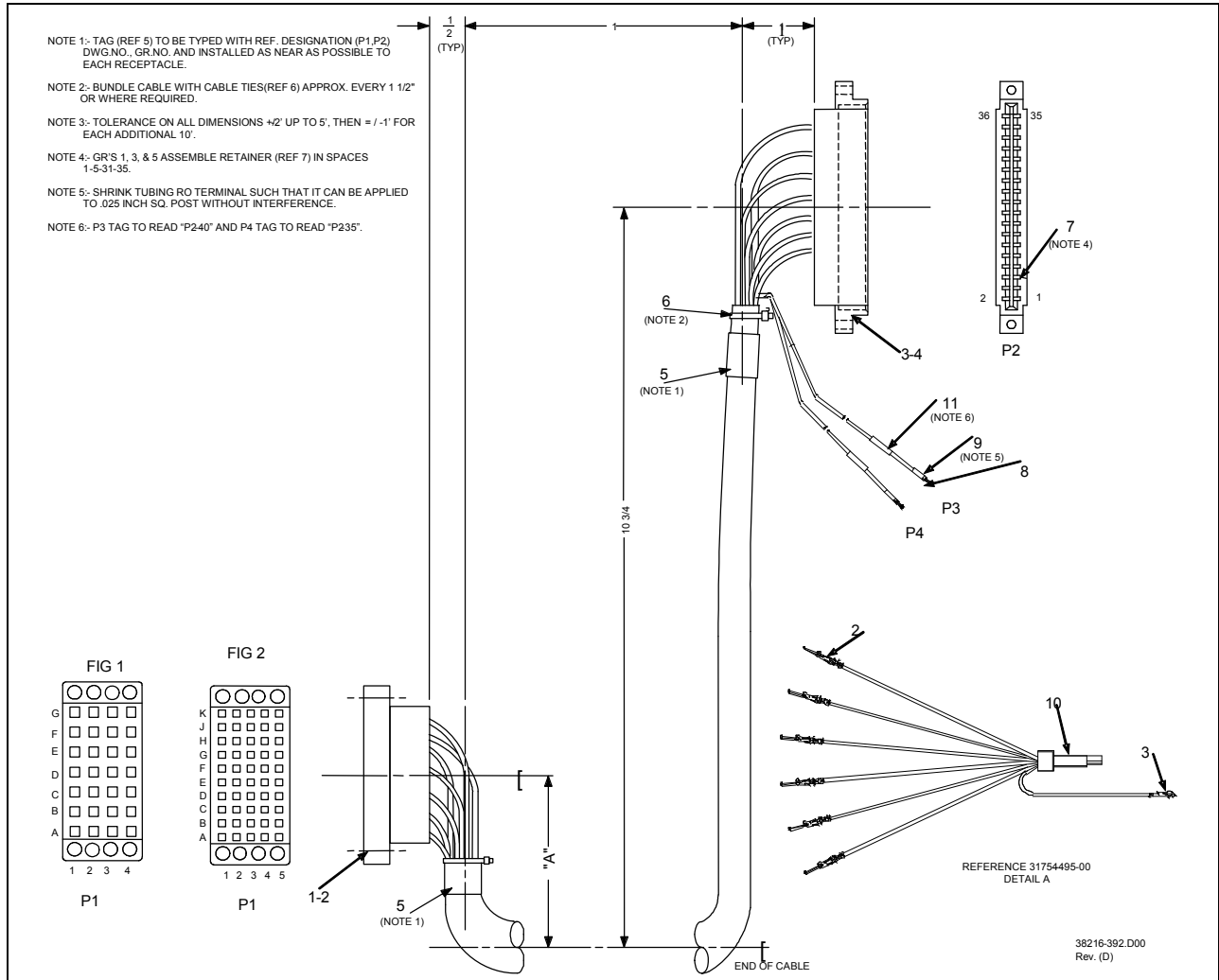

Figure 3–11. Cable, Board Edge Connector, P/N 38216-392-01 thru -06

FROM	WIRE	TO	FROM	WIRE	TO
P1- C1	_____	1	P1- F4	_____	22
B5	_____	2	C4	_____	23
C3	_____	3	F5	_____	24
D1	_____	4	A2	_____	25
C5	_____	5	G1	_____	26
D3	_____	6	A3	_____	27
D2	_____	7	G2	_____	28
D5	_____	8	A5	_____	29
E5	_____	9	G3	_____	30
E2	_____	10	B1	_____	31
E1	_____	11	G4	_____	32
E3	_____	12	B3	_____	33
A1	_____	13	G5	_____	34
E4	_____	14	B4	_____	35
D4	_____	15	H1	_____	36
F1	_____	16			
C2	_____	17			
F2	_____	18			
A4	_____	19			
F3	_____	20			
B2	_____	21			

31574-322.C00  
Rev. (C)

Figure 3–12. Wire Tables for Cables, P/N 38216-392-01 thru -06

3.12. CABLE, NON-VITAL I/O, P/N 38216-393-01 THRU -03

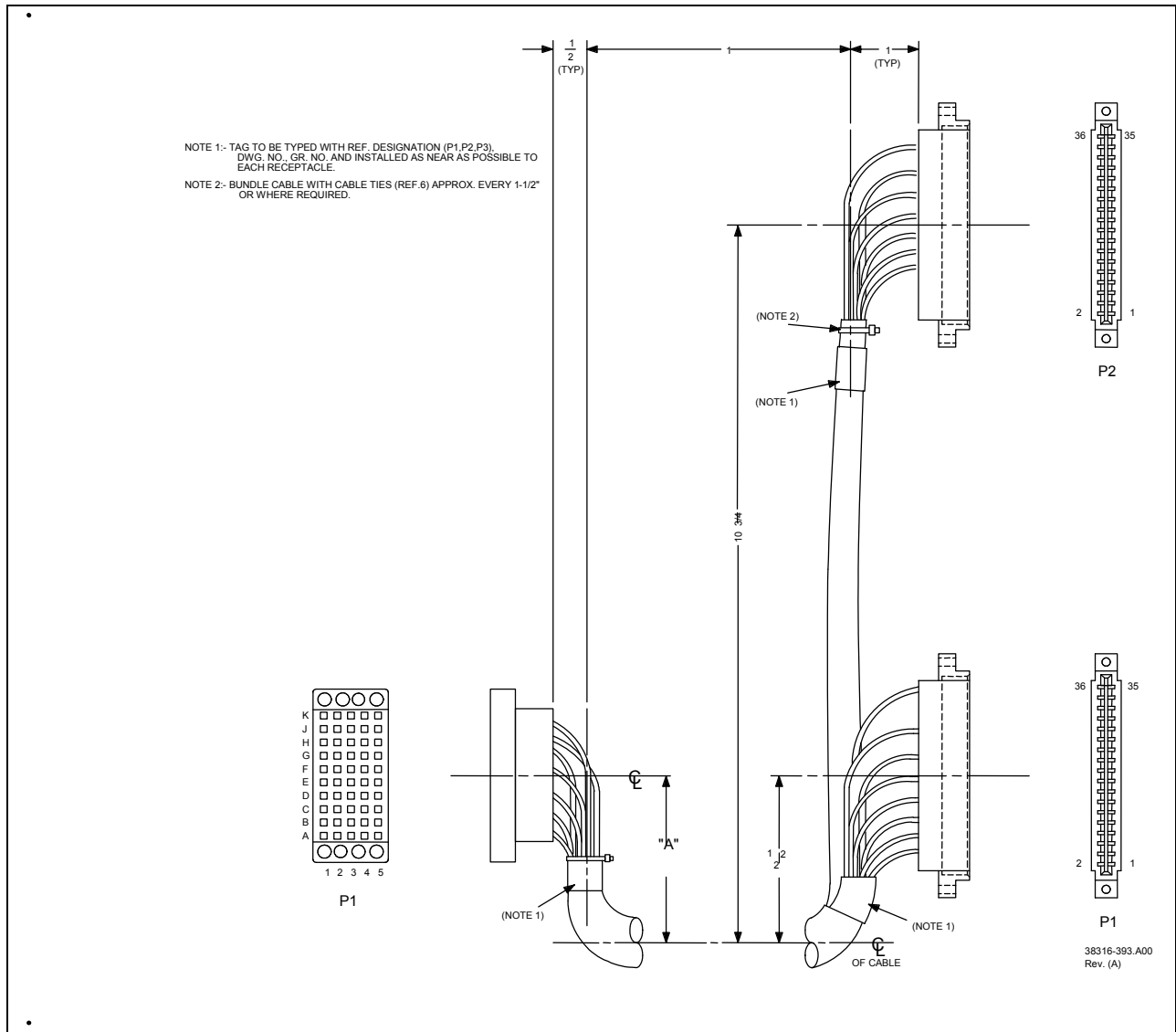

Figure 3-13. Cable, Non-Vital I/O, P/N 38216-393-01 thru -03

Modules and Cables

FROM	WIRE	TO	FROM	WIRE	TO
P1- K1	_____	34	P1- K3	_____	34
J1	_____	32	J3	_____	32
H1	_____	30	H3	_____	30
G1	_____	29	G3	_____	29
F1	_____	26	F3	_____	26
E1	_____	25	E3	_____	25
D1	_____	22	D3	_____	22
C1	_____	21	C3	_____	21
A1	_____	35	A3	_____	35
B1	_____	36	B3	_____	36
K2	_____	18	K4	_____	18
J2	_____	17	J4	_____	17
H2	_____	14	H4	_____	14
G2	_____	13	G4	_____	13
F2	_____	10	F4	_____	10
E2	_____	9	E4	_____	9
D2	_____	6	D4	_____	6
C2	_____	5	C4	_____	5
A2	_____	19	A4	_____	19
B2	_____	20	B4	_____	20

31574-319.B00  
Rev. (B)

Figure 3–14. Wire Tables for Cables, P/N 38216-393-01, -02 and -03

3.13. CABLE, VITAL I/O, P/N 38216-394-01 THRU -03

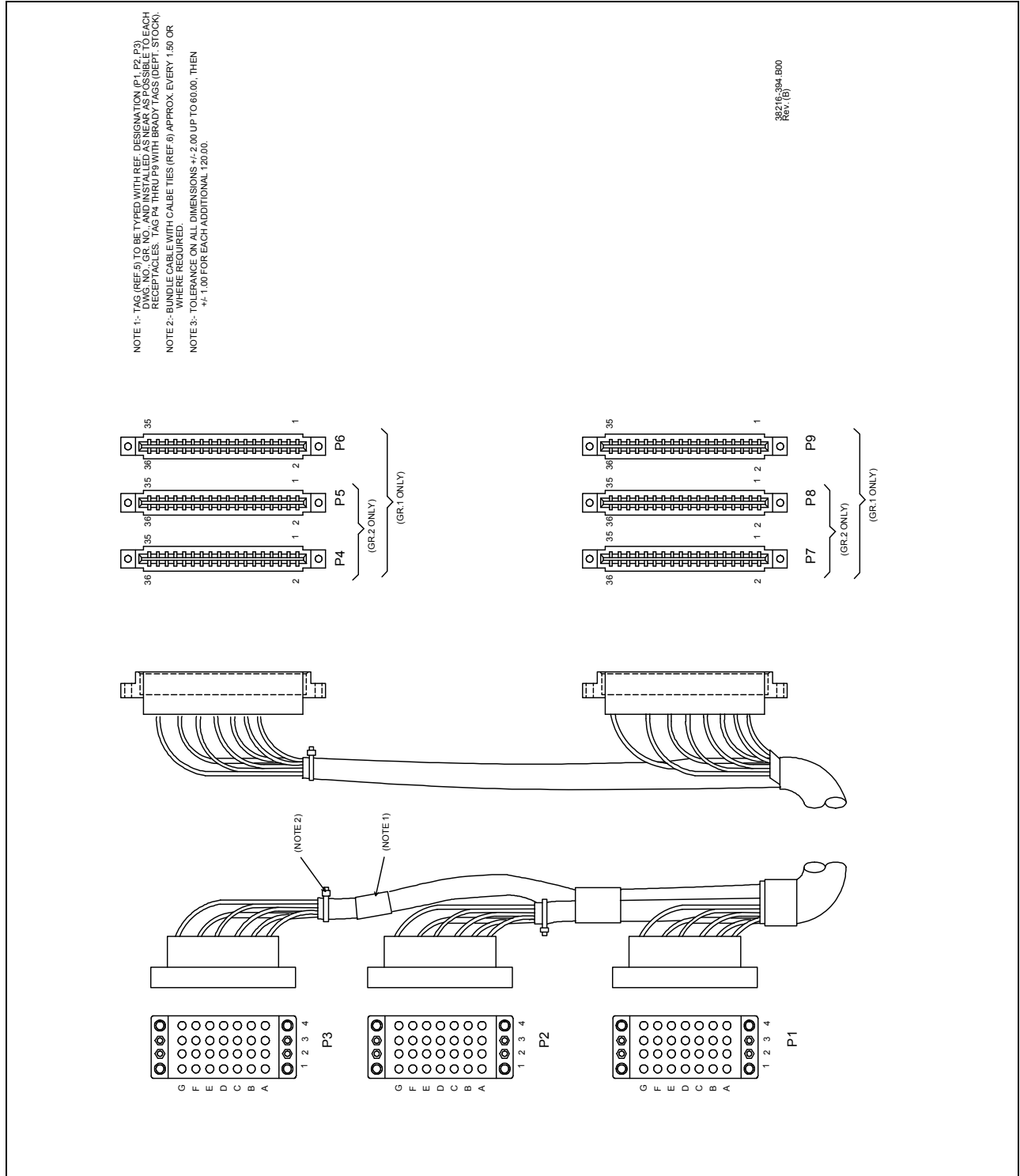

Figure 3-15. Cable, Vital I/O, P/N 38216-394-01 thru -03

## Modules and Cables

FROM	WIRE	TO	FROM	WIRE	TO	FROM	WIRE	TO	FROM	WIRE	TO
P4-34	_____	G1	P6-34	_____	G3	P7-34	_____	D1	P9-34	_____	D4
		P3-			P3-			P2-			P2-
33	_____	G2	33	_____	G4	33	_____	C1	33	_____	C4
26	_____	F1	26	_____	F4	26	_____	B1	26	_____	B4
25	_____	E1	25	_____	E4	25	_____	A1	25	_____	A4
22	_____	D1	22	_____	D4	22	_____	G1	22	_____	G4
21	_____	C1	21	_____	C4	21	_____	F1	21	_____	F4
10	_____	B1	10	_____	B4	10	_____	E1	10	_____	E4
9	_____	A1	9	_____	A4	9	_____	D1	9	_____	D4
2	_____	G1	2	_____	G4	2	_____	C1	2	_____	C4
1	_____	F1	1	_____	F4	1	_____	B1	1	_____	B4
P5-34	_____	F2				P8-34	_____	D2			
		P3-						P2-			
33	_____	F3				33	_____	D3			
26	_____	E2				26	_____	B2			
25	_____	E3				25	_____	B3			
22	_____	D2				22	_____	F2			P1-
21	_____	D3				21	_____	F3			
10	_____	C2				10	_____	D2			
9	_____	C3				9	_____	D3			
2	_____	F2				2	_____	B2			
1	_____	F3				1	_____	B3			
		P2-									

31574-320.B00  
Rev. (B)

Figure 3–16. Wire Tables for Cable, P/N 38216-394-01

## Modules and Cables

FROM	WIRE	TO	FROM	WIRE	TO	FROM	WIRE	TO	FROM	WIRE	TO
P7- 2	_____	A1	P4- 2	_____	C1	P8- 2	_____	A3	P5- 2	_____	C3
1	_____	A2	1	_____	C2	1	_____	A4	1	_____	C4
6	_____	B1	6	_____	D1	6	_____	B3	6	_____	D3
5	_____	B2	5	_____	D2	5	_____	B4	5	_____	D4
10	_____	C1	10	_____	E1	10	_____	C3	10	_____	E3
9	_____	C2	9	_____	E2	9	_____	C4	9	_____	E4
14	_____	D1	14	_____	A1	14	_____	D3	14	_____	A3
13	_____	D2	13	_____	A2	13	_____	D4	13	_____	A4
18	_____	E1	18	_____	B1	18	_____	E3	18	_____	B3
17	_____	E2	17	_____	B2	17	_____	E4	17	_____	B4
22	_____	F1	22	_____	C1	22	_____	F3	22	_____	C3
21	_____	F2	21	_____	C2	21	_____	F4	21	_____	C4
26	_____	A1	26	_____	D1	26	_____	A3	26	_____	D3
25	_____	A2	25	_____	D2	25	_____	A4	25	_____	D4
30	_____	B1	30	_____	E1	30	_____	B3	30	_____	E3
29	_____	B2	29	_____	E2	29	_____	B4	29	_____	E4

31574-321.C00  
Rev. (C)

Figure 3–17. Wire Tables for Cable, P/N 38216-394-02

FROM	WIRE	TO	FROM	WIRE	TO
P4-34	_____	G1 P3-	P7-34	_____	D1 P2-
33	_____	G2	33	_____	C1
26	_____	F1	26	_____	B1
25	_____	E1	25	_____	A1
22	_____	D1	22	_____	G1 P1-
21	_____	C1	21	_____	F1
10	_____	B1	10	_____	E1
9	_____	A1	9	_____	D1
2	_____	G1 P2-	2	_____	C1
1	_____	F1	1	_____	B1
P5-34	_____	F2 P3-	P8-34	_____	D2 P2-
33	_____	F3	33	_____	D3
26	_____	E2	26	_____	B2
25	_____	E3	25	_____	B3
22	_____	D2	22	_____	F2 P1-
21	_____	D3	21	_____	E2
10	_____	C2	10	_____	C2
9	_____	C3	9	_____	C3
2	_____	F2 P2-	2	_____	F2
1	_____	F3	1	_____	F3

31574-362.A00  
Rev. (A)

Figure 3–18. Wire Tables for Cable, P/N 38216-394-03

3.14. CABLE, SYSTEM BUS, P/N 38216-395-01 THRU -10

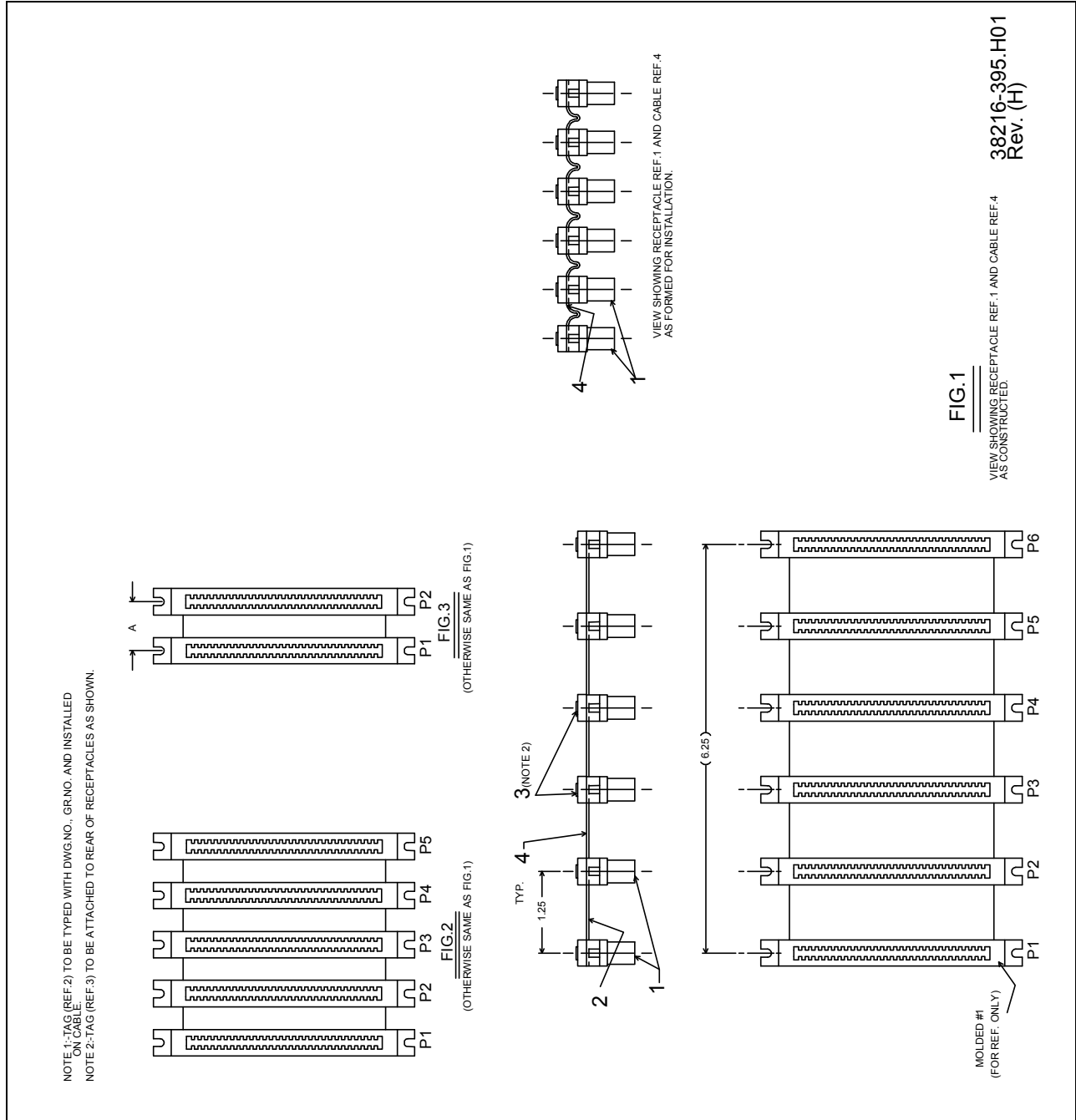
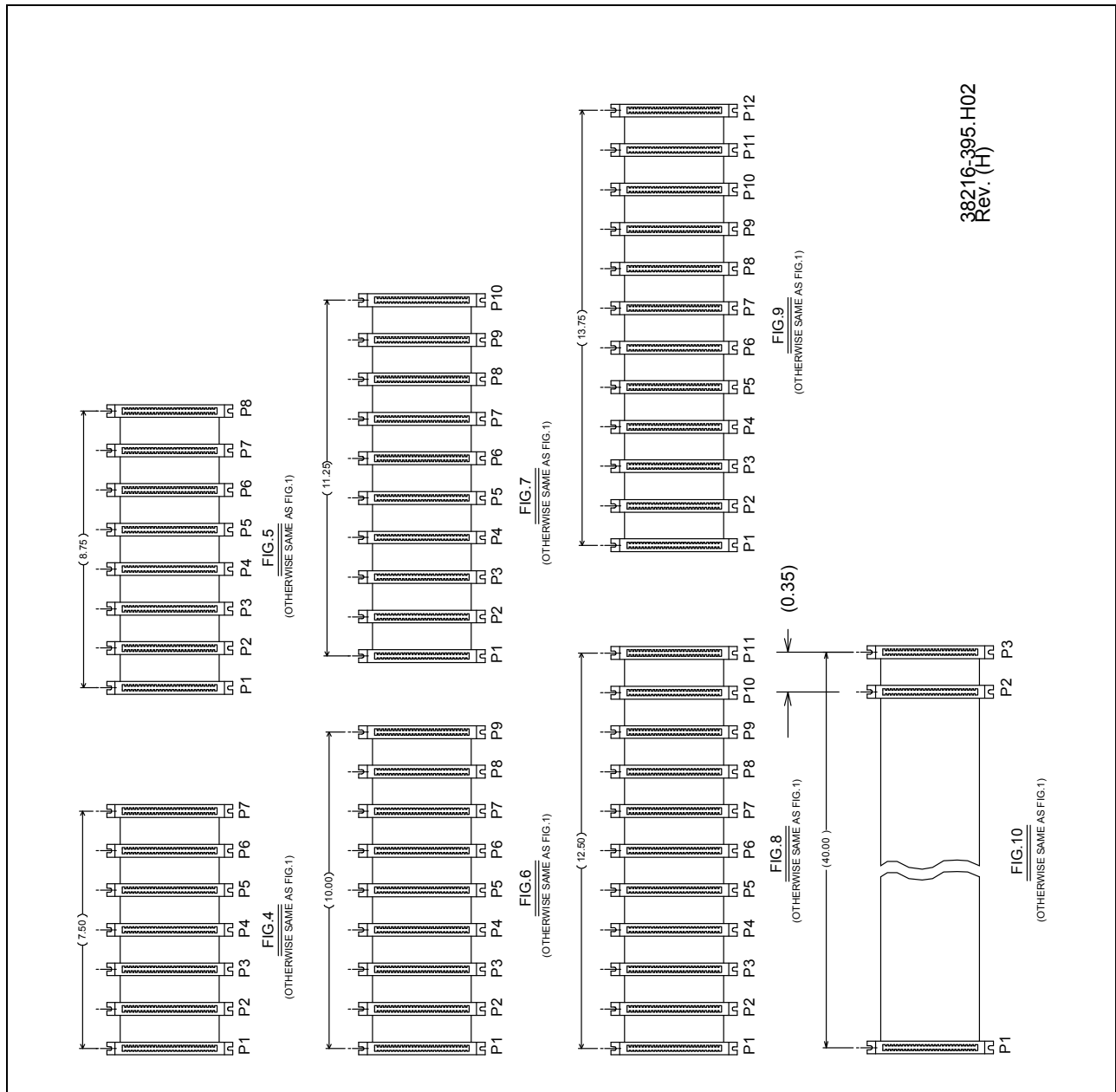

Figure 3-19. Cable, System Bus, P/N 38216-395-01 thru -10 (Sheet 1 of 2)



38216-395.H02  
Rev. (H)

Figure 3–19. Cable, System Bus, P/N 38216-395-01 thru -10 (Sheet 2 of 2)

3.15. CABLE, MODULE TO MODULE, P/N 38216-403-01

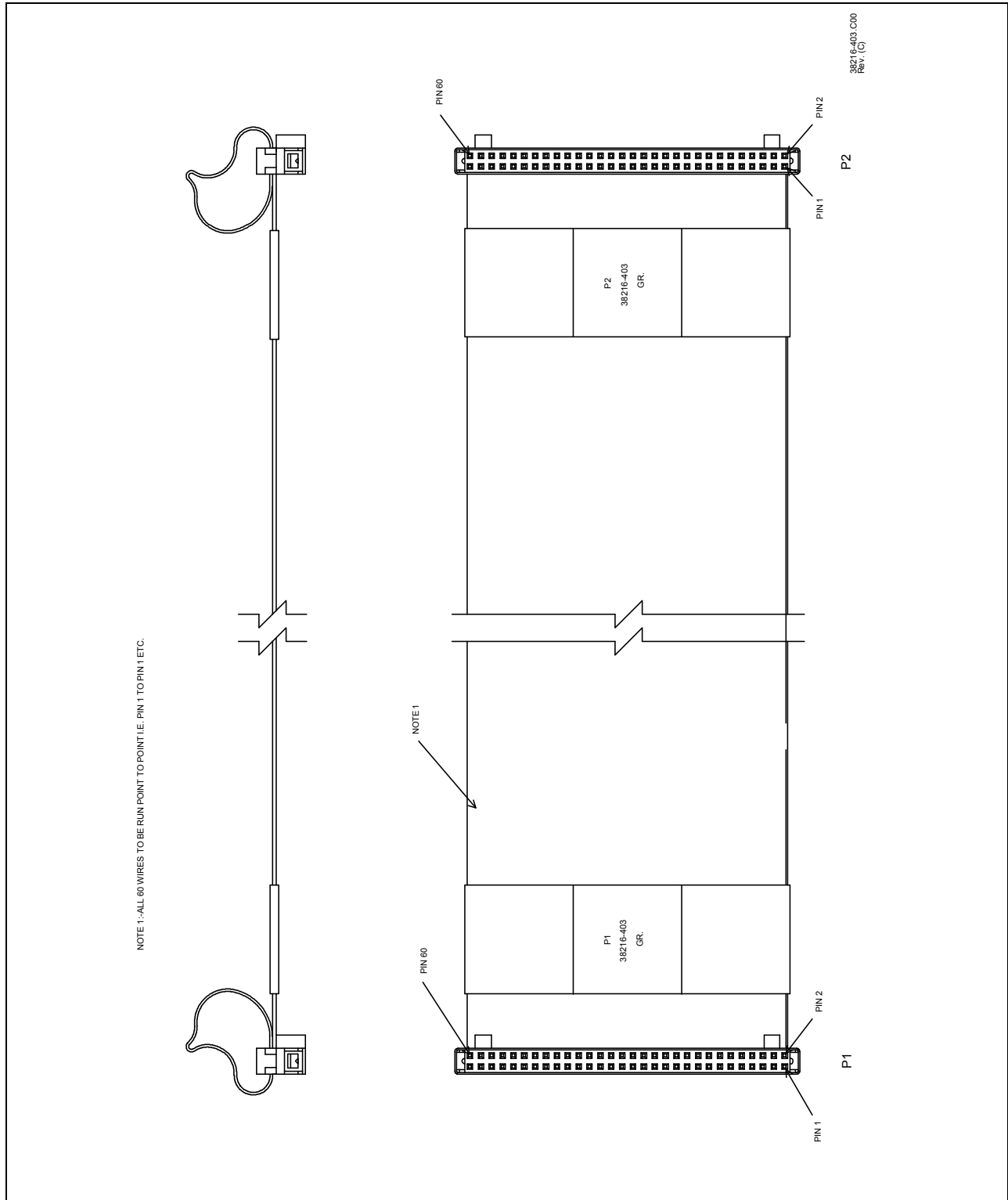

Figure 3–20. Cable, Module to Module, P/N 38216-403-01

3.16. CABLE, EXPANSION, P/N 38216-404-01 THRU -08

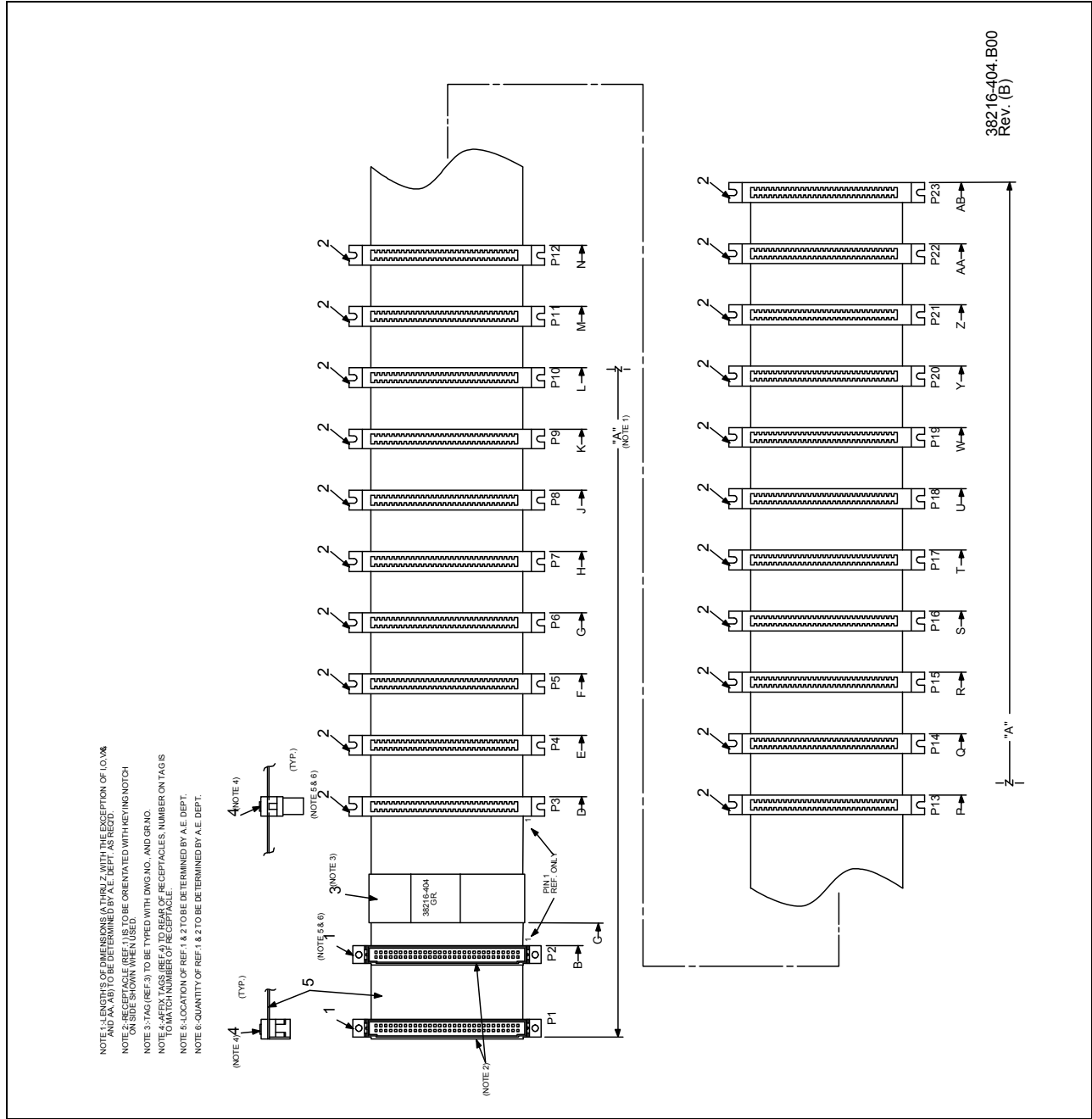

Figure 3-21. Cable, Expansion, P/N 38216-404-01 thru -08

3.17. CABLE, NON-VITAL I/O, P/N 38216-497-01 THRU -03

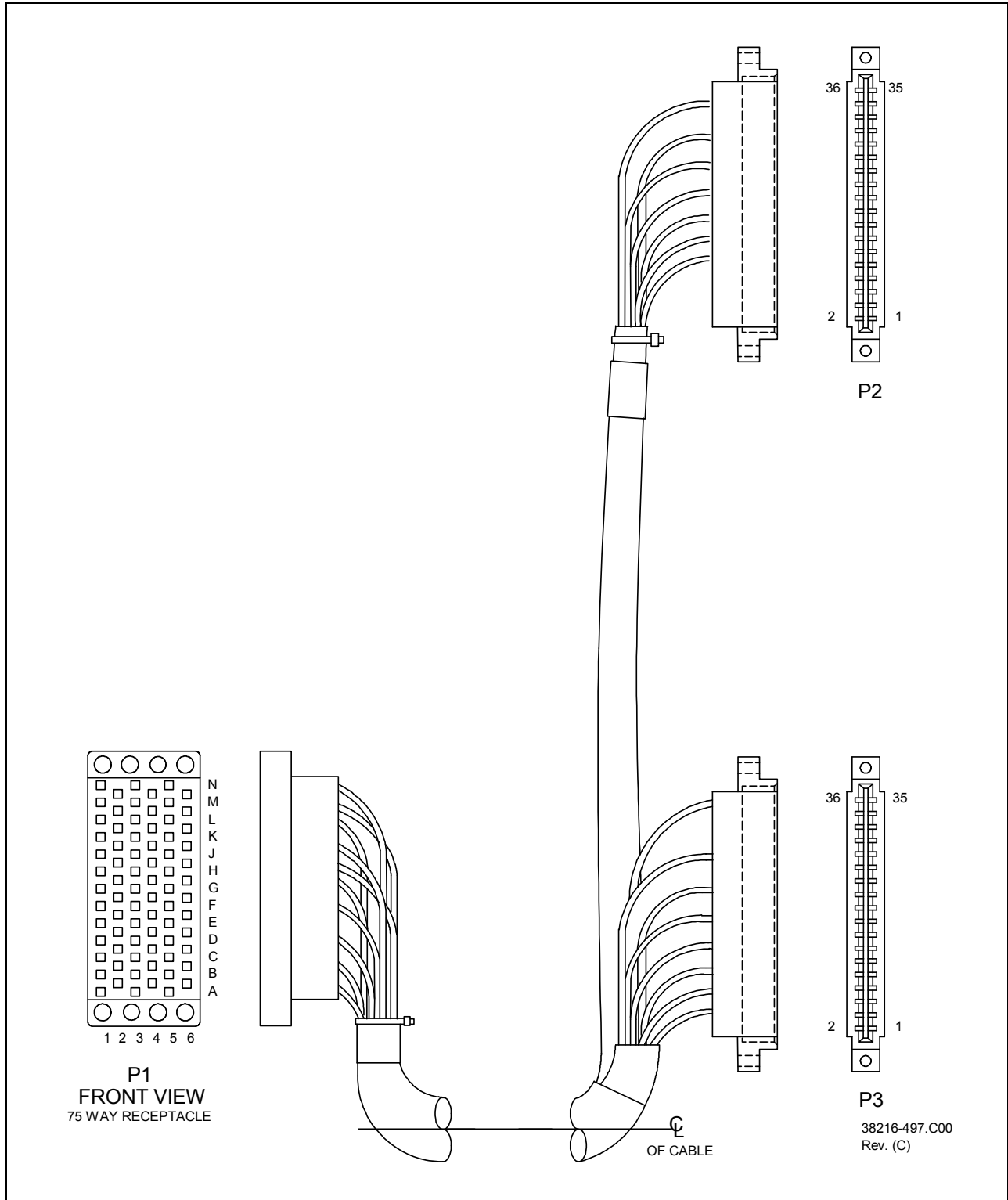

Figure 3-22. Cable, Non-Vital I/O, P/N 38216-497-01 thru -03

## Modules and Cables

FROM	WIRE	TO	FROM	WIRE	TO	FROM	WIRE	TO	FROM	WIRE	TO
P2-1	_____	G1	P2-19	_____	K1	P3-1	_____	A1	P3-19	_____	D1
2	_____	G2	20	_____	K2	2	_____	A2	20	_____	D2
3	_____	G3	21	_____	K3	3	_____	A3	21	_____	D3
4	_____	G4	22	_____	K4	4	_____	A4	22	_____	D4
5	_____	G5	23	_____	K5	5	_____	A5	23	_____	D5
6	_____	G6	24	_____	K6	6	_____	A6	24	_____	D6
7	_____	H1	25	_____	L1	7	_____	B1	25	_____	E1
8	_____	H2	26	_____	L2	8	_____	B2	26	_____	E2
9	_____	H3	27	_____	L3	9	_____	B3	27	_____	E3
10	_____	H4	28	_____	L4	10	_____	B4	28	_____	E4
11	_____	H5	29	_____	L5	11	_____	B5	29	_____	E5
12	_____	H6	30	_____	L6	12	_____	B6	30	_____	E6
13	_____	J1	31	_____	M1	13	_____	C1	31	_____	F1
14	_____	J2	32	_____	M2	14	_____	C2	32	_____	F2
15	_____	J3	33	_____	M3	15	_____	C3	33	_____	F3
16	_____	J4	34	_____	M4	16	_____	C4	34	_____	F4
17	_____	J5	35	_____	M5	17	_____	C5	35	_____	F5
18	_____	J6	36	_____	M6	18	_____	C6	36	_____	F6

31574-435.A00  
Rev. (A)

Figure 3–23. Wire Tables for Cable, P/N 38216-497-01 thru –03

3.18. CONNECTOR, PLUG, 14-WAY, P/N 58920-113-00

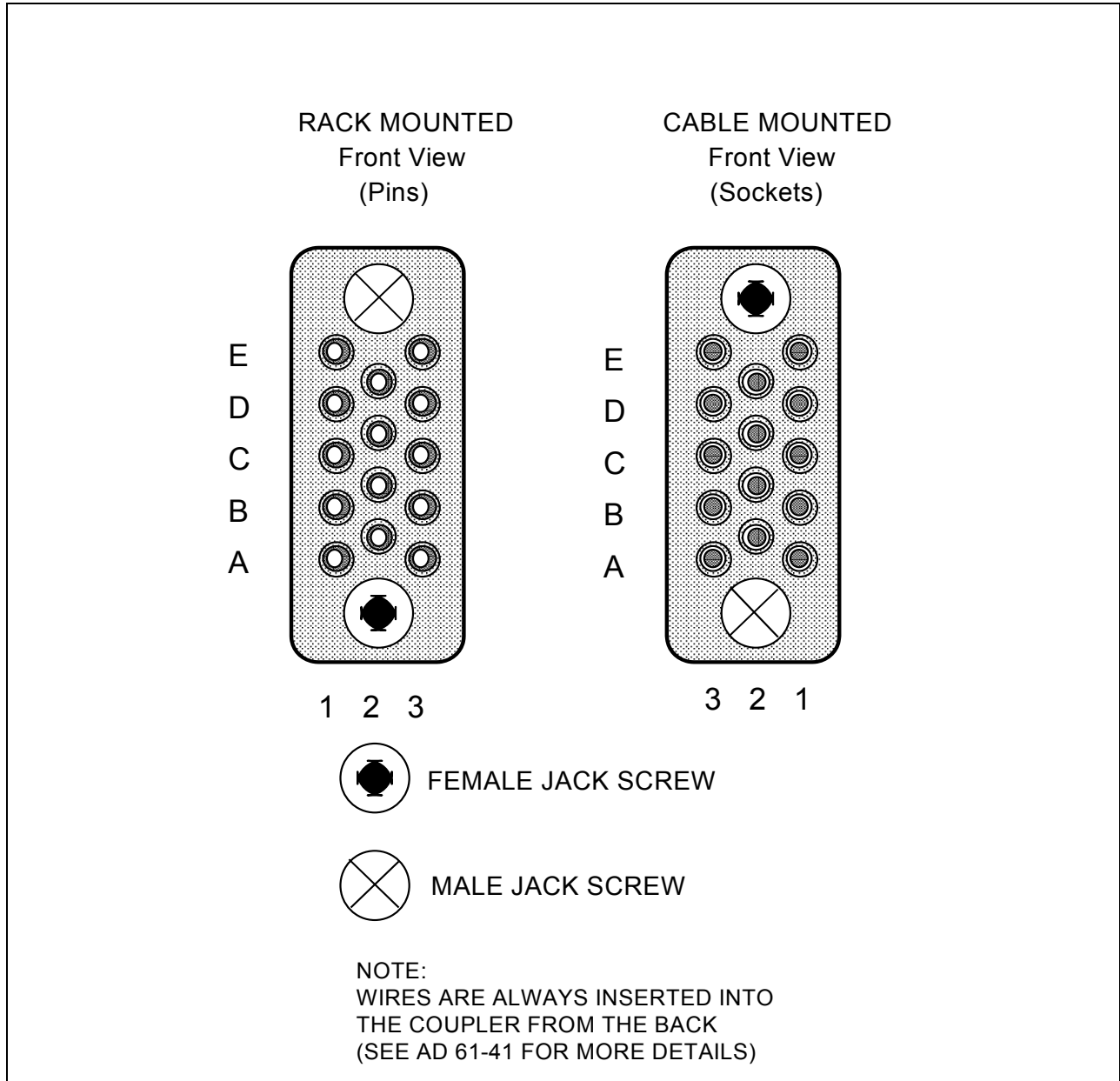

Figure 3-24. Connector, Plug, 14-Way, P/N 58920-113-00

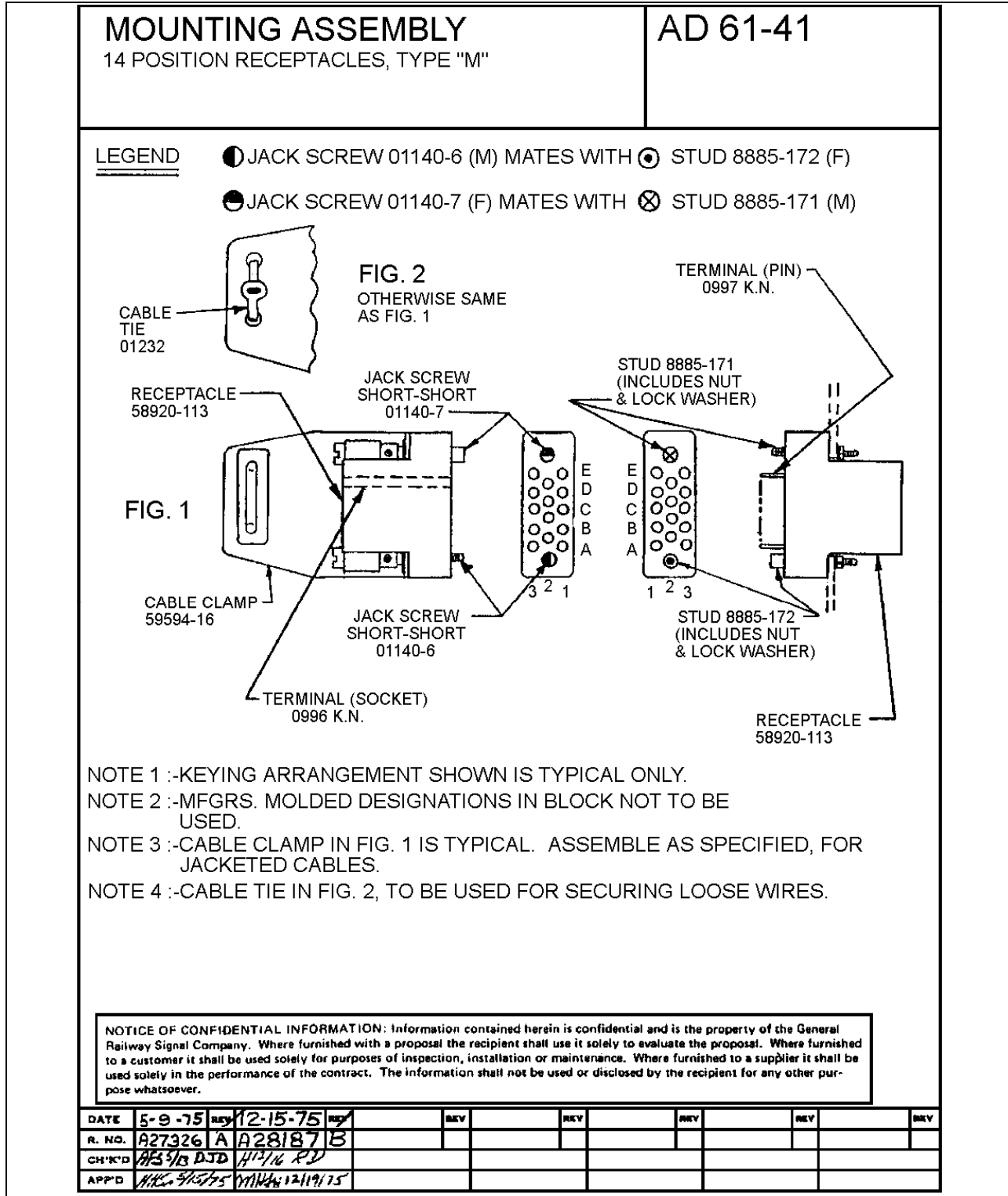

Figure 3-25. Connector, Plug, 14-Way Mounting Assembly, AD61-41

3.19. CONNECTOR, PLUG, 28-WAY, P/N 58920-124-00

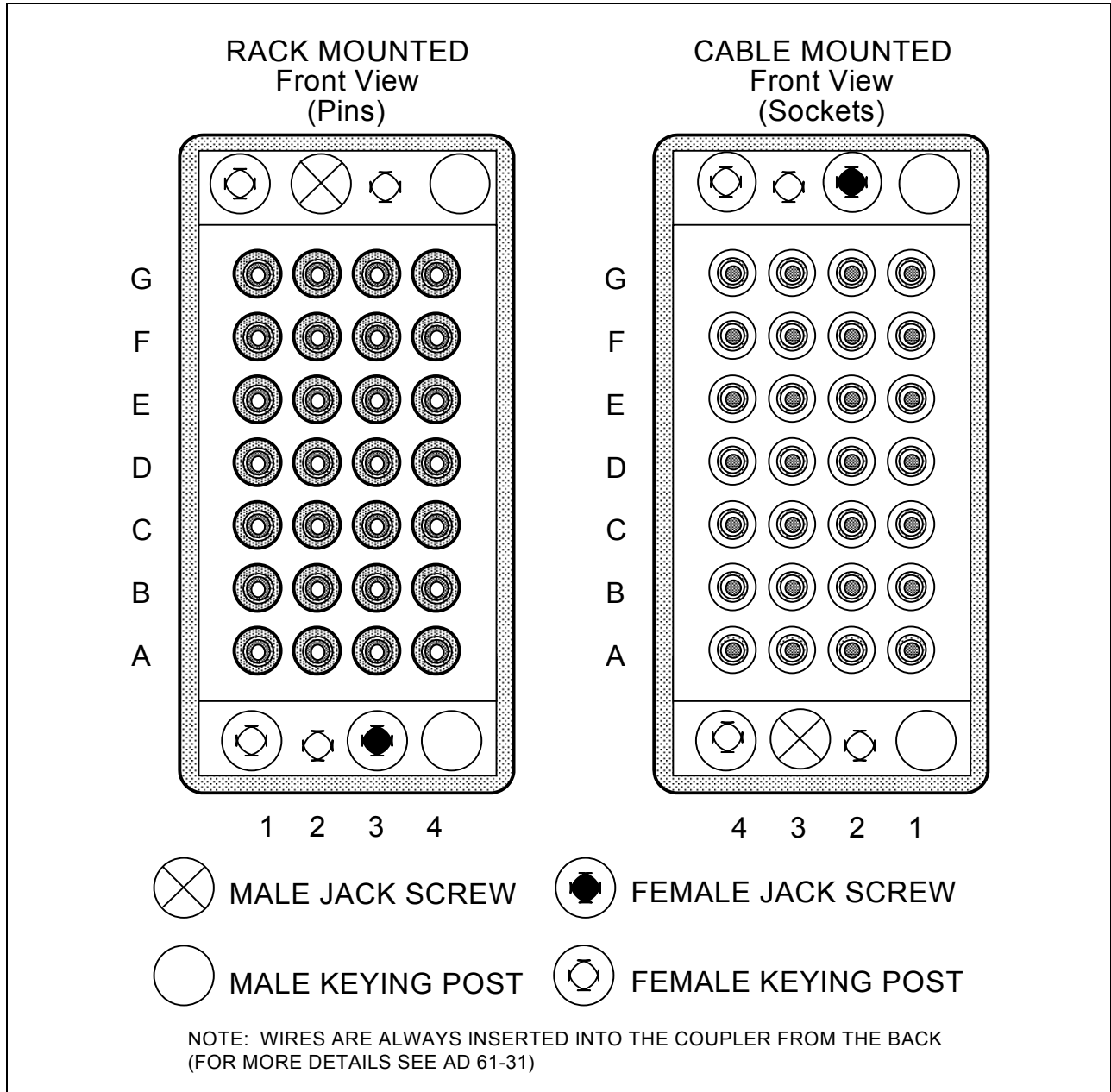

Figure 3–26. Connector, Plug, 28-Way, P/N 58920-124-00

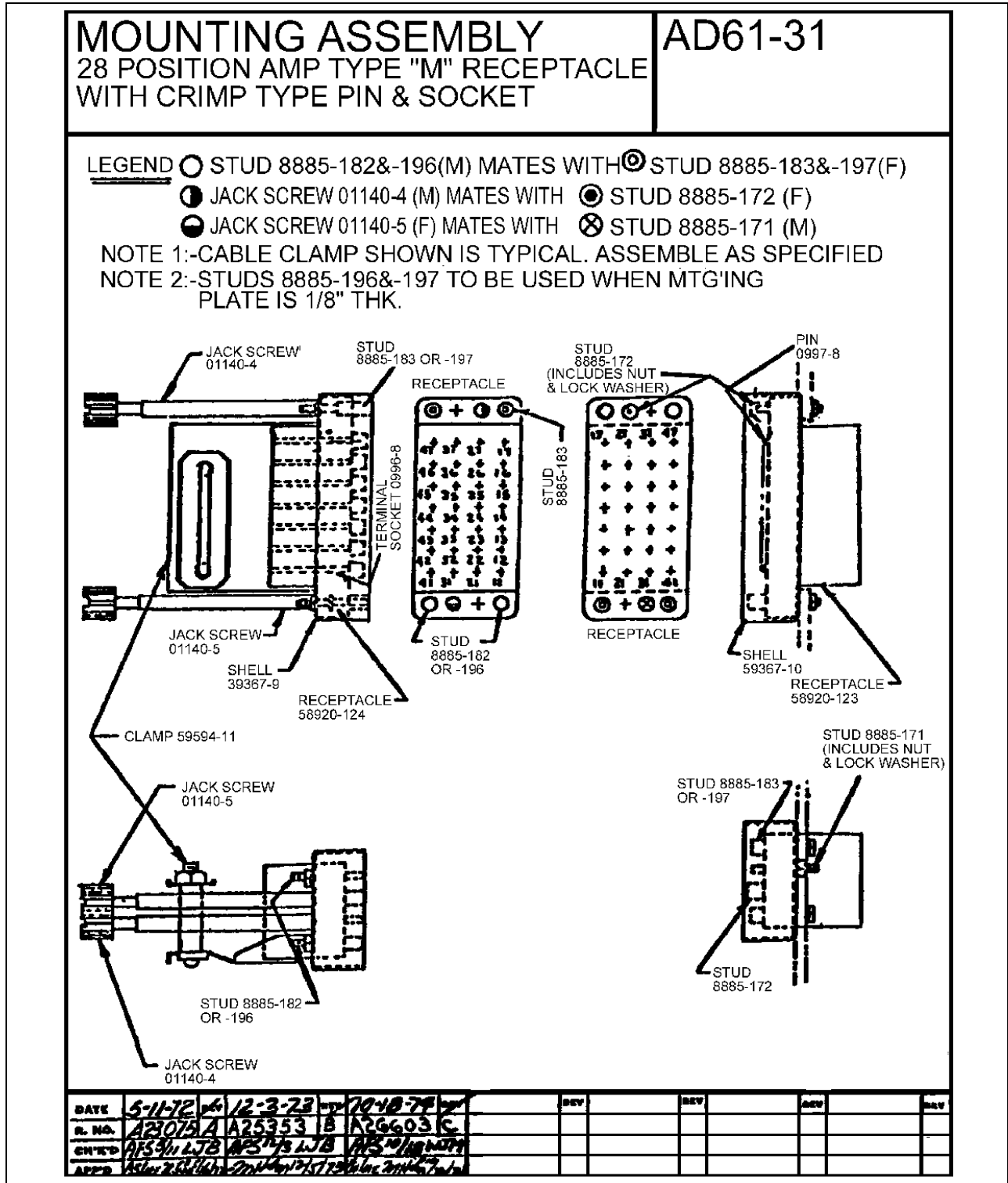

Figure 3-27. Connector, Plug, 28-Way, Mounting Assembly, AD61-31

3.20. CONNECTOR, PLUG, 50-WAY, P/N 58920-112-00

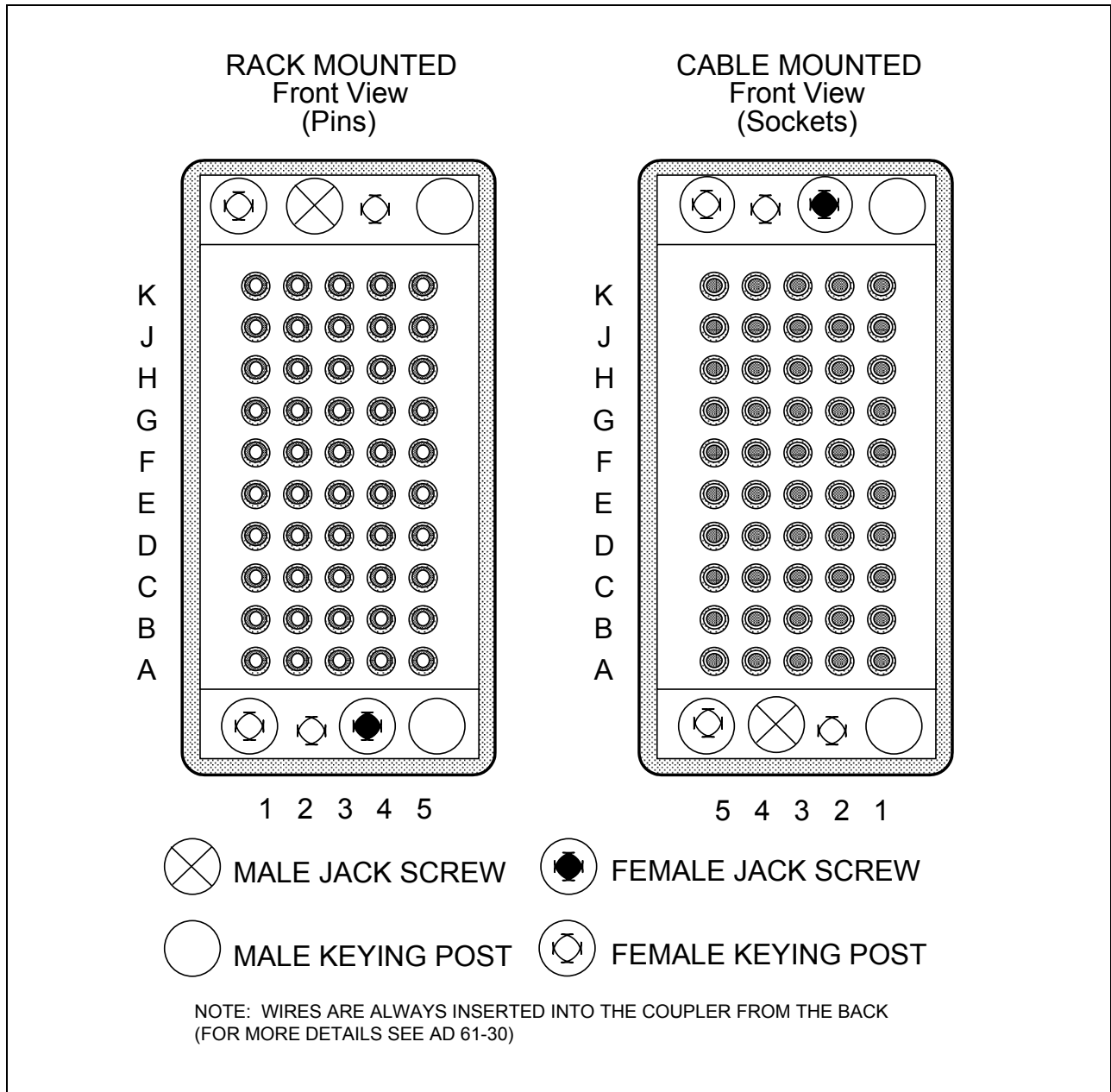

Figure 3–28. Connector, Plug, 50-Way, P/N 58920-112-00

3.21. CONNECTOR, PLUG, 75-WAY, P/N 58920-116-00

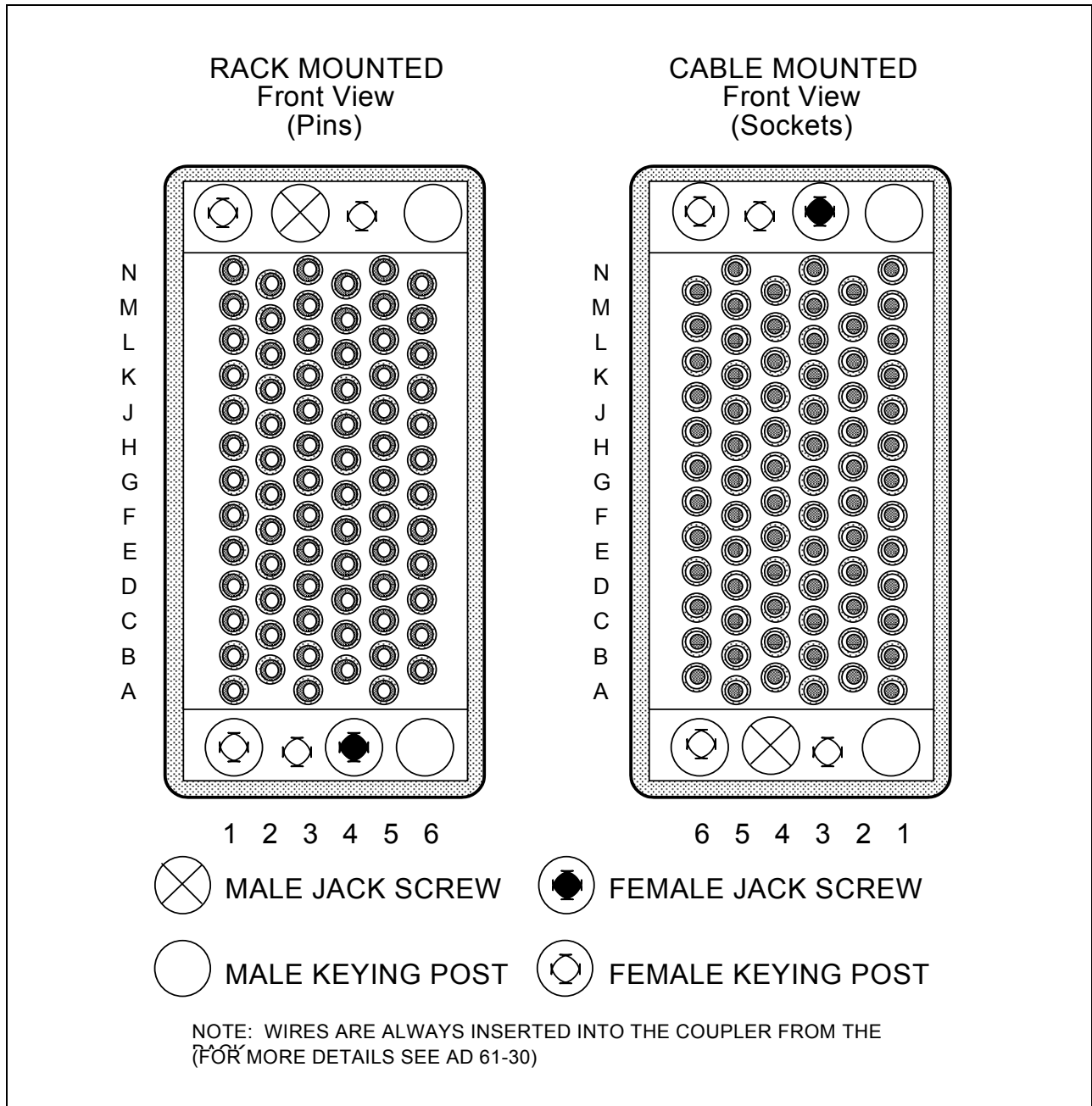

Figure 3-29. Connector, Plug, 75-Way, P/N 58920-116-00

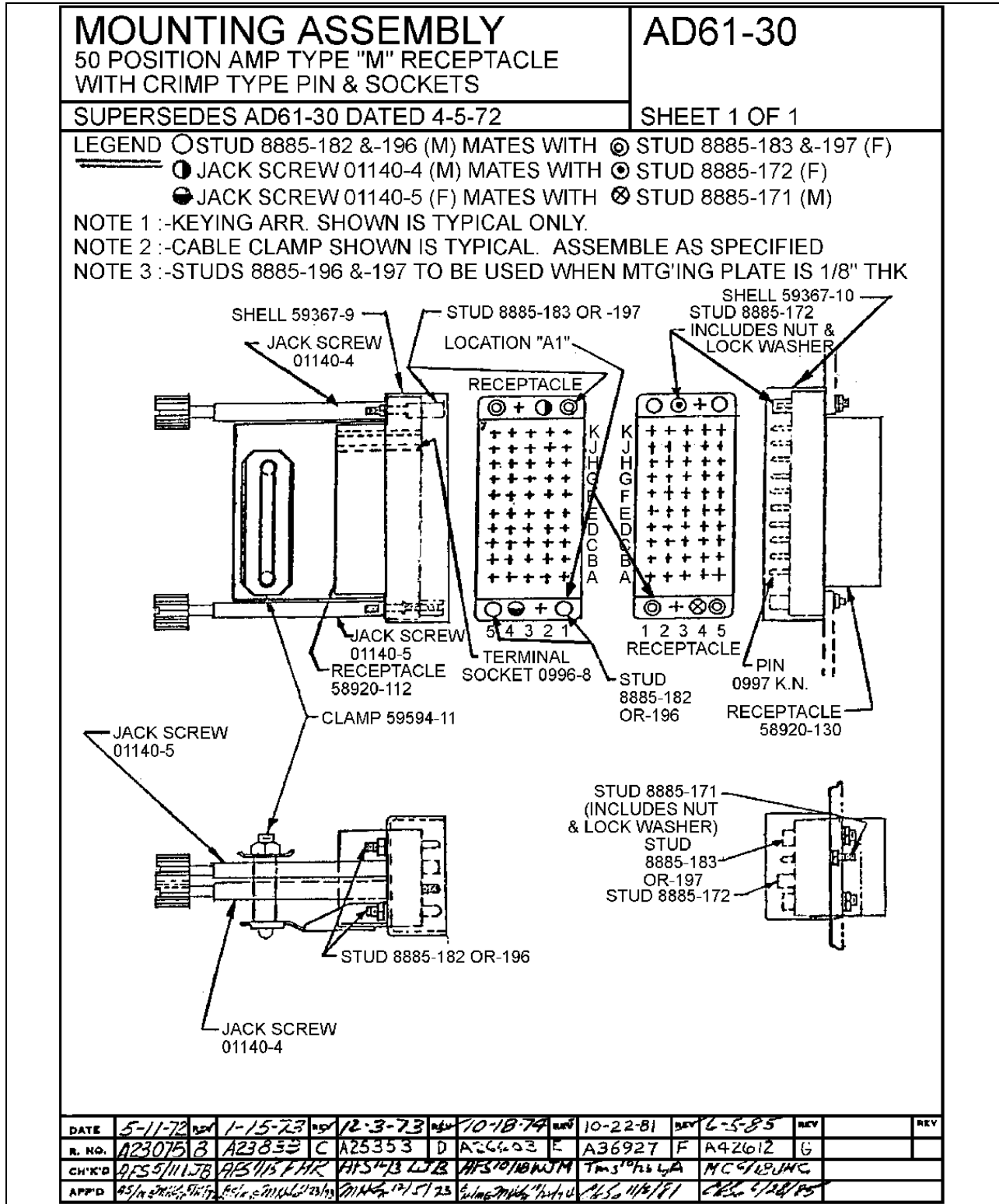

Figure 3-30. Connector, Plug, 50-Way and 75-Way, Mounting Assembly, AD61-30

3.22. RECEPTACLE KEYING PLAN FOR SYSTEM MODULE, P/N 31038-249-00

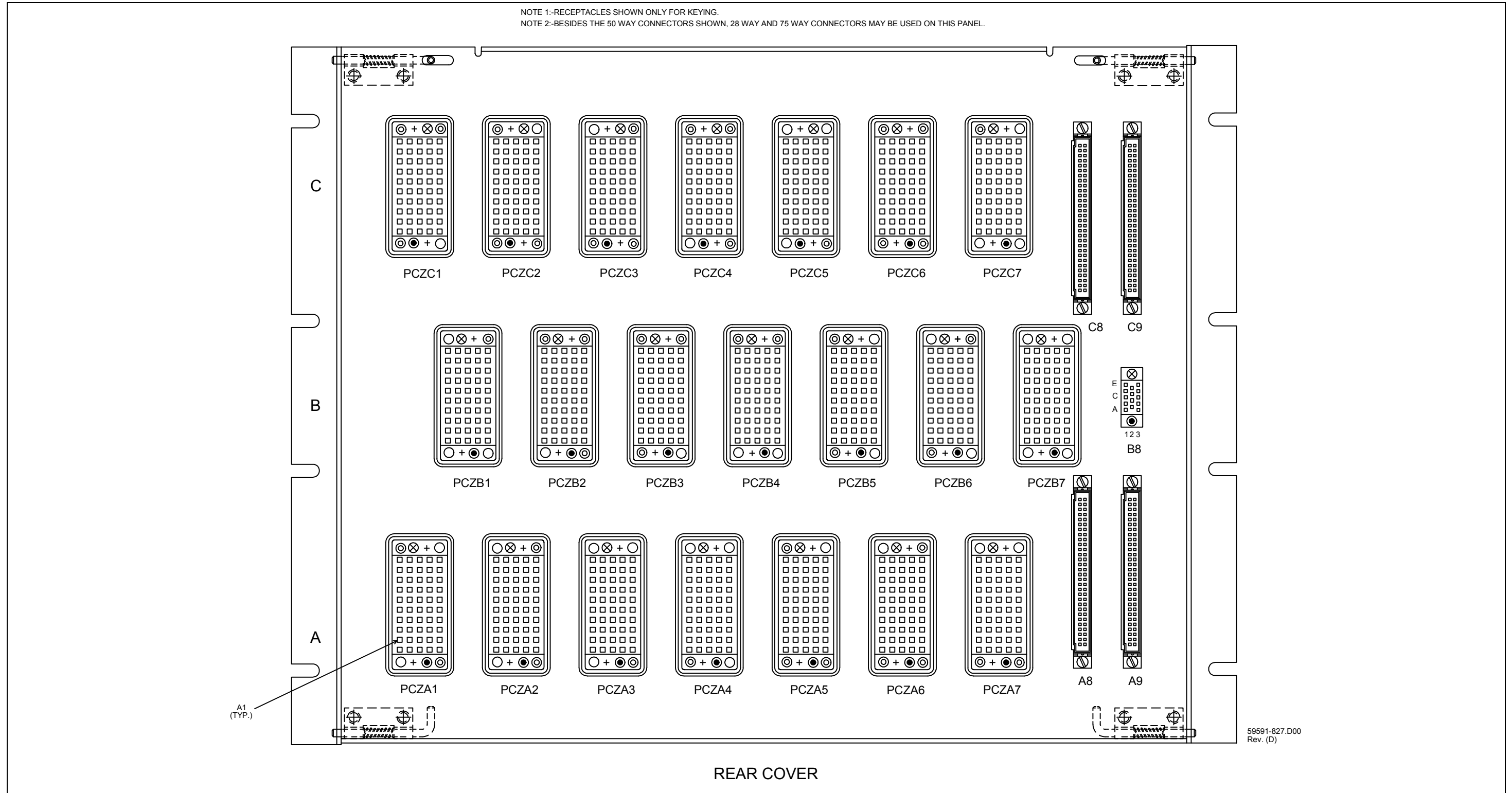

Figure 3-31. Receptacle Keying Plan for System Module, P/N 31038-249-00

3.23. 28-WAY CONNECTOR COMPLETE, P/N 42758-127-01 THRU -25

NOTE 1:- REFER TO AD61-31 FOR ASSEMBLY U-BOLT SHALL FACE CENTER OF CONNECTOR BLOCK. NUTS & U-BOLT THD. ENDS SHALL BE WITHIN OVERALL CONNECTOR.

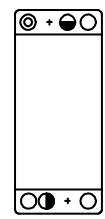
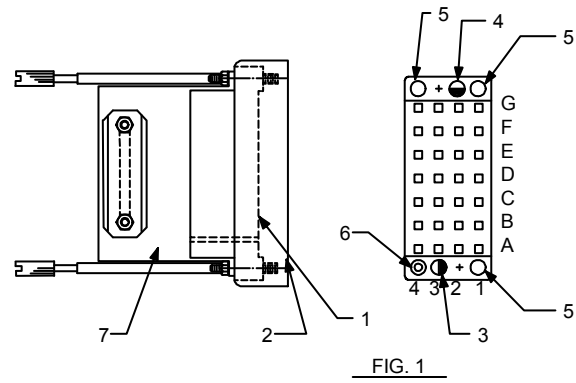

FIG. 2



FIG. 3

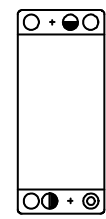

FIG. 4

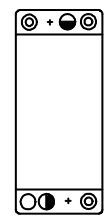

FIG. 5



FIG. 6



FIG. 7



FIG. 8

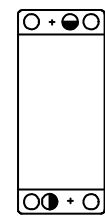

FIG. 9

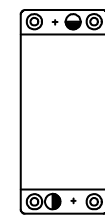

FIG. 10



FIG. 11

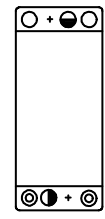

FIG. 16



FIG. 17



FIG. 18



FIG. 19

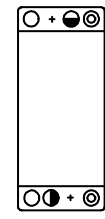

FIG. 20

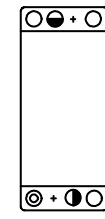

FIG. 21

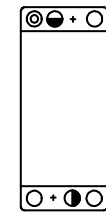

FIG. 22



FIG. 23

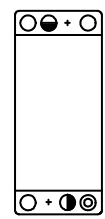

FIG. 24



FIG. 25

42758-127.A00  
Rev. (A)

Figure 3-32. 28-Way Connector Complete, P/N 42758-127-01 thru -25

3.24. 50-WAY CONNECTOR COMPLETE, P/N 42758-093-01 THRU -25

NOTE 1:- REFER TO AD61-30 FOR ASSEMBLY U-BOLT SHALL FACE CENTER OF CONNECTOR BLOCK. NUTS & U-BOLT THD. ENDS SHALL BE WITHIN OVERALL CONNECTOR.

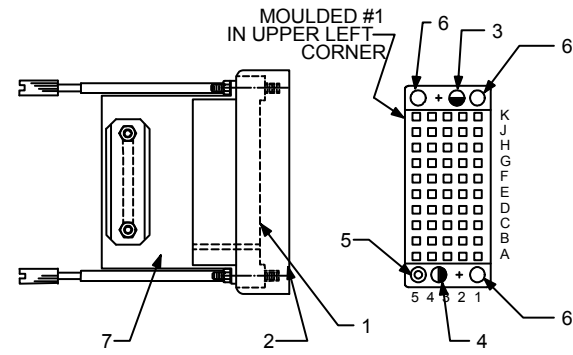

FIG. 1



FIG. 2

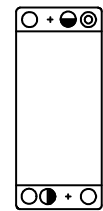

FIG. 3



FIG. 4



FIG. 5



FIG. 6



FIG. 7



FIG. 8



FIG. 9



FIG. 10

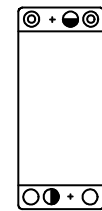

FIG. 11



FIG. 12



FIG. 13

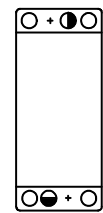

FIG. 14



FIG. 15



FIG. 16



FIG. 17



FIG. 18



FIG. 19



FIG. 20



FIG. 21

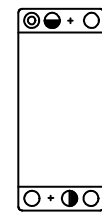

FIG. 22



FIG. 23



FIG. 24

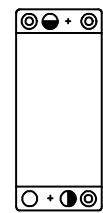

FIG. 25

42758-093.C00  
Rev. (C)

Figure 3-33. 50-Way Connector Complete, P/N 42758-093-01 thru -25

3.25. 75-WAY CONNECTOR COMPLETE, P/N 42758-134-01 THRU -25

NOTE 1:- REFER TO AD61-30 FOR ASSEMBLY. U-BOLT SHALL FACE CENTER OF CONNECTOR BLOCK.  
NUTS AND U-BOLT THD. ENDS SHALL BE WITHIN OVERALL CONNECTOR.

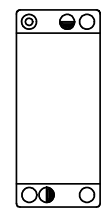
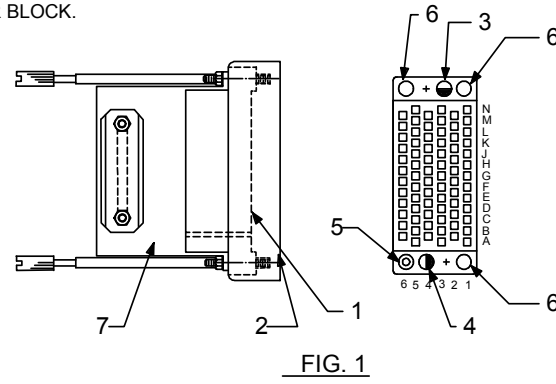

FIG. 2

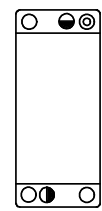

FIG. 3



FIG. 4



FIG. 5



FIG. 6



FIG. 7



FIG. 8

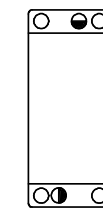

FIG. 9

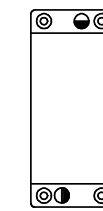

FIG. 10



FIG. 11



FIG. 16



FIG. 17

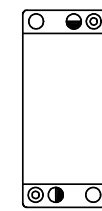

FIG. 18



FIG. 19

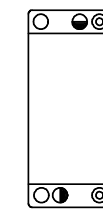

FIG. 20

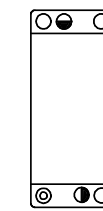

FIG. 21



FIG. 22



FIG. 23

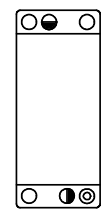

FIG. 24

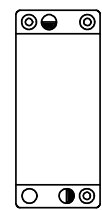

FIG. 25

42758-134.A00  
Rev. (A)

Figure 3-34. 75-Way Connector Complete, P/N 42758-134-01 thru -25

3.26. DC/DC CONVERTER, P/N 42560-273-01 THRU -08

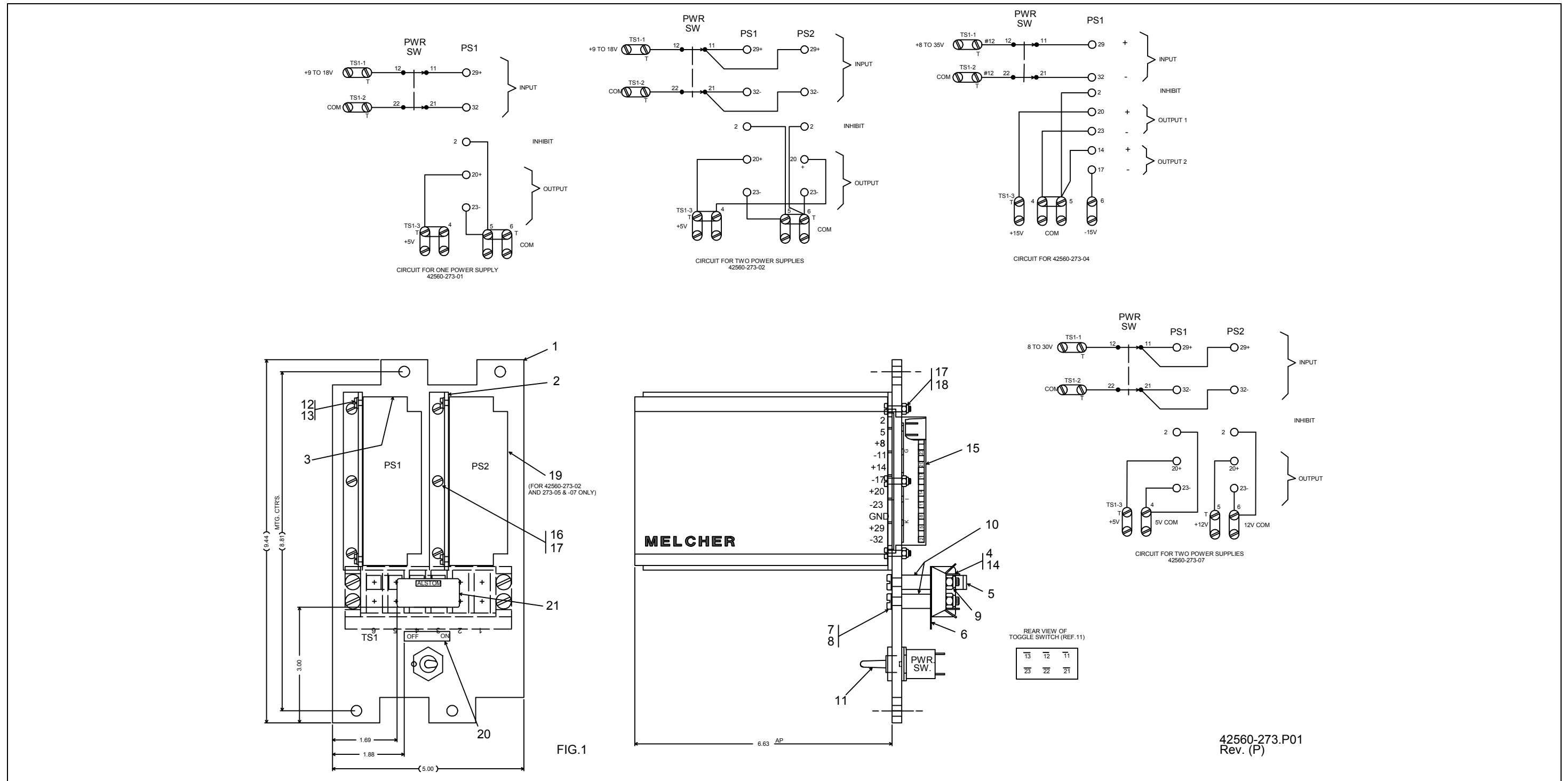

Figure 3-35. DC/DC Converter, P/N 42560-273-01 thru -08 (Sheet 1 of 3)

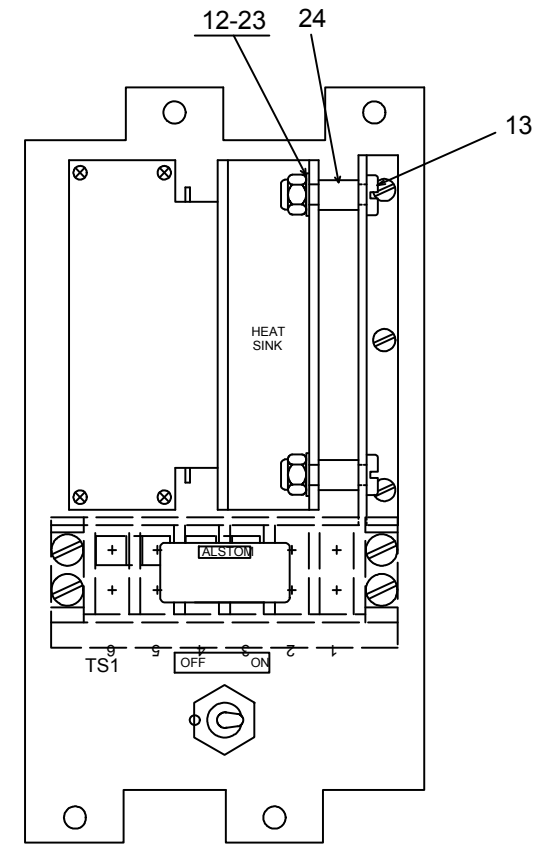
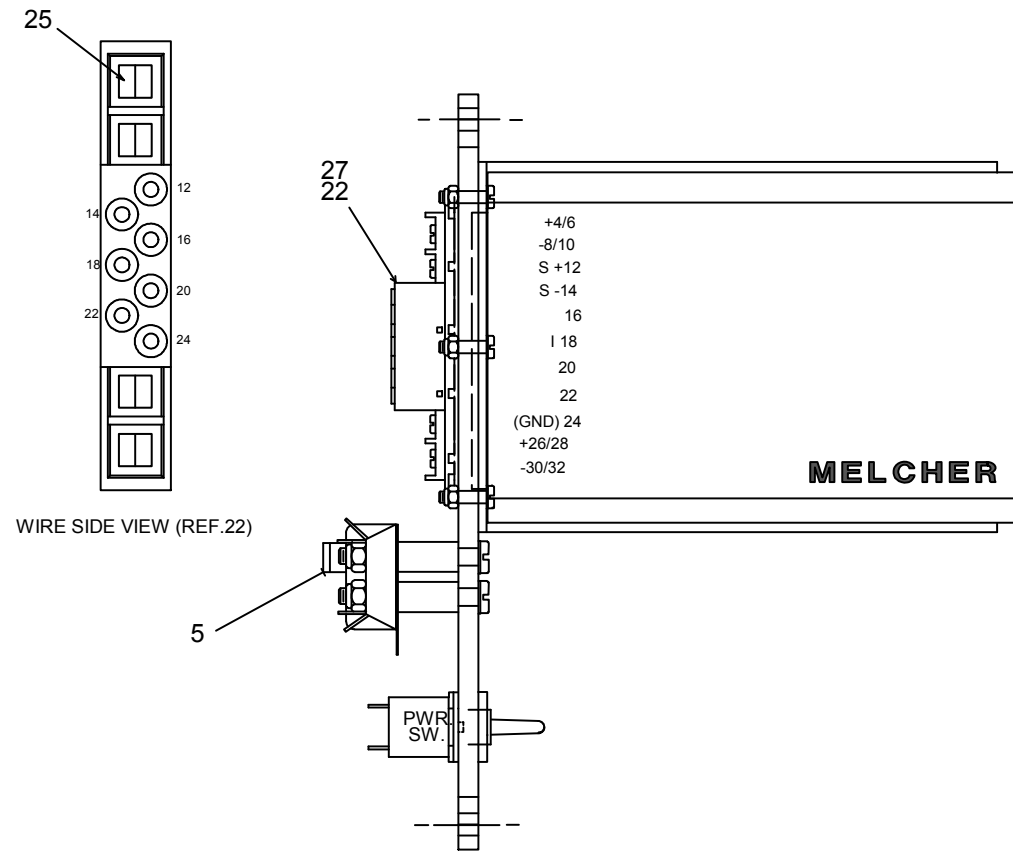
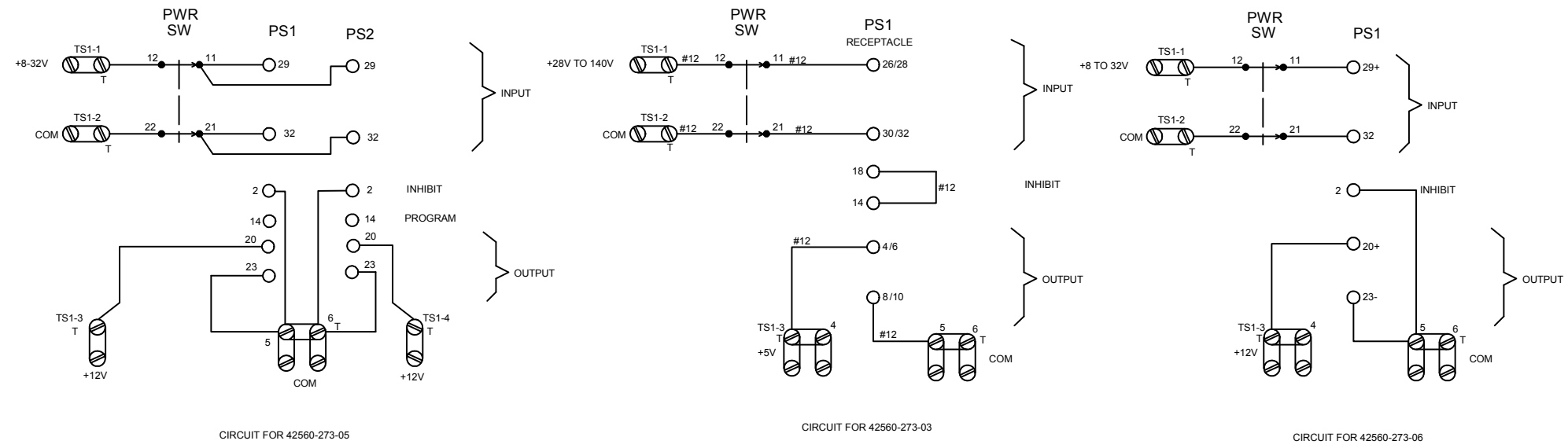
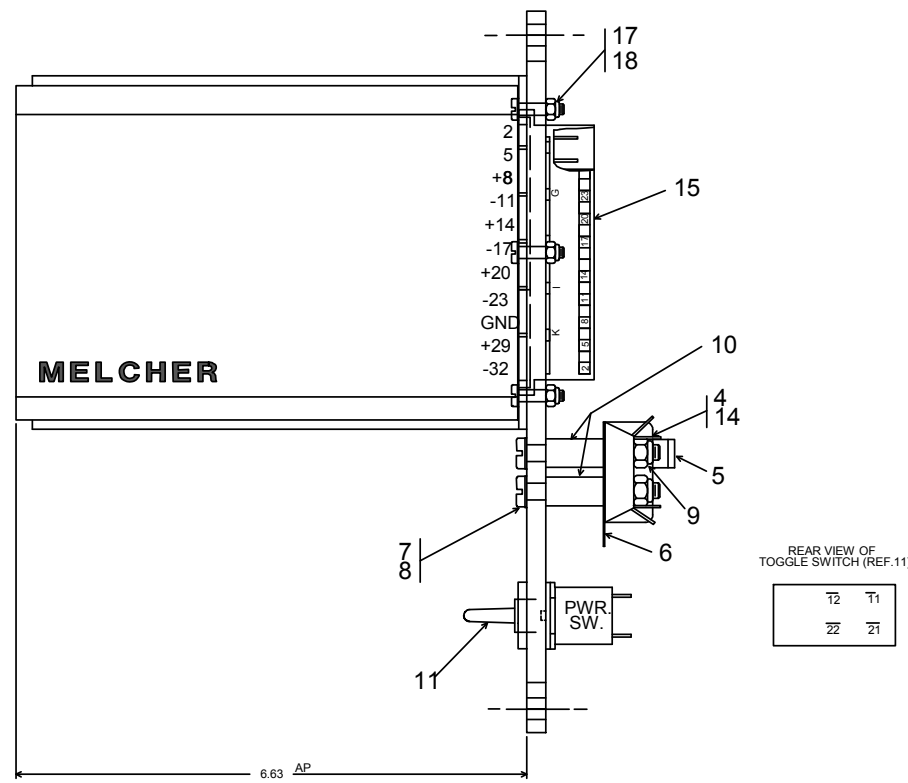
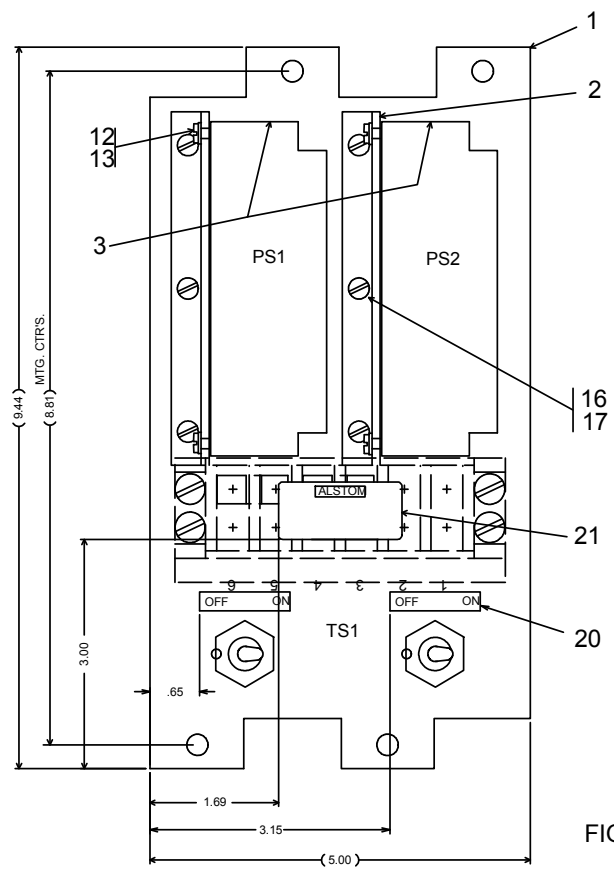
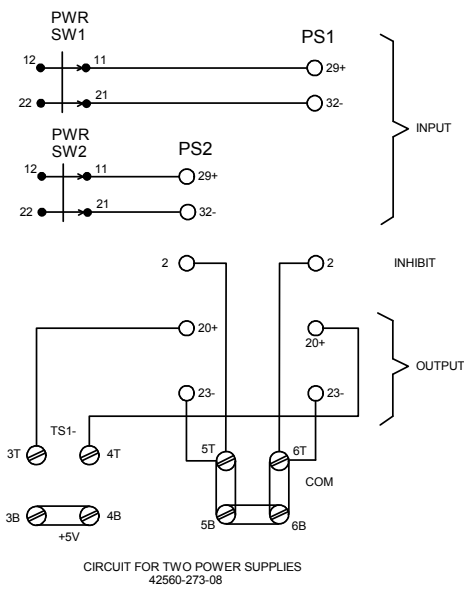

FIG.2  
FOR 42560-273-03 ONLY  
(OTHERWISE SAME AS FIG.1)

42560-273.P02  
Rev. (P)

Figure 3-35. DC/DC Converter, P/N 42560-273-01 thru -08 (Sheet 2 of 3)



42560-273.P03  
Rev. (P)

Figure 3-35. DC/DC Converter, P/N 42560-273-01 thru -08 (Sheet 3 of 3)

### 3.27. EXTENDER BOARDS

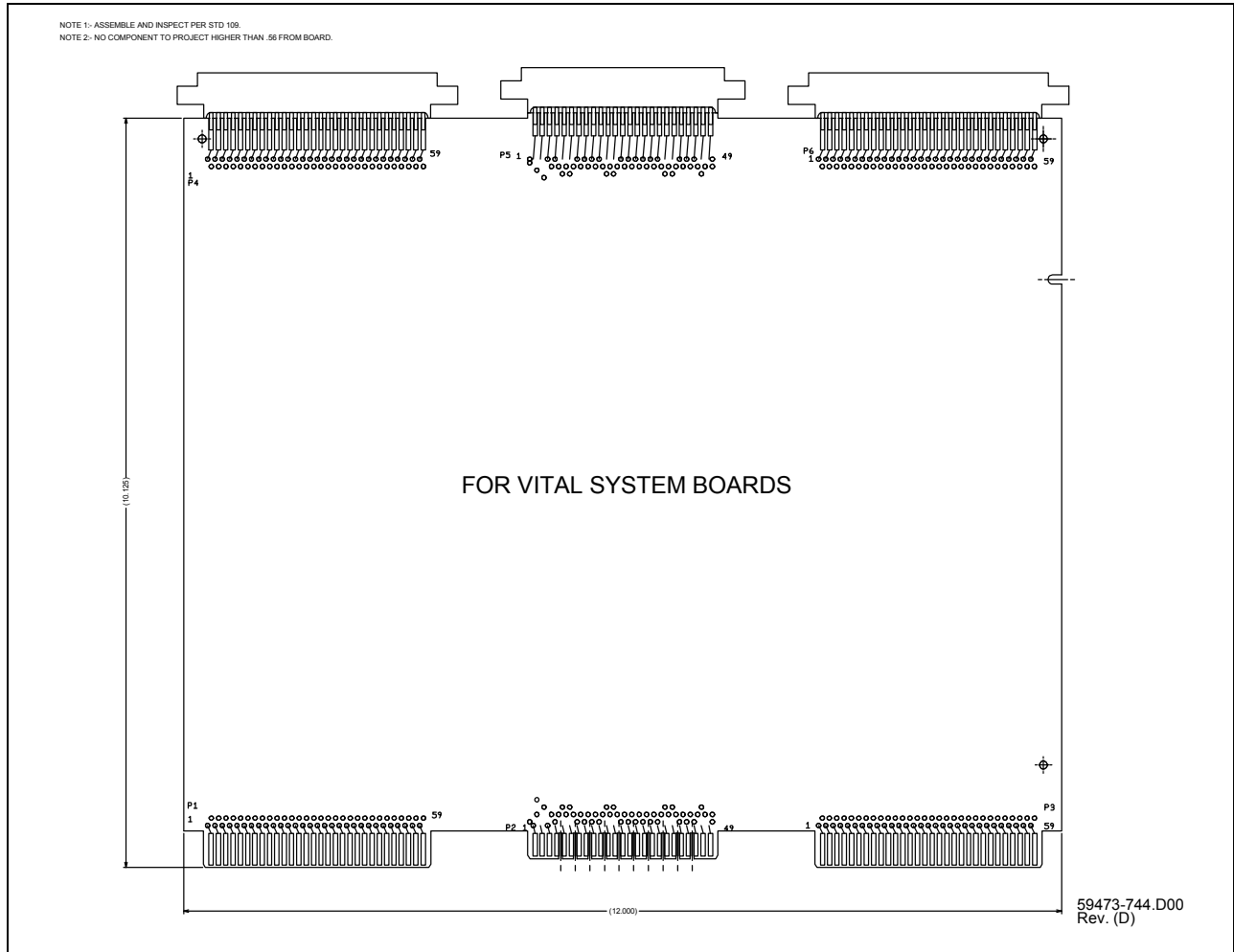

Figure 3-36. Extender Board, P/N 59473-744-01

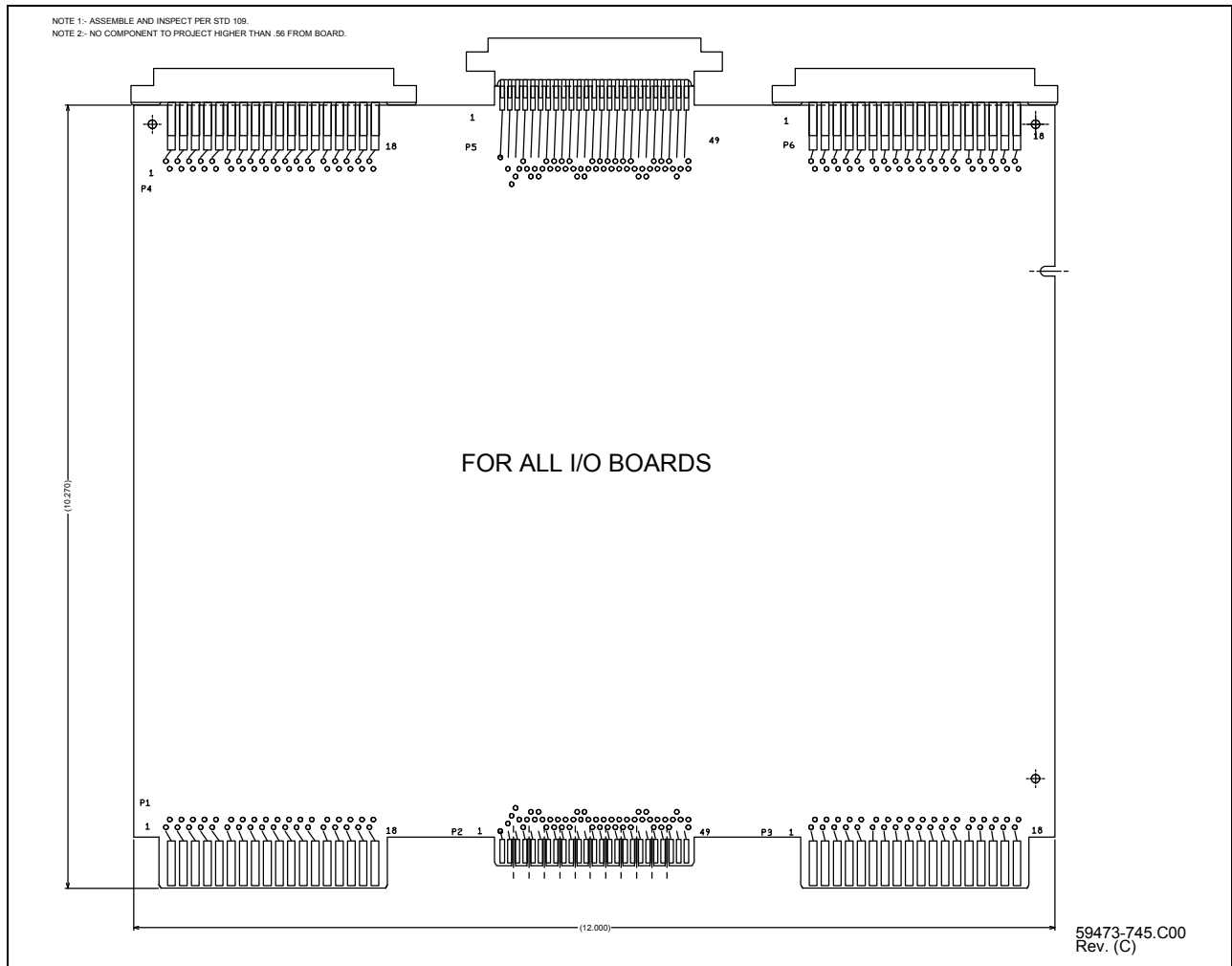

Figure 3-37. Extender Board, P/N 59473-745-01

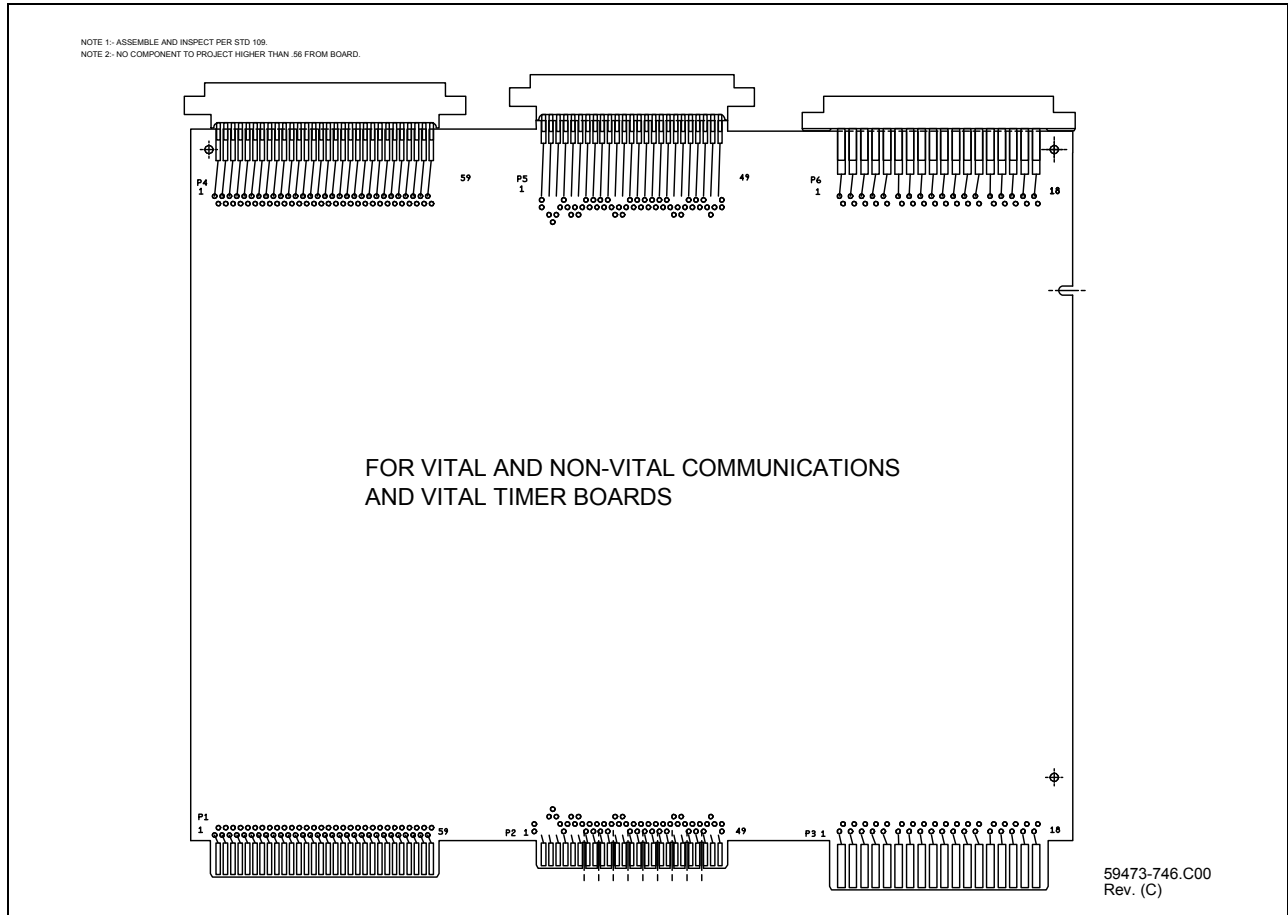

Figure 3–38. Extender Board, P/N 59473-746-01

3.28. RELAY, B1 NEUTRAL, REGULAR RELEASE, 100 OHM (USED WITH VRD BOARD), P/N 56001-787-05

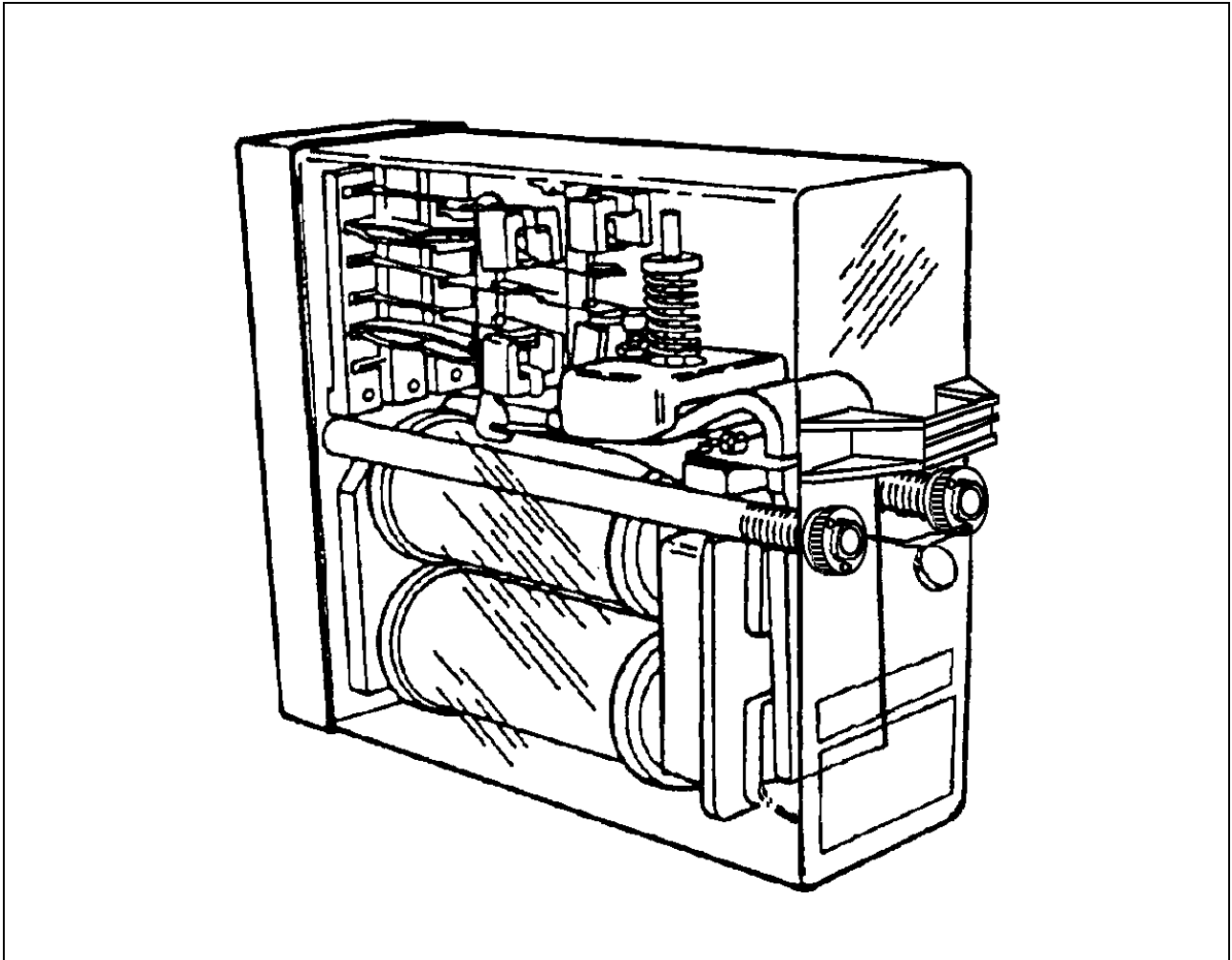

Figure 3–39. Relay, B1 Neutral, Regular Release, 100 Ohm (Used with VRD Board), P/N 56001-787-05

## 4. SECTION 4 – SPECIAL TOOLS

### 4.1. GENERAL

This section shows the special tools used for the VPI II chassis.

Table 4–1 provides list of special tools required to assemble or repair the 28-, 36-, 50-, and 75-way connectors, and the communications DB-9 and DB-25 connectors. The table includes part numbers and references to Figures 4–1 through 4–12. To see the drawing for the Special Tool, go to the reference column and cross-reference the figure number to the corresponding drawing number within this section.

In some cases, a particular tool may require a separate die for various terminal types or wire sizes. Therefore, it may be necessary to reference more than one part number for a hand crimping tool or extractor. When more than one number is used, the person ordering must find out what gauge wire and corresponding part number is being used to order the correct crimping die.

Some VPI II racks may have connections from the entrance racks to the rear plane of the VPI II Module made as direct wiring and not with wires terminated in plug couplers. Over time, perhaps some of the wires may have been pulled on, leaving the wires either loose or pulled out of the crimp terminal. If this is the case, then 16-20 gauge wires can be reattached to the module with the proper size terminals and crimping tools.

The following pages in this section show the special tools required to assembly or repair the 28-, 36-, 50-, and 75-way connectors, plus the communications DB-9 and DB-25 connectors.

Table 4–1. Special Wiring Tools

Figure Ref.	Description	Part Number	OEM Supplier	Terminal Part Number
4–1	Extractor, B Relay Terminal	59688-000-00	N/A	55871-019-00
4–2	Amp Terminal Extraction Tool	59688-048-00	AMP 91703-1	55871-076-00 55871-082-00 55871-145-00 55871-150-00 55871-153-00 55871-176-00
4–3	Extractor, Type M	59688-005-00	AMP 305183	00996-007-ON 00996-009-ON 00997-009-ON 00997-011-ON
4–4	Extractor, Gold Leaf	59688-009-00	AMP 465195-1	55871-053-00 55871-048-00
4–5	Insertion/Extractor, #24-20	59688-018-00	AMP 91285-1	55871-089-00 55871-090-00
4–6	Hand Crimp Tool, Shield Crimping Die (3 sizes) .144 to .162, .168 to .185, .186 to .201	---	T&B WT740 T&B 301G, 301H, 301J	00923-012-ON
4–7	Hand Crimp Tool, Type M, #22-20	24745-048-00	AMP 90067-4	00996-007-ON 00996-009-ON 00997-009-ON 00997-011-ON
4–8	Hand Crimp Tool, AMP	24745-074-00	AMP 583649-6	55871-076-00
4–9	Hand Crimp Tool, Type C, #24-20	24745-087-00	AMP 90302-1	55871-089-00 55871-090-00
4–10	Hand Crimp Tool, Twin Leaf	24745-126-00	AMP 90264-1	55871-150-00 55871-076-00
4–11	Hand Crimp Tool, Ring, #22-16	24745-145-00	AMP 59824-1	59825-233-00
4–12	Hand Crimp Tool, AMP	24745-149-00	AMP 90285-1	55871-145-00 55871-153-00



Note: This tool for Alstom terminal P/N 55871-019-00

Figure 4-1. Extractor, B Relay Terminal, P/N 59688-000-00

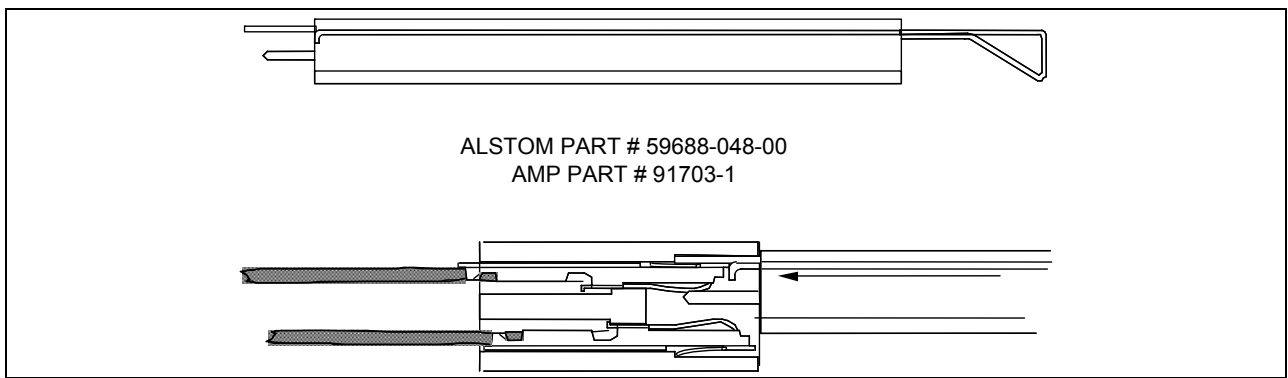

Note: This tool for Alstom terminal P/N 55871-076-00, 55871-082-00, 55871-145-00, 55871-150-00, 55871-153-00, and 55871-176-00

Figure 4-2. Extractor, Gold Leaf, P/N 59688-048-00

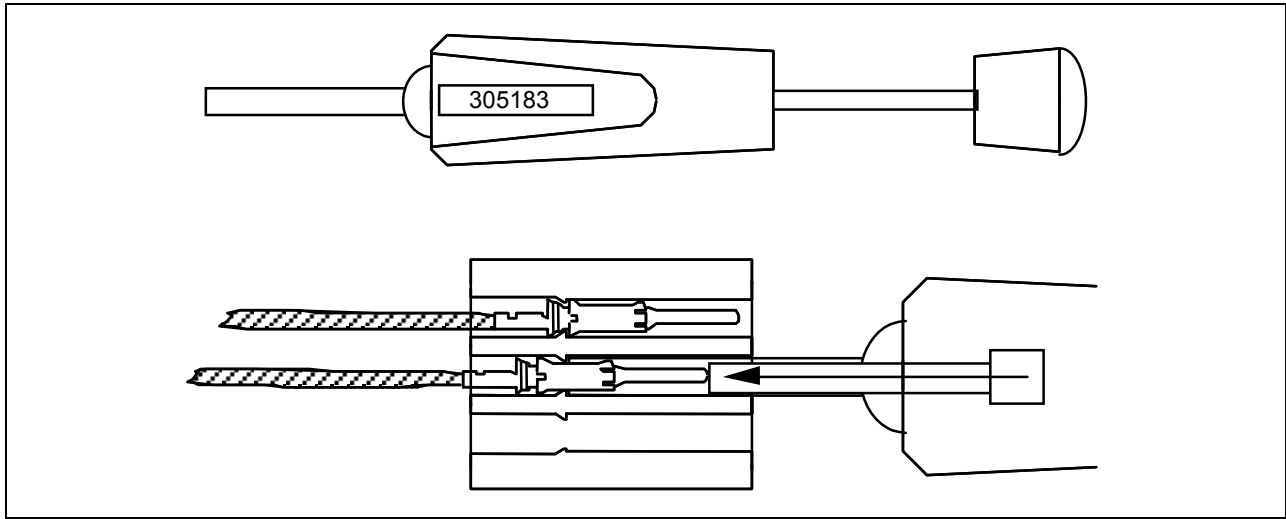

Note: This tool for Alstom terminals P/N 00996-007-ON, P/N 00996-009-ON, P/N 00997-009-ON and P/N 00997-011-ON

Figure 4-3. Extractor, Type M, P/N 59688-005-00

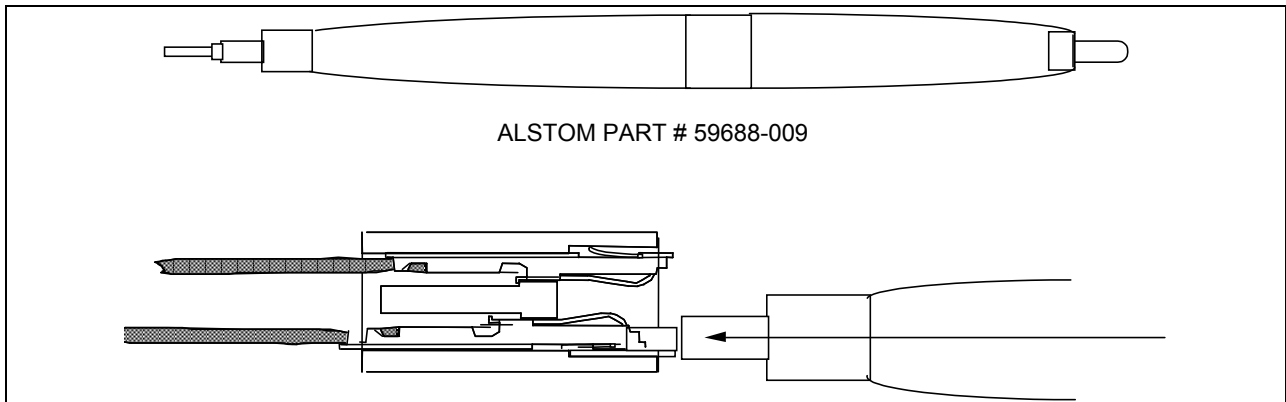

Note: This tool for Alstom terminal P/N 55871-053-00 and P/N 55871-048-00

Figure 4-4. Extractor, Gold Leaf, P/N 59688-009-00

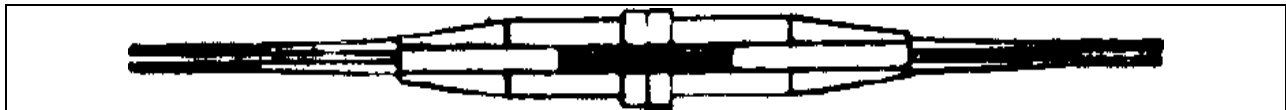

Note: This tool for Alstom terminal P/N 55871-089-00 and P/N 55871-090-00

Figure 4-5. Insertion/Extractor, #24-20, P/N 59688-018-00

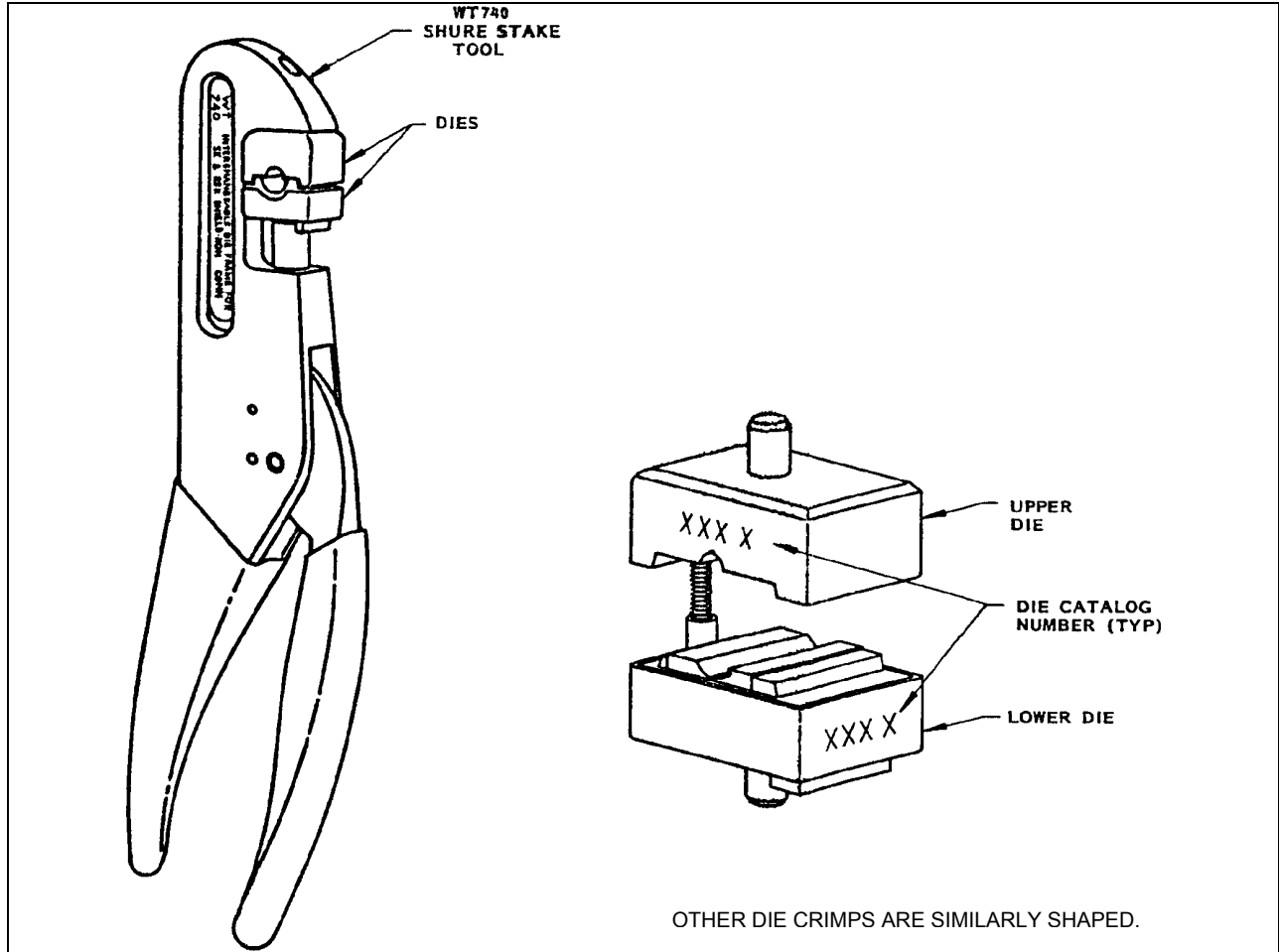

Note: This tool for Alstom terminal P/N 00923-012-ON

Figure 4-6. Thomas and Betts Shield Hand Crimp Tool WT740 with Crimping Die

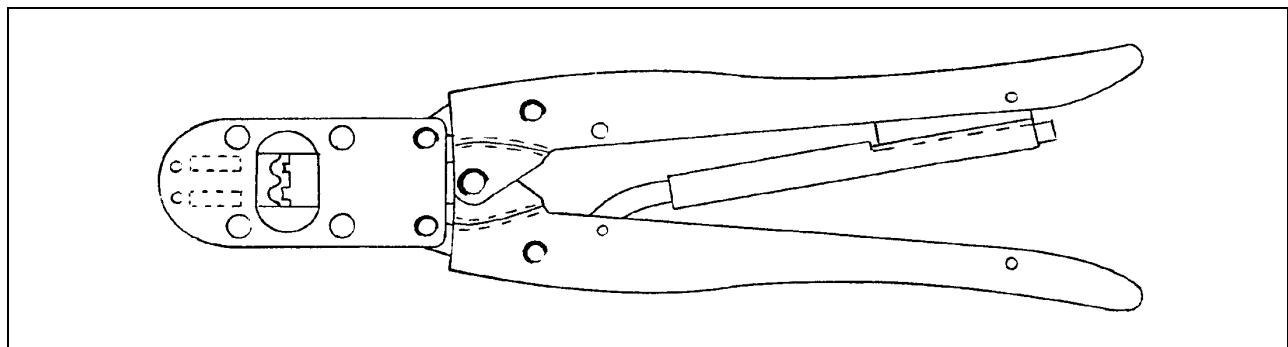

Note: This tool for Alstom terminals P/N 00996-007-ON, P/N 00996-009-ON,  
P/N 00997-009-ON and P/N 00997-011-ON

Figure 4-7. Hand Crimp Tool, Type M #22-20, P/N 24745-048-00

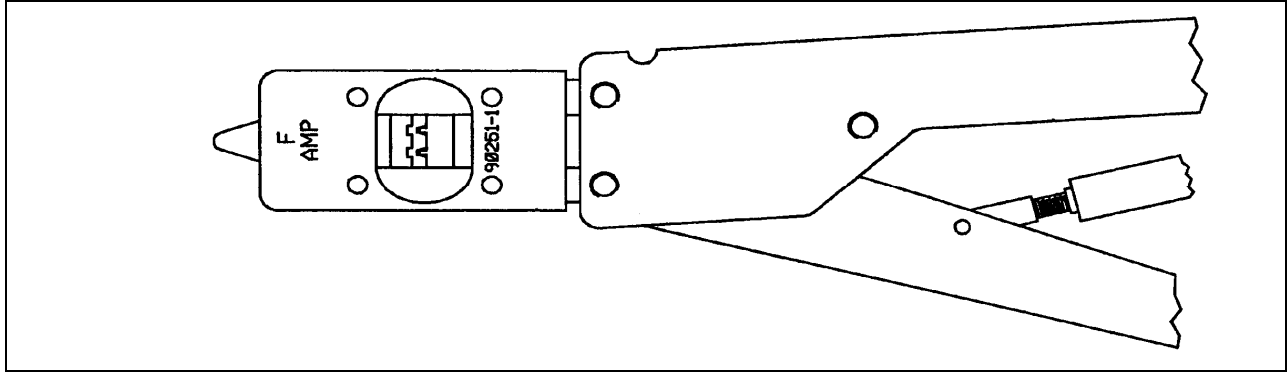

Note: This tool for Alstom terminal P/N 55871-076-00

Figure 4–8. Hand Crimp Tool, P/N 24745-074-00

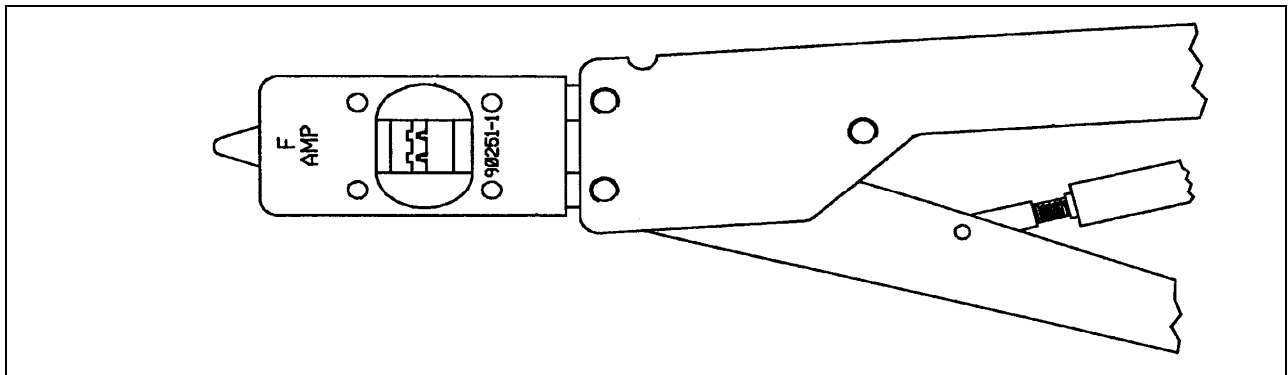

Note 1: This tool for Alstom terminals P/N 55871-089-00 and P/N 55871-090-00

Figure 4–9. Hand Crimp Tool, Type C, P/N 24745-087-00

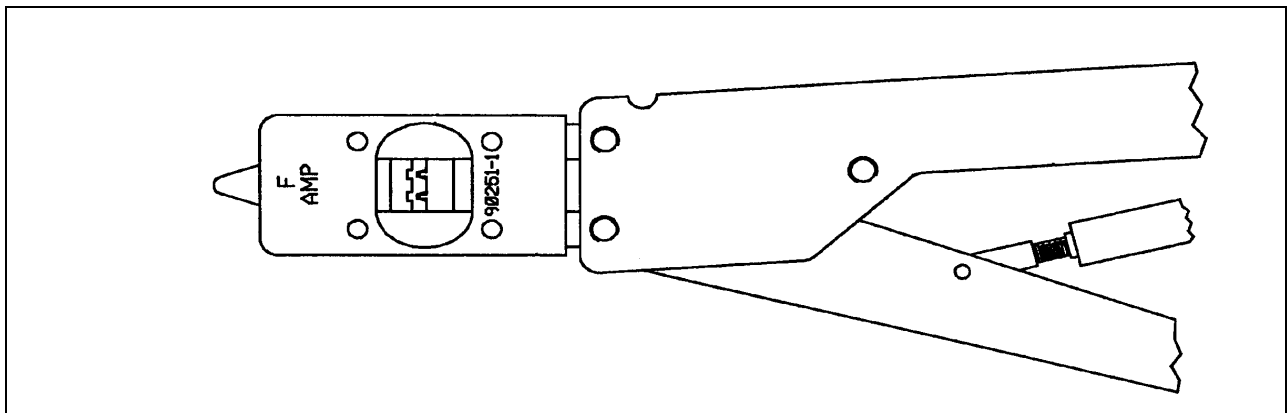

Note: This tool for Alstom terminal P/N 55871-150-00 and P/N 55871-076-00

Figure 4–10. Hand Crimp Tool, Twin Leaf, P/N 24745-126-00

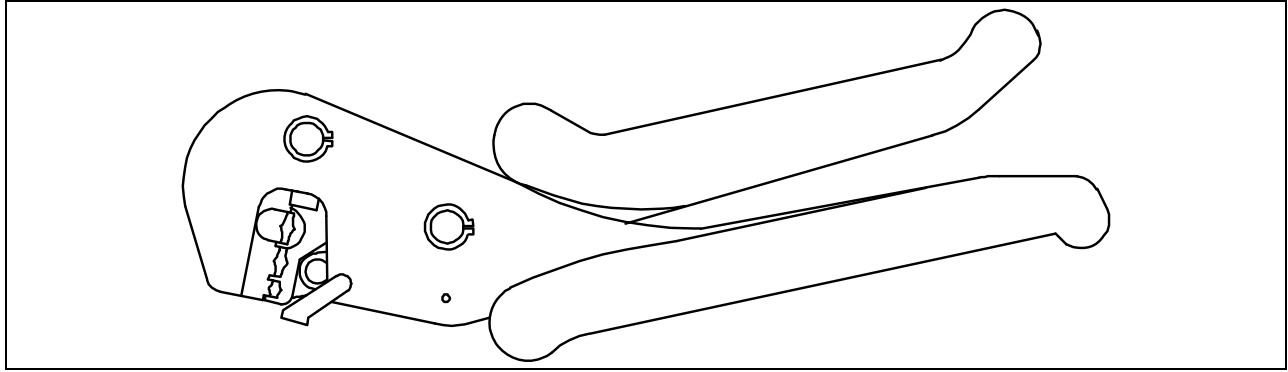

Note: This tool for Alstom terminals P/N 59825-233-00

Figure 4–11. Hand Crimp Tool, Ring #22-16, P/N 24745-145-00

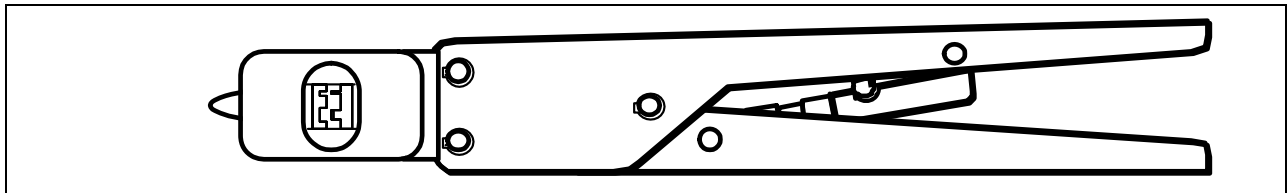

Note: This tool for Alstom terminals P/N 55871-145-00 and P/N 55871-153-00

Figure 4–12. Hand Crimp Tool, P/N 24745-149-00

THIS PAGE INTENTIONALLY LEFT BLANK.



**FOR QUESTIONS AND INQUIRIES, CONTACT CUSTOMER SERVICE AT  
1-800-717-4477  
OR  
[WWW.ALSTOMSIGNALINGSOLUTIONS.COM](http://WWW.ALSTOMSIGNALINGSOLUTIONS.COM)**

**ALSTOM SIGNALING INC.  
1025 JOHN STREET  
WEST HENRIETTA, NY 14586**